

A6E400-AN24-07 ebmpapst Datasheet FansCo

sales@fansco.com

www.fansco.com

## Nominal data

Type	A6E400-AN24-07		
Motor	M6E074-DF		
Phase		1~	1~
Nominal voltage	VAC	230	230
Frequency	Hz	50	60
Type of data definition		ml	ml
Valid for approval / standard		CE	CE
Speed	min <sup>-1</sup>	870	870
Power input	W	120	150
Current draw	A	0.53	0.67
Motor capacitor	µF	3	3
Capacitor voltage	VDB	400	400
Capacitor standard		P0 (CE)	P0 (CE)
Max. back pressure	Pa	40	40
Min. ambient temperature	°C	-25	-25
Max. ambient temperature	°C	60	45
Starting current	A	0.7	0.69

ml = max. load · me = max. efficiency · fa = running at free air · cs = customer specs · cu = customer unit  
 Subject to alterations



## Technical features

<b>Mass</b>	3.3 kg
<b>Size</b>	400 mm
<b>Surface of rotor</b>	Coated in black
<b>Material of blades</b>	PP plastic
<b>Number of blades</b>	5
<b>Direction of air flow</b>	"A"
<b>Direction of rotation</b>	Clockwise, seen on rotor
<b>Type of protection</b>	IP 44; Depending on installation and position as per EN 60034-5
<b>Insulation class</b>	"F"
<b>Humidity class</b>	F1-2
<b>Max. permissible ambient motor temp. (transp./ storage)</b>	+ 80 °C
<b>Min. permissible ambient motor temp. (transp./storage)</b>	- 40 °C
<b>Mounting position</b>	Shaft horizontal or rotor on top; rotor on bottom on request
<b>Condensate discharge holes</b>	On the stator side
<b>Operation mode</b>	S1
<b>Motor bearing</b>	Ball bearing
<b>Touch current acc. IEC 60990 (measuring network Fig. 4, TN system)</b>	< 0.75 mA
<b>Motor protection</b>	Thermal overload protector (TOP) wired internally
<b>Cable exit</b>	Variable
<b>Protection class</b>	I (if protective earth is connected by customer)
<b>Product conforming to standard</b>	EN 60335-1; CE

## Product drawing

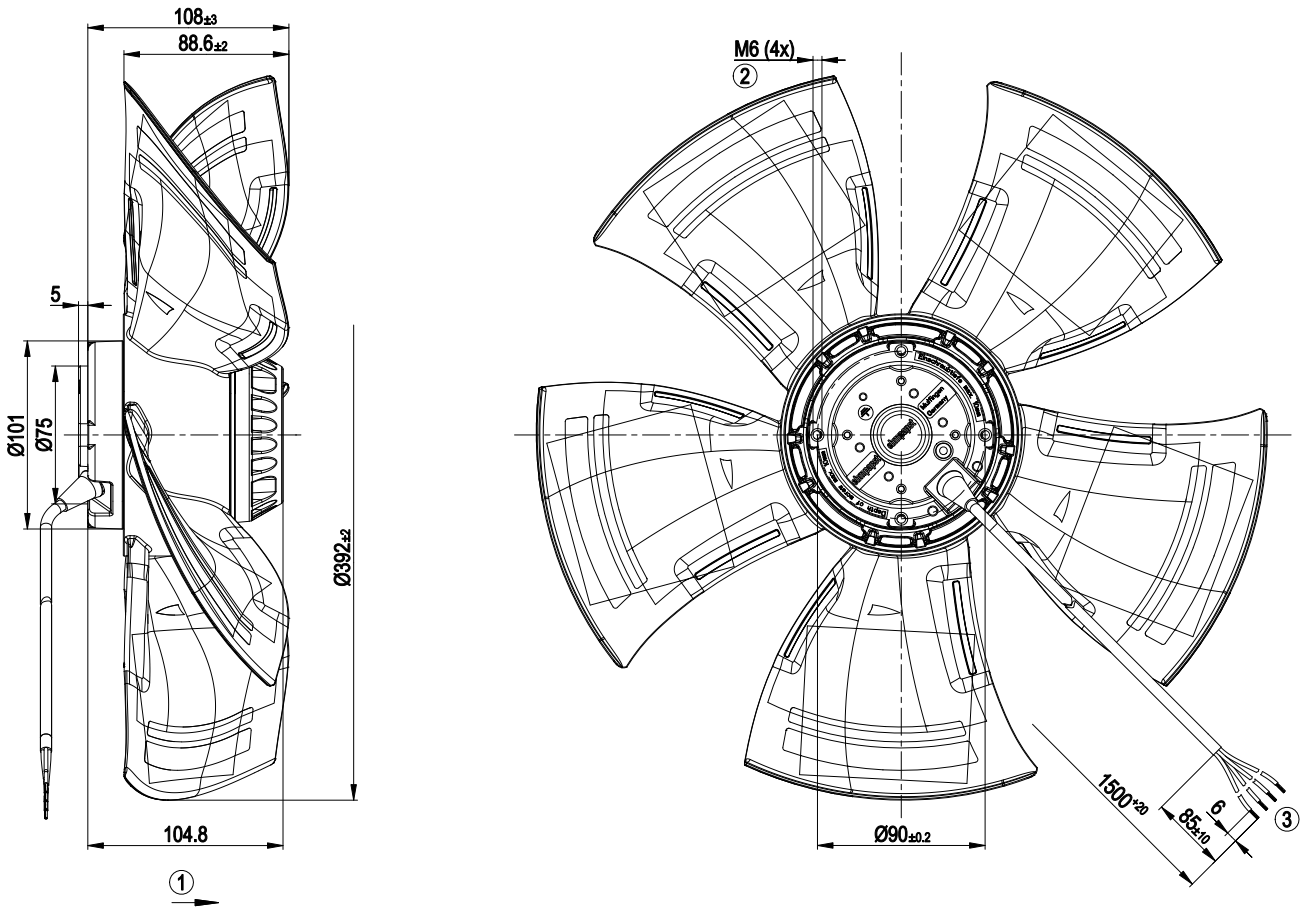

1	Direction of air flow "A"
2	Depth of screw max. 10 mm
3	Connection line silicone 4G 0.5 mm <sup>2</sup> , 4x brass lead tips crimped

## Connection screen

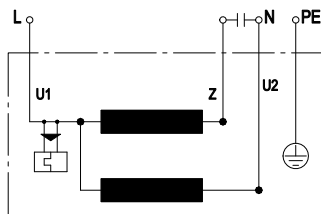

U1	blue	Z	brown	U2	black
PE	green/yellow				

## Charts: Air flow 50 Hz

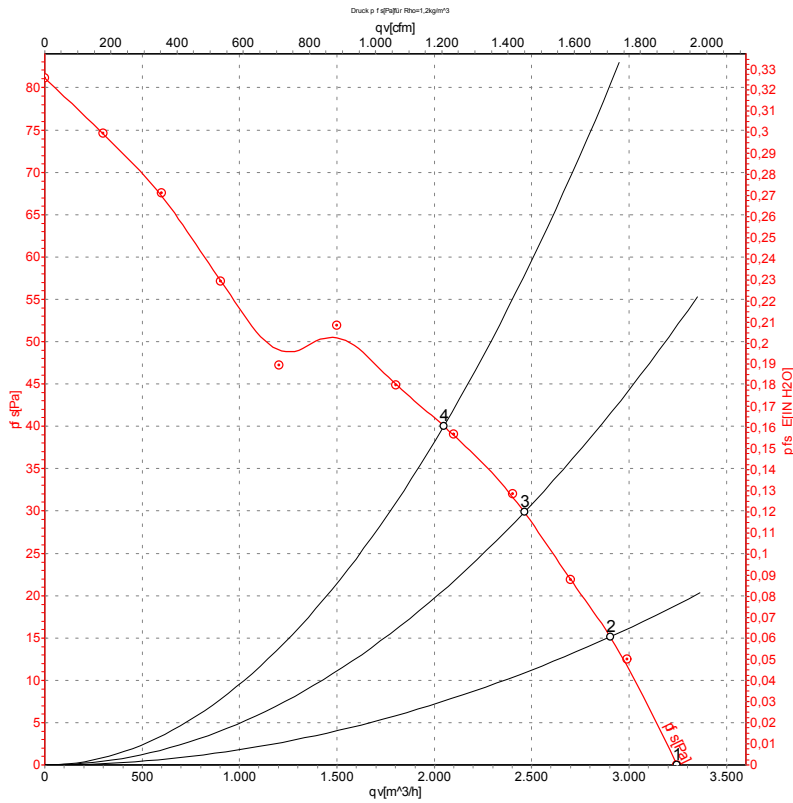

Measurement: LU-126091

Air performance measured as per ISO 5801 Installation category A. For detailed information on the measuring set-up, please contact ebm-papst. Suction-side noise levels: L<sub>wA</sub> measured as per ISO 13347 / L<sub>pA</sub> measured with 1m distance to fan axis. The values given are valid under the measuring conditions mentioned above and may vary according to the actual installation situation. With any deviation from the standard set-up, the specific values have to be checked and reviewed with the unit installed.

## Measured values

	U	f	n	P <sub>e</sub>	I	L <sub>pA<sub>in</sub></sub>	L <sub>wA<sub>in</sub></sub>	qv	p <sub>fs</sub>
	V	Hz	min <sup>-1</sup>	W	A	dB(A)	dB(A)	m <sup>3</sup> /h	Pa
1	230	50	900	110	0.49	57	63	3245	0
2	230	50	900	110	0.49	54	61	2905	15
3	230	50	890	114	0.50	51	58	2460	30
4	230	50	870	120	0.53	52	59	2050	40

U = Supply voltage · f = Frequency · n = Speed · P<sub>e</sub> = Power input · I = Current draw · L<sub>pA<sub>in</sub></sub> = Sound pressure level inlet side · L<sub>wA<sub>in</sub></sub> = Sound power level inlet side · qv = Air flow  
 p<sub>fs</sub> = Pressure increase



## Charts: Air flow 60 Hz

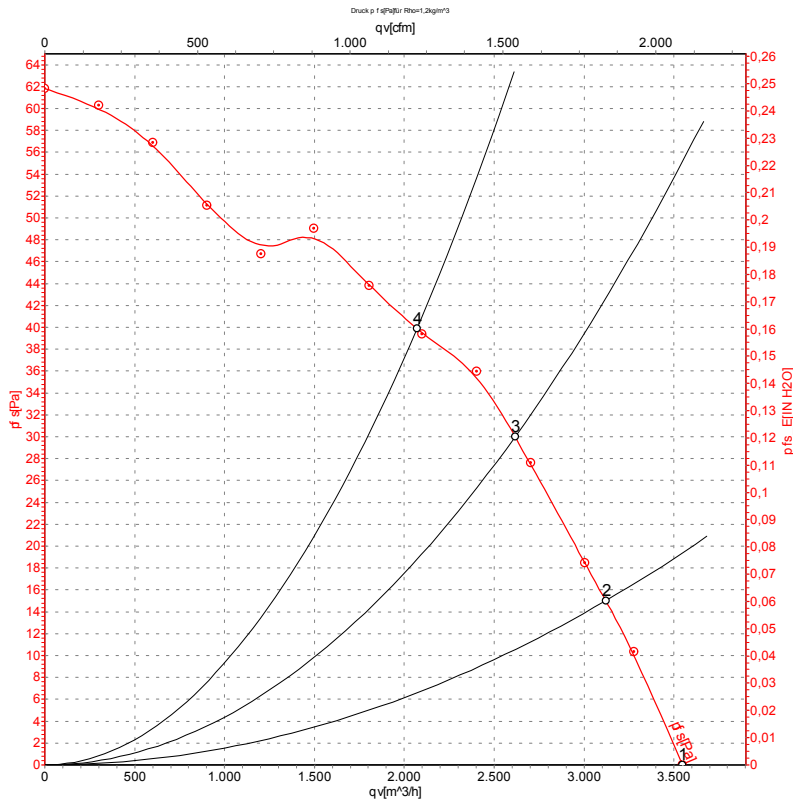

Measurement: LU-126092

Air performance measured as per ISO 5801 Installation category A. For detailed information on the measuring set-up, please contact ebm-papst. Suction-side noise levels: LwA measured as per ISO 13347 / LpA measured with 1m distance to fan axis. The values given are valid under the measuring conditions mentioned above and may vary according to the actual installation situation. With any deviation from the standard set-up, the specific values have to be checked and reviewed with the unit installed.

## Measured values

	U	f	n	P <sub>e</sub>	I	LpA <sub>in</sub>	LwA <sub>in</sub>	qv	p <sub>fs</sub>
	V	Hz	min <sup>-1</sup>	W	A	dB(A)	dB(A)	m <sup>3</sup> /h	Pa
1	230	60	990	145	0.64	59	65	3545	0
2	230	60	955	148	0.64	56	63	3120	15
3	230	60	920	149	0.65	52	59	2615	30
4	230	60	870	150	0.67	52	60	2070	40

U = Supply voltage · f = Frequency · n = Speed · P<sub>e</sub> = Power input · I = Current draw · LpA<sub>in</sub> = Sound pressure level inlet side · LwA<sub>in</sub> = Sound power level inlet side · qv = Air flow  
 p<sub>fs</sub> = Pressure increase

