

A6E360-AA08-05 ebmpapst Datasheet

sales@fansco.com

www.fansco.com

## Nominal data

| Type                        | A6E360-AA08-05    |         |         |
|-----------------------------|-------------------|---------|---------|
| Motor                       | M6E068-DF         |         |         |
| Phase                       |                   | 1~      | 1~      |
| Nominal voltage             | VAC               | 230     | 230     |
| Frequency                   | Hz                | 50      | 60      |
| Method of obtaining data    |                   | fa      | fa      |
| Valid for approval/standard |                   | CE      | CE      |
| Speed (rpm)                 | min <sup>-1</sup> | 850     | 960     |
| Power consumption           | W                 | 65      | 85      |
| Current draw                | A                 | 0.29    | 0.38    |
| Capacitor                   | µF                | 2.5     | 2.5     |
| Capacitor voltage           | VDB               | 400     | 400     |
| Capacitor standard          |                   | S0 (CE) | S0 (CE) |
| Max. back pressure          | Pa                | 50      | 40      |
| Max. back pressure          | in. wg            | 0.2     | 0.16    |
| Min. ambient temperature    | °C                | -25     | -25     |
| Max. ambient temperature    | °C                | 55      | 45      |

ml = Max. load · me = Max. efficiency · fa = Free air · cs = Customer specification · ce = Customer equipment  
Subject to change



### Technical description

|  |  |
|--|--|
| Weight   | 2.2 kg   |
| Size   | 360 mm   |
| Motor size   | 68   |
| Rotor surface  | Painted black  |
| Blade material   | PP plastic   |
| Number of blades   | 4  |
| Airflow direction  | V  |
| Direction of rotation  | Counterclockwise, viewed toward rotor  |
| Degree of protection   | IP44; installation- and position-dependent as per EN 60034-5   |
| Insulation class   | "B"  |
| Moisture (F) / Environmental (H) protection class                          | H1   |
| Max. permitted ambient temp. for motor (transport/storage)                 | +80 °C   |
| Min. permitted ambient temp. for motor (transport/storage)                 | -40 °C   |
| Installation position  | Shaft horizontal or rotor on bottom; rotor on top on request   |
| Condensation drainage holes  | On rotor side  |
| Mode   | S1   |
| Motor bearing  | Ball bearing   |
| Touch current according to IEC 60990 (measuring circuit Fig. 4, TN system) | < 0.75 mA  |
| Motor protection   | Thermal overload protector (TOP) internally connected  |
| With cable   | Axial  |
| Protection class assignment  | I; If a protective earth is connected by the customer<br>This component for installation may have several local protection classes. This information relates to this component's basic design.<br>The final protection class is based on the component's intended installation and connection. |
| Conformity with standards  | EN 60034-1; EN 60204-1; EN 60335-1; CE   |
| Comment on CE  | Ecodesign Directive 2009/125/EC + Fan Directive (EC) No. 327/2011 does not apply, as power consumption <125W.  |
| Approval   | CCC; EAC   |

# AC axial fan

blades with special design (K series)

## Product drawing

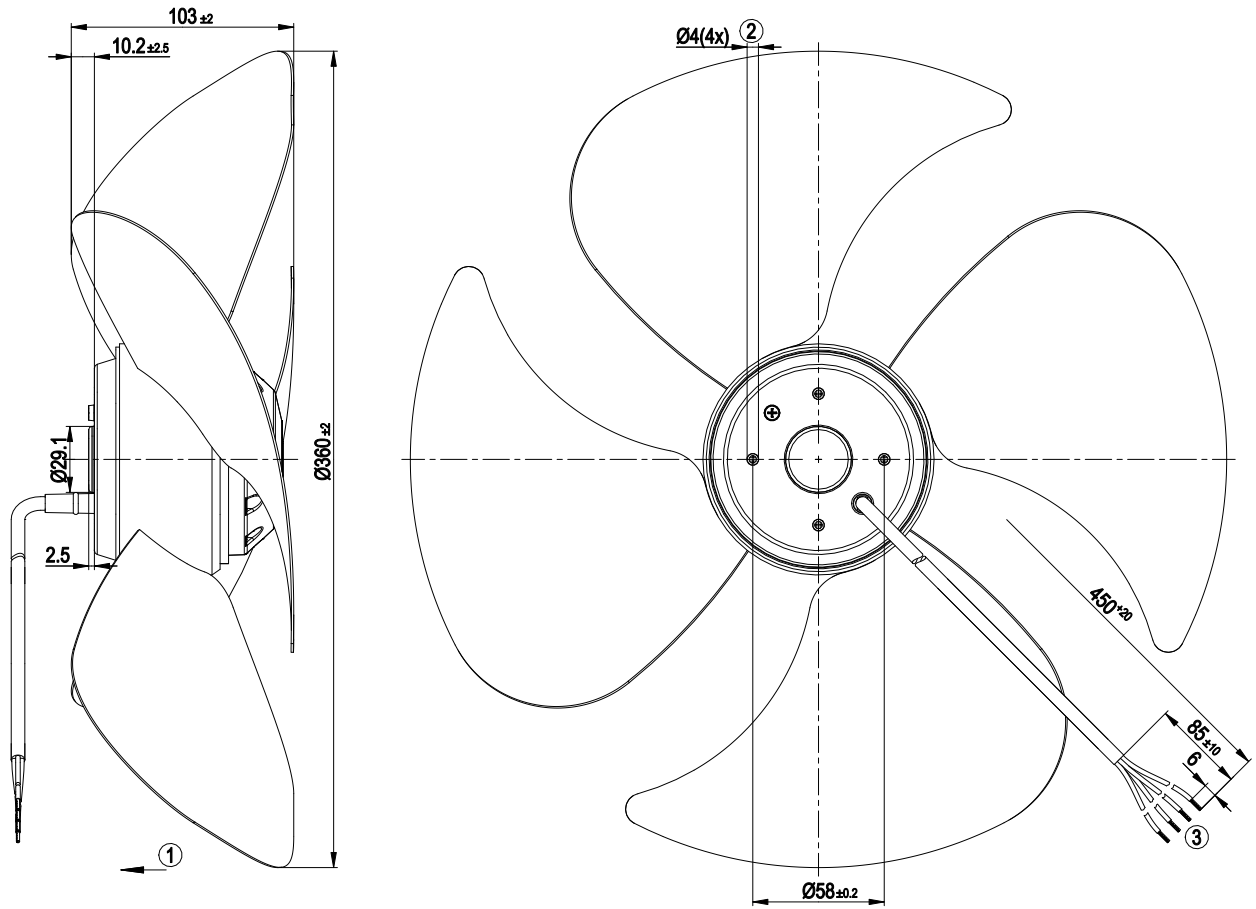

|   |                               |
|---|-------------------------------|
| 1 | Direction of air flow "V"     |
| 2 | Max. clearance for screw 5 mm |
| 3 | Cable PVC AWG20               |
|   | 4x splice                     |



# AC axial fan

blades with special design (K series)

## Connection diagram

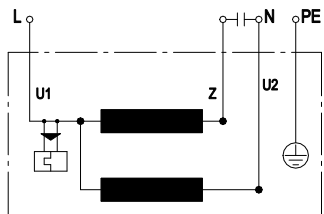

|    |              |   |       |    |       |
|----|--------------|---|-------|----|-------|
| U1 | blue         | Z | brown | U2 | black |
| PE | green/yellow |   |       |    |       |



## Curves: Air performance 50 Hz

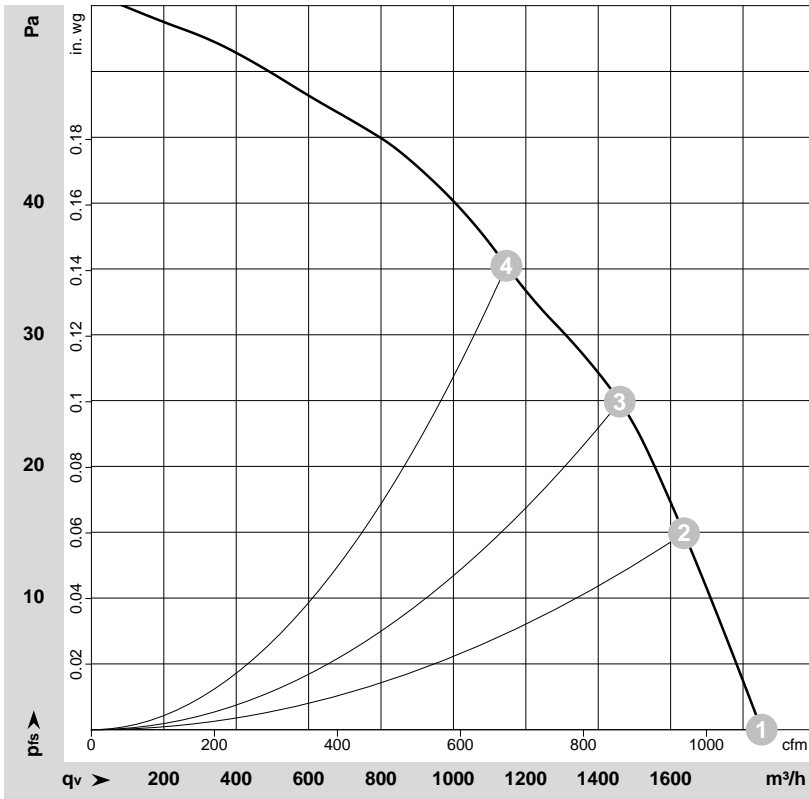

$\rho = 1.15 \text{ kg/m}^3 \pm 2 \%$

Measurement: LU-41796-1

Air performance measured according to ISO 5801 installation category A. For detailed information on the measurement setup, contact ebm-papst. Intake sound level: Sound power level according to ISO 13347 / sound pressure level measured at 1 m distance from fan axis. The values given are valid under the specified measuring conditions and may vary due to conditions of installation. For deviations from the standard configuration, the parameters have to be checked on the installed unit.

## Measured values

|   | Wired | U   | f  | n                 | P <sub>e</sub> | I    | q <sub>v</sub>    | p <sub>fs</sub> | q <sub>v</sub> | p <sub>fs</sub> |
|---|-------|-----|----|-------------------|----------------|------|-------------------|-----------------|----------------|-----------------|
|   |       | V   | Hz | min <sup>-1</sup> | W              | A    | m <sup>3</sup> /h | Pa              | cfm            | in. wg          |
| 1 | 1~    | 230 | 50 | 850               | 65             | 0.29 | 1850              | 0               | 1090           | 0.00            |
| 2 | 1~    | 230 | 50 | 845               | 66             | 0.29 | 1635              | 15              | 965            | 0.06            |
| 3 | 1~    | 230 | 50 | 840               | 66             | 0.29 | 1460              | 25              | 860            | 0.10            |
| 4 | 1~    | 230 | 50 | 810               | 69             | 0.30 | 1145              | 35              | 675            | 0.14            |

Wired = Wiring · U = Voltage · f = Frequency · n = Speed (rpm) · P<sub>e</sub> = Power consumption · I = Current draw · q<sub>v</sub> = Air flow · p<sub>fs</sub> = Pressure increase



## Curves: Air performance 60 Hz

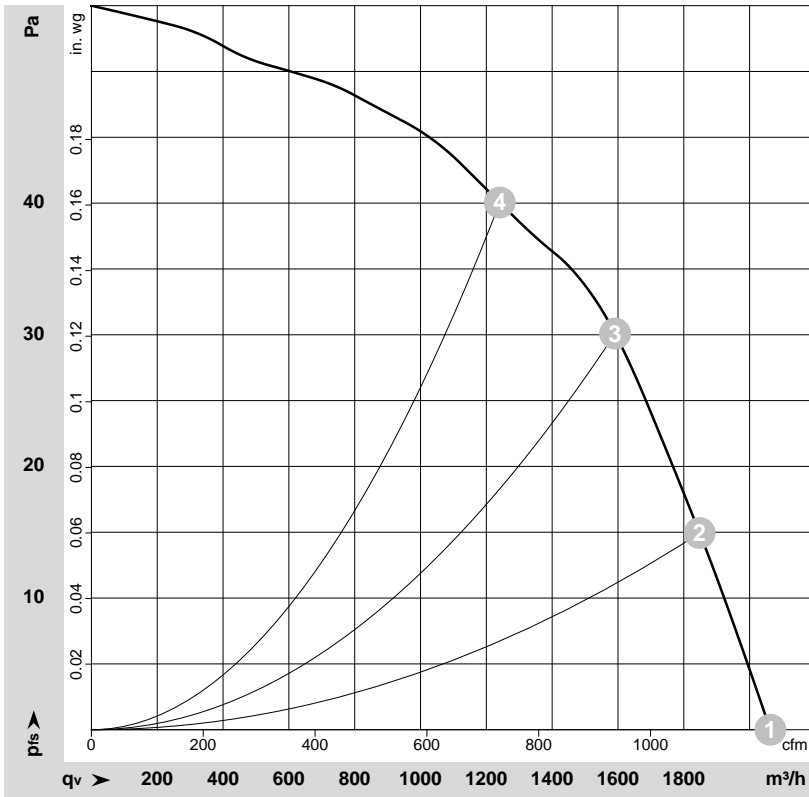

$\rho = 1.15 \text{ kg/m}^3 \pm 2 \%$

Measurement: LU-41797-1

Air performance measured according to ISO 5801 installation category A. For detailed information on the measurement setup, contact ebmpapst. Intake sound level: Sound power level according to ISO 13347 / sound pressure level measured at 1 m distance from fan axis. The values given are valid under the specified measuring conditions and may vary due to conditions of installation. For deviations from the standard configuration, the parameters have to be checked on the installed unit.

## Measured values

|   | Wired | U   | f  | n                 | P <sub>e</sub> | I    | q <sub>v</sub>    | p <sub>fs</sub> | q <sub>v</sub> | p <sub>fs</sub> |
|---|-------|-----|----|-------------------|----------------|------|-------------------|-----------------|----------------|-----------------|
|   |       | V   | Hz | min <sup>-1</sup> | W              | A    | m <sup>3</sup> /h | Pa              | cfm            | in. wg          |
| 1 | 1~    | 230 | 60 | 960               | 85             | 0.38 | 2065              | 0               | 1215           | 0.00            |
| 2 | 1~    | 230 | 60 | 935               | 87             | 0.38 | 1850              | 15              | 1090           | 0.06            |
| 3 | 1~    | 230 | 60 | 920               | 87             | 0.39 | 1590              | 30              | 935            | 0.12            |
| 4 | 1~    | 230 | 60 | 865               | 89             | 0.39 | 1240              | 40              | 730            | 0.16            |

Wired = Wiring · U = Voltage · f = Frequency · n = Speed (rpm) · P<sub>e</sub> = Power consumption · I = Current draw · q<sub>v</sub> = Air flow · p<sub>fs</sub> = Pressure increase

