

A6E315-AS02-11 ebmpapst Datasheet

sales@fansco.com

www.fansco.com

Limited partnership · Headquarters Muldingen
County court Stuttgart · HRA 590344

General partner Elektrobau Muldingen GmbH · Headquarters Muldingen
County court Stuttgart · HRB 590142

Nominal data

Type	A6E315-AS02-11		
Motor	M6E068-DF		
Phase		1~	1~
Nominal voltage	VAC	230	230
Frequency	Hz	50	60
Type of data definition		ml	ml
Valid for approval / standard		CE	CE
Speed (rpm)	min ⁻¹	920	1080
Power input	W	65	75
Current draw	A	0.33	0.33
Motor capacitor	µF	2	2
Capacitor voltage	VDB	400	400
Capacitor standard		S0 (CE)	S0 (CE)
Max. back pressure	Pa	30	40
Min. ambient temperature	°C	-25	-25
Max. ambient temperature	°C	50	70

ml = Max. load · me = Max. efficiency · fa = Running at free air · cs = Customer specs · cu = Customer unit
Subject to alterations



AC axial fan

sickled blades (S series), single inlet

Technical features

Mass	2.0 kg
Size	315 mm
Surface of rotor	Coated in black
Material of blades	Press-fitted sheet steel blank, sprayed with PP plastic
Number of blades	5
Direction of air flow	"A"
Direction of rotation	Clockwise, seen on rotor
Type of protection	IP 44; Depending on installation and position as per EN 60034-5
Insulation class	"F"
Humidity (F)/environmental protection class (H)	H0+
Max. permissible ambient motor temp. (transp./ storage)	+ 80 °C
Min. permissible ambient motor temp. (transp./storage)	- 40 °C
Mounting position	Shaft horizontal or rotor on bottom; rotor on top on request
Condensate discharge holes	Rotor-side
Operation mode	S1
Motor bearing	Ball bearing
Touch current acc. IEC 60990 (measuring network Fig. 4, TN system)	< 0.75 mA
Motor protection	Thermal overload protector (TOP) brought out, basic insulation
Cable exit	Axial
Protection class	I (if protective earth is connected by customer)
Product conforming to standard	EN 60335-1; CE



AC axial fan

sickled blades (S series), single inlet

Product drawing

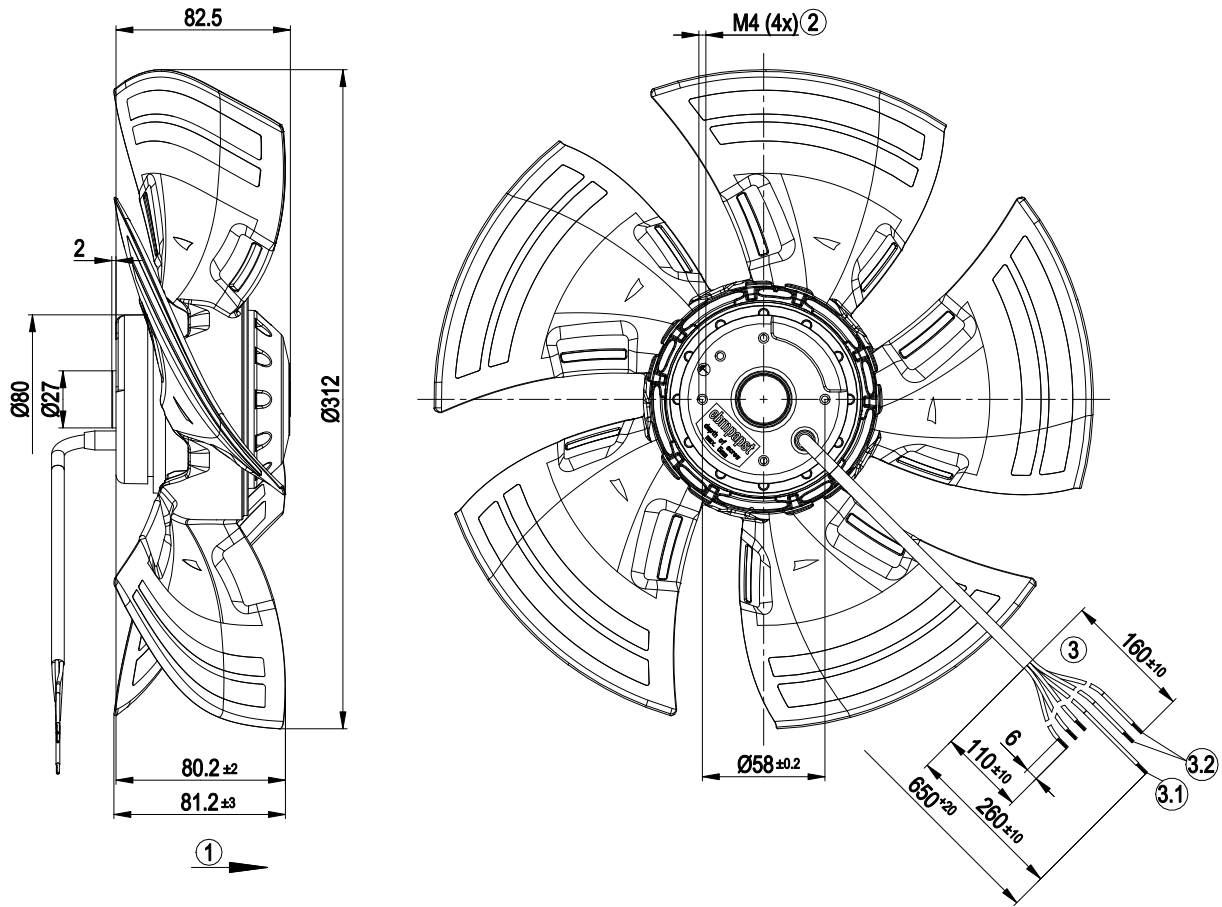

1	Direction of air flow "A"
2	Thread reach max. 5 mm
3	Connection line silicone 6G 0.5 mm ² , 6x lead tips crimped
3.1	PE (green/yellow)
3.2	TOP (grey)



AC axial fan

sickled blades (S series), single inlet

Connection screen

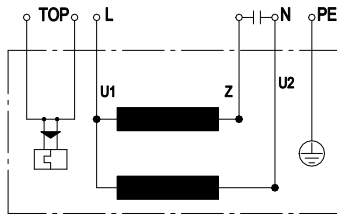

U1	Blue	Z	brown	U2	black
PE	green/yellow	TOP	2 x grey		



Charts: Air flow 50 Hz

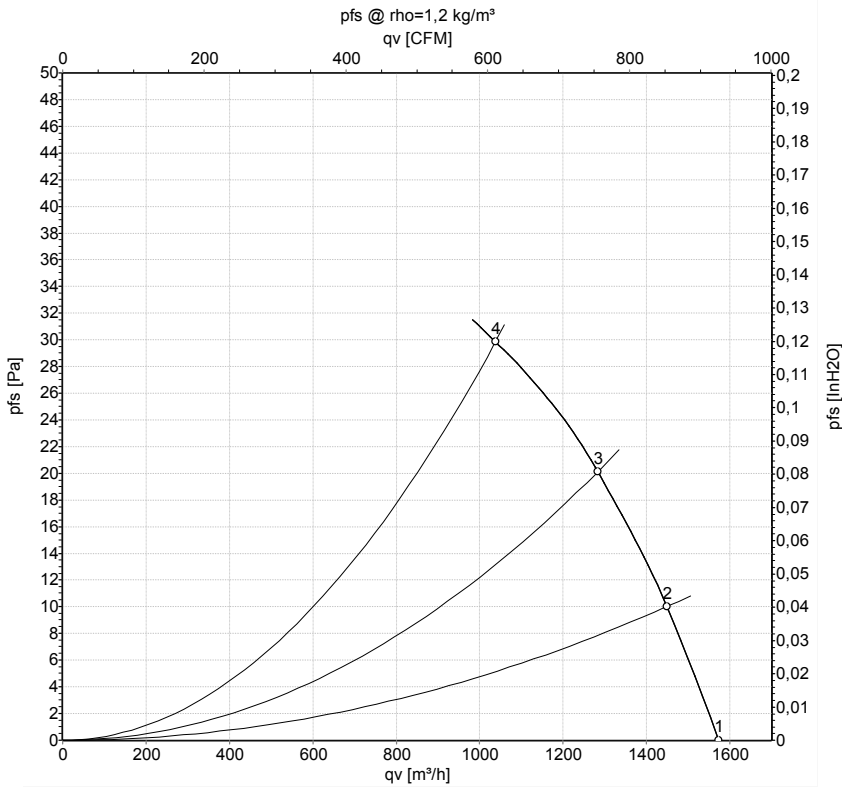

Measurement: LU-162401-1

Air performance measured as per ISO 5801 Installation category A. For detailed information on the measuring set-up, please contact ebm-papst. Suction-side noise levels: LwA measured as per ISO 13347 / LpA measured with 1m distance to fan axis. The values given are valid under the measuring conditions mentioned above and may vary according to the actual installation situation. With any deviation from the standard set-up, the specific values have to be checked and reviewed with the unit installed.

Measured values

	U	f	n	P _e	I	q _v	p _{fs}	q _v	p _{fs}
	V	Hz	min ⁻¹	W	A	m³/h	Pa	cfm	inH2O
1	230	50	940	60	0.32	1575	0	925	0.00
2	230	50	935	61	0.32	1450	10	855	0.04
3	230	50	930	62	0.32	1285	20	755	0.08
4	230	50	920	65	0.33	1040	30	610	0.12

U = Supply voltage · f = Frequency · n = Speed (rpm) · P_e = Power input · I = Current draw · q_v = Air flow · p_{fs} = Pressure increase



Charts: Air flow 60 Hz

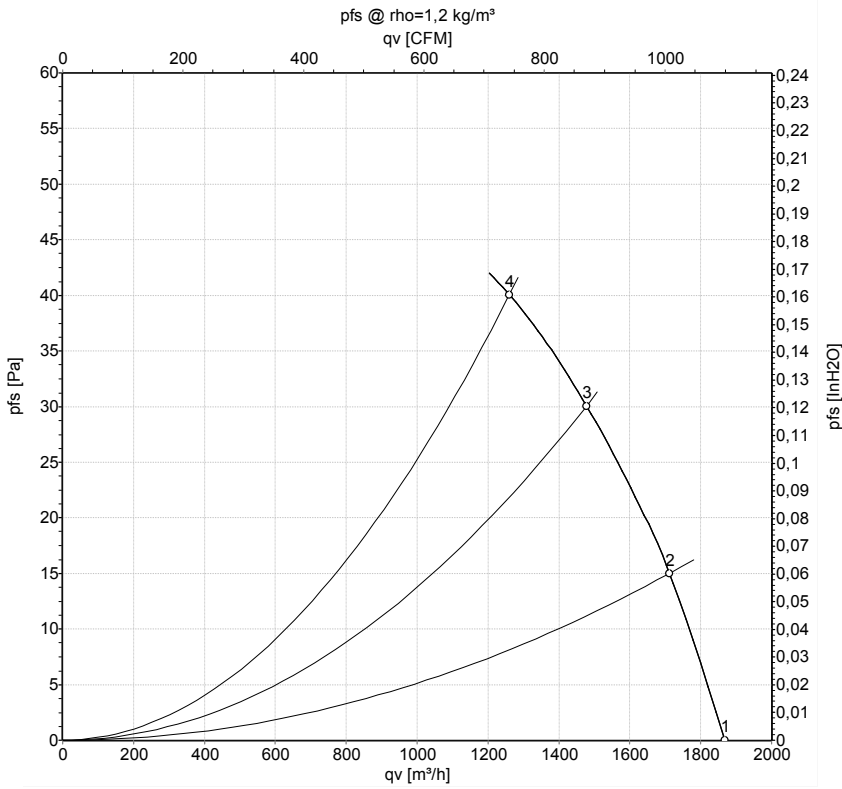

Measurement: LU-160721-1

Air performance measured as per ISO 5801 Installation category A. For detailed information on the measuring set-up, please contact ebm-papst. Suction-side noise levels: LwA measured as per ISO 13347 / LpA measured with 1m distance to fan axis. The values given are valid under the measuring conditions mentioned above and may vary according to the actual installation situation. With any deviation from the standard set-up, the specific values have to be checked and reviewed with the unit installed.

Measured values

	U	f	n	P _e	I	q _v	p _{fs}	q _v	p _{fs}
	V	Hz	min ⁻¹	W	A	m³/h	Pa	cfm	inH2O
1	230	60	1110	67	0.30	1870	0	1100	0.00
2	230	60	1105	69	0.30	1710	15	1010	0.06
3	230	60	1090	70	0.31	1480	30	870	0.12
4	230	60	1080	75	0.33	1260	40	740	0.16

U = Supply voltage · f = Frequency · n = Speed (rpm) · P_e = Power input · I = Current draw · q_v = Air flow · p_{fs} = Pressure increase

