

A6D990-AX05-85 ebmpapst Datasheet

sales@fansco.com

www.fansco.com

Limited partnership · Headquarters Muldingen
County court Stuttgart · HRA 590344

General partner Elektrobau Muldingen GmbH · Headquarters Muldingen
County court Stuttgart · HRB 590142

Nominal data

Type	A6D990-AX05-85		
Motor	M6D138-OA		
Phase		3~	3~
Nominal voltage	VAC	380	380
Connection		Δ	Y
Frequency	Hz	50	50
Type of data definition		ml	ml
Valid for approval / standard		CE	CE
Speed (rpm)	min ⁻¹	920	750
Power input	W	2390	1720
Current draw	A	5.32	3.3
Max. back pressure	Pa	117	77
Min. ambient temperature	°C	-40	-40
Max. ambient temperature	°C	60	60

ml = Max. load · me = Max. efficiency · fa = Running at free air · cs = Customer specs · cu = Customer unit
Subject to alterations

Data according to ErP directive

		Actual	Request 2015		
01 Overall efficiency η_{es}	%	39.6	36.4	09 Power input P_e	kW 2.69
02 Measurement category		A		09 Air flow q_v	m ³ /h 22620
03 Efficiency category		Static		09 Pressure increase p_{fs}	Pa 170
04 Efficiency grade N		43.2	40	10 Speed (rpm) n	min ⁻¹ 920
05 Variable speed drive		No		11 Specific ratio*	1.00

Data definition with optimum efficiency.
The ErP data is determined using a motor-impeller combination in a standardised measurement configuration.

* Specific ratio = $1 + p_s / 100\,000\text{ Pa}$

LU-134881



Technical features

Mass	29.85 kg
Size	990 mm
Surface of rotor	Cast in aluminium
Material of terminal box	Die-cast aluminium, coated in black
Material of blades	Aluminium sheet insert (coated in black), sprayed with PP plastic
Number of blades	5
Blade angle	-5°
Direction of air flow	"V"
Direction of rotation	Clockwise, seen on rotor
Type of protection	IP 55
Insulation class	"F"
Humidity (F)/environmental protection class (H)	H2+
Max. permissible ambient motor temp. (transp./ storage)	+80 °C
Min. permissible ambient motor temp. (transp./storage)	-40 °C
Mounting position	Any
Condensate discharge holes	None
Operation mode	S1
Motor bearing	Ball bearing
Touch current acc. IEC 60990 (measuring network Fig. 4, TN system)	<= 3.5 mA
Electrical leads	Via terminal box
Motor protection	Thermal overload protector (TOP) brought out, basic insulation
Cable exit	Axial
Protection class	I (if protective earth is connected by customer)
Product conforming to standard	EN 60034-1 (2010); EN 61800-5-1; CE
Approval	VDE; EAC



AC axial fan - HyBlade

sickled blades (S series)

Product drawing

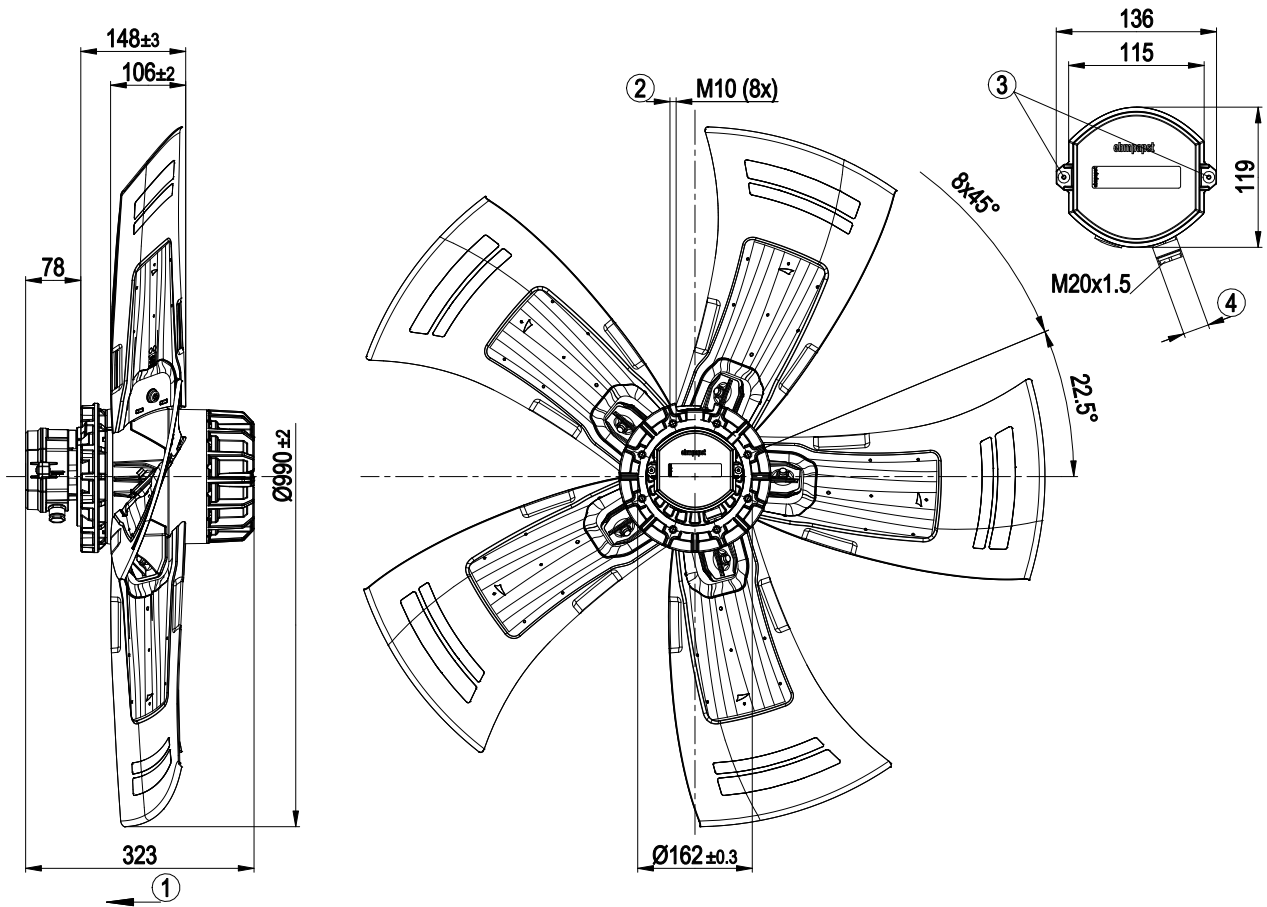

1	Direction of air flow "V"
2	Thread reach max. 18 mm
3	Tightening torque 2.5±0.4 Nm
4	Cable diameter: min. 10 mm, max. 12 mm, tightening torque 4±0.4 Nm



Connection screen

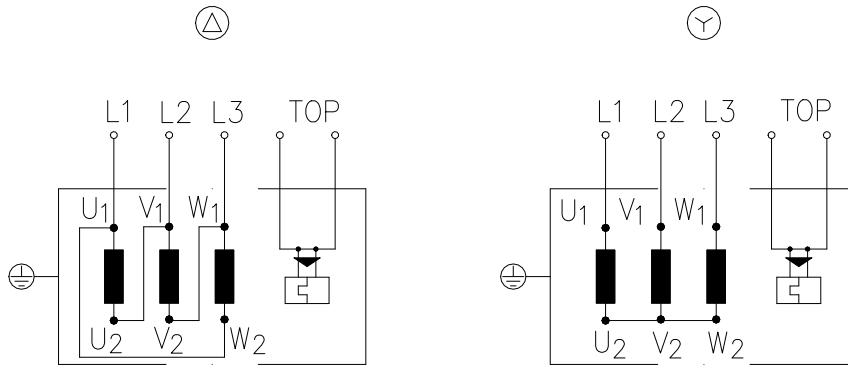

Changing the direction of rotation by reversing the two phases

Δ	Delta connection	Y	Star connection	L1	= U1 = black
L2	= V1 = blue	L3	= W1 = brown	W2	yellow
U2	green	V2	white	TOP	2 x grey
PE	green / yellow				

Charts: Air flow 50 Hz

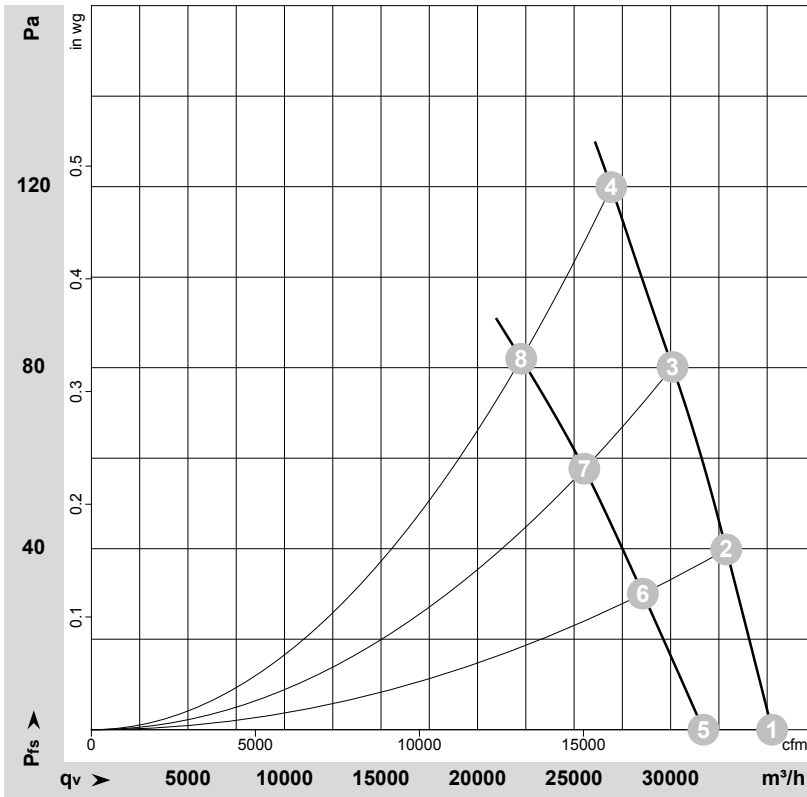

$\rho = 1.15 \text{ kg/m}^3 \pm 2 \%$

Measurement: LU-134881-1
Measurement: LU-134883-1

Air performance measured as per ISO 5801 Installation category A. For detailed information on the measuring set-up, please contact ebmpapst. Suction-side noise levels: LwA measured as per ISO 13347 / LpA measured with 1m distance to fan axis. The values given are valid under the measuring conditions mentioned above and may vary according to the actual installation situation. With any deviation from the standard set-up, the specific values have to be checked and reviewed with the unit installed.

Measured values

	Conn.	U	f	n	P _e	I	LpA _{in}	LwA _{in}	LwA _{out}	q _v	p _{fs}	q _v	p _{fs}
		V	Hz	min ⁻¹	W	A	dB(A)	dB(A)	dB(A)	m ³ /h	Pa	cfm	inH ₂ O
1	Δ	400	50	960	1742	4.92	76	84	84	35260	0	20750	0.00
2	Δ	400	50	950	1996	5.12	75	82	83	32880	40	19355	0.16
3	Δ	400	50	940	2234	5.35	74	81	82	30100	80	17715	0.32
4	Δ	400	50	930	2480	5.63	74	81	81	26925	120	15845	0.48
5	Y	400	50	855	1377	2.60	73	81	81	31700	0	18660	0.00
6	Y	400	50	825	1543	2.90	71	79	79	28565	30	16810	0.12
7	Y	400	50	800	1691	3.18	70	78	77	25530	58	15025	0.23
8	Y	400	50	770	1820	3.42	69	77	76	22265	81	13105	0.33

Conn. = Connection · U = Supply voltage · f = Frequency · n = Speed (rpm) · P_e = Power input · I = Current draw · LpA_{in} = Sound pressure level inlet side · LwA_{in} = Sound power level inlet side
LwA_{out} = Sound power level outlet side · q_v = Air flow · p_{fs} = Pressure increase

