

A6D990-AX01-01 ebmpapst Datasheet FansCo

sales@fansco.com

www.fansco.com

Nominal data

Type	A6D990-AX01-01	
Motor	M6D138-OA	
Phase		3~
Nominal voltage	VAC	400
Connection		Y
Frequency	Hz	50
Type of data definition		ml
Valid for approval / standard		CE
Speed	min ⁻¹	920
Power input	W	2590
Current draw	A	5.5
Max. back pressure	Pa	170
Min. ambient temperature	°C	-40
Max. ambient temperature	°C	55
Starting current	A	20.0

ml = Max. load · me = Max. efficiency · fa = Running at free air · cs = Customer specs · cu = Customer unit
Subject to alterations

Data according to ErP directive

Installation category	A
Efficiency category	Static
Variable speed drive	No
Specific ratio*	1.00

* Specific ratio = $1 + p_{fs} / 100\,000\text{ Pa}$

		Actual	Request 2013	Request 2015
Overall efficiency η_{es}	%	39.8	32.2	36.2
Efficiency grade N		43.6	36	40
Power input P_e	kW	2.56		
Air flow q_v	m ³ /h	22085		
Pressure increase p_{fs}	Pa	167		
Speed n	min ⁻¹	920		

Data definition with optimum efficiency.
The ErP data is determined using a motor-impeller combination in a standardised measurement configuration.



Technical features

Mass	31.6 kg
Size	990 mm
Surface of rotor	Cast in aluminium
Material of terminal box	ABS plastic
Material of blades	Aluminium sheet insert, sprayed with PP plastic
Number of blades	5
Blade angle	-5°
Direction of air flow	"V"
Direction of rotation	Clockwise, seen on rotor
Type of protection	IP 54
Insulation class	"F"
Humidity class	F3-1
Max. permissible ambient motor temp. (transp./ storage)	+80 °C
Min. permissible ambient motor temp. (transp./storage)	-40 °C
Mounting position	Shaft horizontal or rotor on bottom; rotor on top on request
Condensate discharge holes	Rotor-side
Operation mode	S1
Motor bearing	Ball bearing
Touch current acc. IEC 60990 (measuring network Fig. 4, TN system)	<= 3.5 mA
Electrical leads	Via terminal box
Motor protection	Thermal overload protector (TOP) brought out
Cable exit	Axial
Protection class	I (if protective earth is connected by customer)
Product conforming to standard	EN 60034; EN 61800-5-1; CE
Approval	VDE

Product drawing

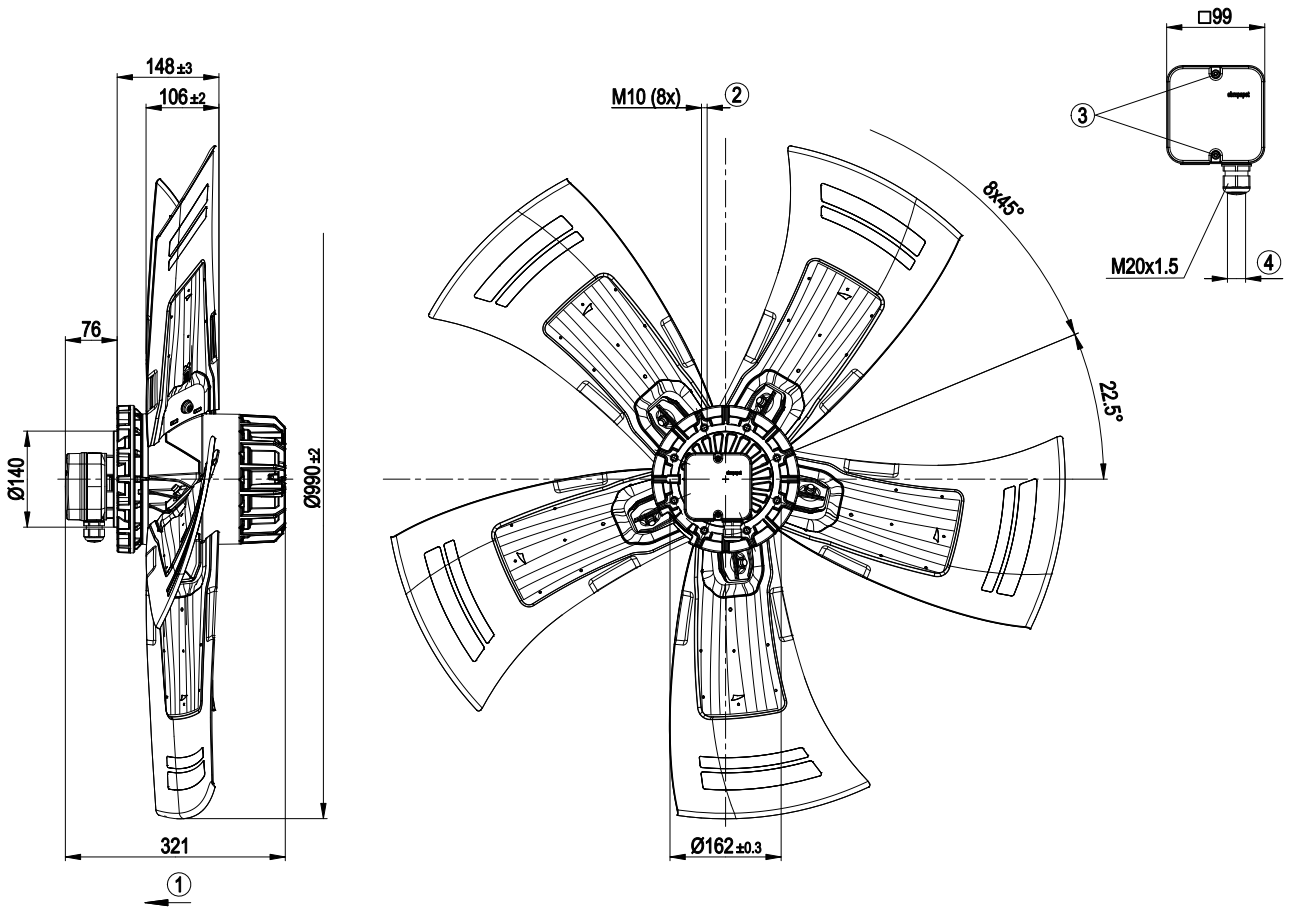

1	Direction of airflow "V"
2	Depth of screw max. 18 mm
3	Tightening torque 1.5±0.2 Nm
4	Cable diameter min. 7 mm, max. 14 mm, tightening torque 2±0.3 Nm



Connection screen

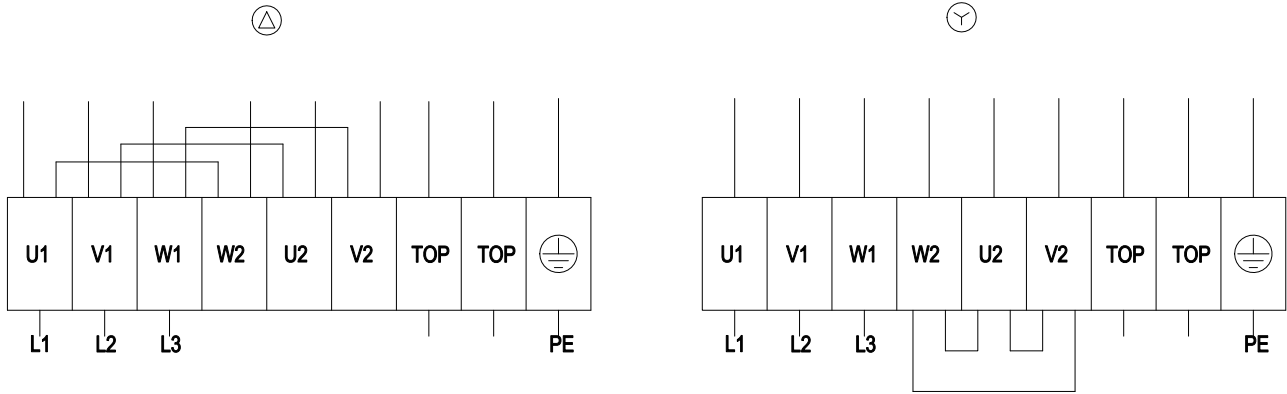

Δ	Delta connection	Y	Star connection	L1	= U1 = black
L2	= V1 = blue	L3	= W1 = brown	W2	yellow
U2	green	V2	white	TOP	2 x grey
PE	green/yellow				



Charts: Air flow 50 Hz

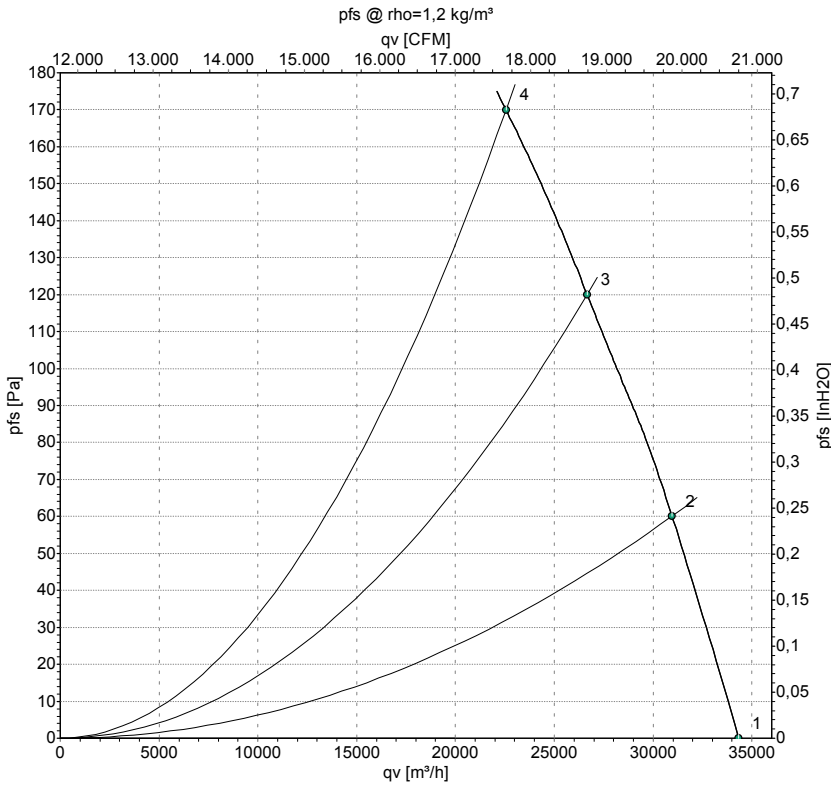

Measurement: LU-114362

Air performance measured as per ISO 5801 Installation category A. For detailed information on the measuring set-up, please contact ebm-papst. Suction-side noise levels: L_{wA} measured as per ISO 13347 / L_{pA} measured with 1m distance to fan axis. The values given are valid under the measuring conditions mentioned above and may vary according to the actual installation situation. With any deviation from the standard set-up, the specific values have to be checked and reviewed with the unit installed.

Measured values

	Conn.	U	f	n	P_e	I	$L_{pA_{in}}$	$L_{wA_{in}}$	$L_{wA_{out}}$	qv	p_{fs}
		V	Hz	min^{-1}	W	A	dB(A)	dB(A)	dB(A)	$\text{m}^3\text{/h}$	Pa
1	Y	400	50	955	1684	4.40	76	83	84	34340	0
2	Y	400	50	940	2023	4.76	75	82	83	30955	60
3	Y	400	50	930	2335	5.16	75	82	82	26665	120
4	Y	400	50	920	2590	5.50	77	84	85	22560	170

Conn. = Connection · U = Supply voltage · f = Frequency · n = Speed · P_e = Power input · I = Current draw · $L_{pA_{in}}$ = Sound pressure level inlet side · $L_{wA_{in}}$ = Sound power level inlet side
 $L_{wA_{out}}$ = Sound power level outlet side · qv = Air flow · p_{fs} = Pressure increase

