

A6D910-AQ09-06 ebmpapst Datasheet
 sales@fansco.com
 www.fansco.com

Limited partnership · Headquarters Mulfingen
 County court Stuttgart · HRA 590344

General partner Elektrobau Mulfingen GmbH · Headquarters Mulfingen
 County court Stuttgart · HRB 590142



Nominal data

Type	A6D910-AQ09-06		
Motor	M6D138-NA		
Phase		3~	3~
Nominal voltage	VAC	400	400
Connection		Δ	Y
Frequency	Hz	50	50
Type of data definition		ml	ml
Valid for approval / standard		CE	CE
Speed	min ⁻¹	870	630
Power input	W	1800	1060
Current draw	A	3.4	2.0
Max. back pressure	Pa	150	70
Min. ambient temperature	°C	-40	-40
Max. ambient temperature	°C	65	65
Starting current	A	11	3.6

ml = max. load · me = max. efficiency · fa = running at free air · cs = customer specs · cu = customer unit
 Subject to alterations

Data according to ErP directive

Installation category	A	Overall efficiency η_{es}	Actual	Request 2013	Request 2015
Efficiency category	Static	Efficiency grade N	36.6	31.1	35.1
Variable speed drive	No	Power input P_e	41.5	36	40
Specific ratio*	1.00	kW	1.71		
		Air flow q_v	m ³ /h	17585	
		Pressure increase p_{fs}	Pa	129	
		Speed n	min ⁻¹	875	

Data established at point of optimum efficiency

* Specific ratio = $1 + p_{fs} / 100\,000\text{ Pa}$



Technical features

Mass	35 kg
Size	910 mm
Surface of rotor	Cast in aluminium
Material of terminal box	PP plastic
Material of blades	Die-cast aluminium
Number of blades	5
Blade angle	-5°
Direction of air flow	"V"
Direction of rotation	Clockwise, seen on rotor
Type of protection	IP 54
Insulation class	"F"
Humidity class	F3-1
Max. permissible ambient motor temp. (transp./ storage)	+80 °C
Min. permissible ambient motor temp. (transp./storage)	-40 °C
Mounting position	Any
Condensate discharge holes	On rotor and stator sides
Operation mode	S1
Motor bearing	Ball bearing
Touch current acc. IEC 60990 (measuring network Fig. 4, TN system)	<= 3.5 mA
Electrical leads	Via terminal box
Motor protection	Thermal overload protector (TOP) brought out
Cable exit	Axial
Protection class	I (if protective earth is connected by customer)
Product conforming to standard	EN 60034; EN 61800-5-1; CE
Approval	VDE

AC axial fan

sickled blades (S series)

Product drawing

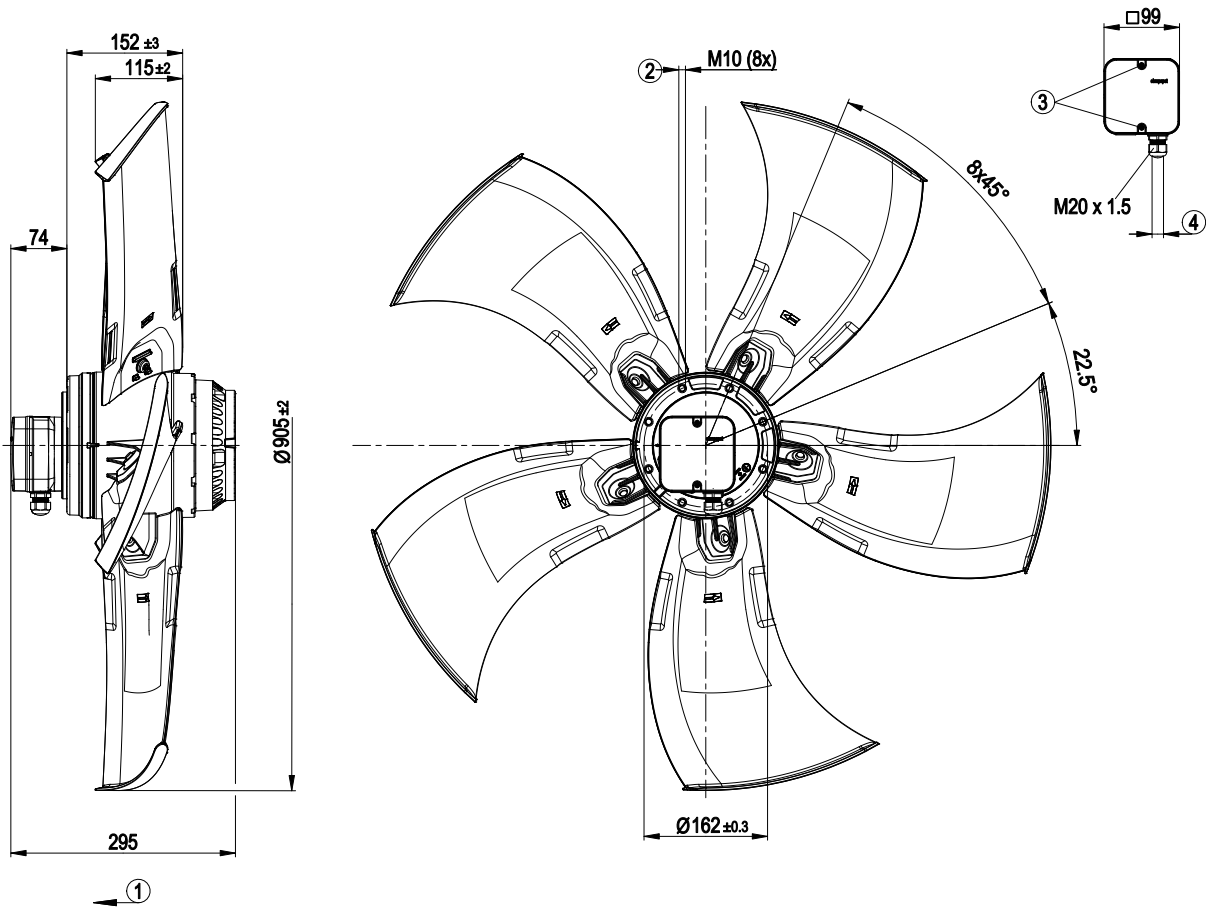

1	Direction of air flow "V"
2	Depth of screw max. 18 mm
3	Tightening torque 1.5±0.2 Nm
4	Cable diameter: min. 7 mm, max. 14 mm; tightening torque: 2±0.3 Nm



Connection screen

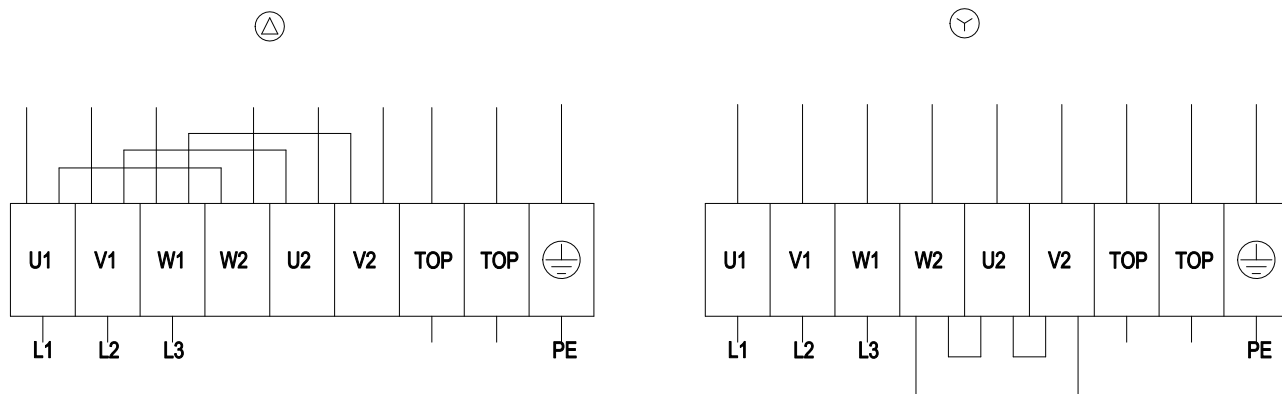

Δ	Delta connection	Y	Star connection	L1	= U1 = black
L2	= V1 = blue	L3	= W1 = brown	W2	yellow
U2	green	V2	white	TOP	2 x grey
PE	green/yellow				

Charts: Air flow 50 Hz

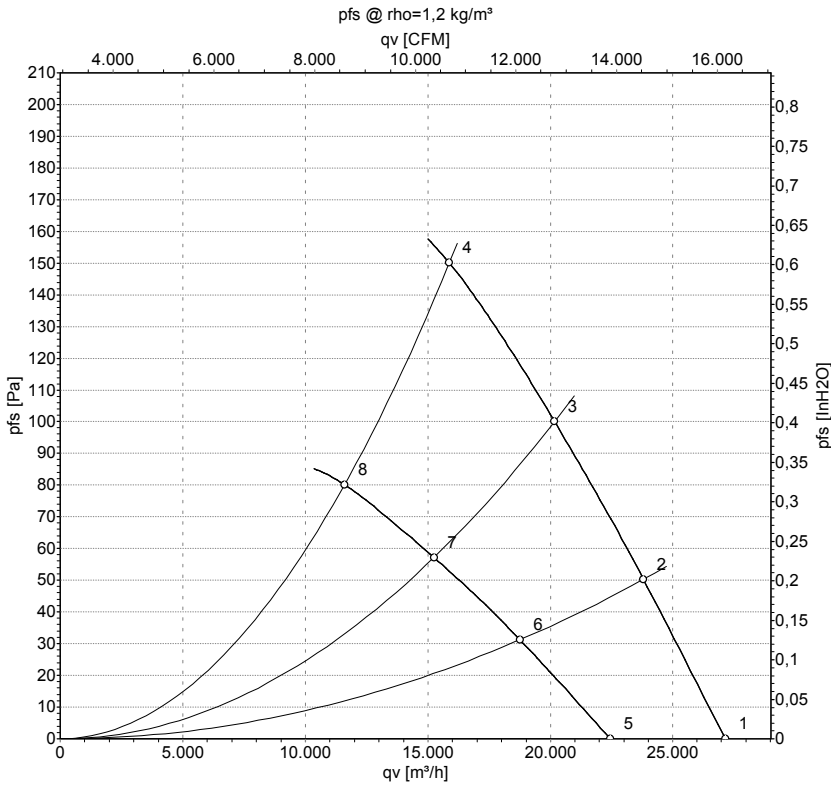

Measurement: LU-108355
Measurement: LU-108371

Air performance measured as per ISO 5801 Installation category A. For detailed information on the measuring set-up, please contact ebm-papst. Suction-side noise levels: LwA measured as per ISO 13347 / LpA measured with 1m distance to fan axis. The values given are valid under the measuring conditions mentioned above and may vary according to the actual installation situation. With any deviation from the standard set-up, the specific values have to be checked and reviewed with the unit installed.

Measured values

	Conn.	U	f	n	P _e	I	LpA _{in}	LwA _{in}	LwA _{out}	qv	p _{fs}
		V	Hz	min ⁻¹	W	A	dB(A)	dB(A)	dB(A)	m ³ /h	Pa
1	Δ	400	50	925	1196	2.54	71	77	76	27135	0
2	Δ	400	50	905	1416	2.84	70	76	74	23800	50
3	Δ	400	50	890	1605	3.11	70	76	74	20175	100
4	Δ	400	50	870	1800	3.40	71	78	77	15875	150
5	Y	400	50	765	861	1.59	66	73	71	22440	0
6	Y	400	50	715	957	1.79	64	71	69	18755	31
7	Y	400	50	675	1020	1.92	63	70	68	15250	57
8	Y	400	50	630	1060	2.00	63	70	68	11600	80

Conn. = Connection · U = Supply voltage · f = Frequency · n = Speed · P_e = Power input · I = Current draw · LpA_{in} = Sound pressure level inlet side · LwA_{in} = Sound power level inlet side · LwA_{out} = Sound power level outlet side · qv = Air flow · p_{fs} = Pressure increase

