

A6D910-AE01-05 ebmpapst Datasheet

sales@fansco.com

www.fansco.com

Nominal data

Type	A6D910-AE01-05		
Motor	M6D138-LA		
Phase		3~	3~
Nominal voltage	VAC	400	400
Connection		Δ	Y
Frequency	Hz	50	50
Type of data definition		ml	ml
Valid for approval / standard		CE	CE
Speed	min ⁻¹	890	670
Power input	W	1840	1150
Current draw	A	3.83	2.22
Max. back pressure	Pa	145	82
Min. ambient temperature	°C	-40	-40
Max. ambient temperature	°C	60	60
Starting current	A	13	4.3

ml = max. load · me = max. efficiency · fa = running at free air · cs = customer specs · cu = customer unit
Subject to alterations

Data according to ErP directive

Installation category	A	Overall efficiency η_{es}	Actual	Request 2013	Request 2015
Efficiency category	Static	Efficiency grade N	37	31.3	35.3
Variable speed drive	No	Power input P_e	41.7	36	40
Specific ratio*	1.00	kW	1.79		
		Air flow q_v	m ³ /h	17950	
		Pressure increase p_{fs}	Pa	134	
		Speed n	min ⁻¹	895	

Data established at point of optimum efficiency



Technical features

Mass	24.9 kg
Size	910 mm
Surface of rotor	Cast in aluminium
Material of terminal box	Plastic, fibreglass reinforced
Material of blades	Aluminium sheet insert, sprayed with PP plastic
Number of blades	5
Blade angle	-5°
Direction of air flow	"A"
Direction of rotation	Counter-clockwise, seen on rotor
Type of protection	IP 54
Insulation class	"F"
Humidity class	F3-1
Max. permissible ambient motor temp. (transp./ storage)	+ 80 °C
Min. permissible ambient motor temp. (transp./storage)	- 40 °C
Mounting position	Any
Condensate discharge holes	On rotor and stator sides
Operation mode	S1
Motor bearing	Ball bearing
Touch current acc. IEC 60990 (measuring network Fig. 4, TN system)	<= 3.5 mA
Electrical leads	Via terminal box
Motor protection	Thermal overload protector (TOP) brought out
Cable exit	Axial
Protection class	I (if protective earth is connected by customer)
Product conforming to standard	EN 60034; EN 61800-5-1; CE
Approval	VDE; CCC

Product drawing

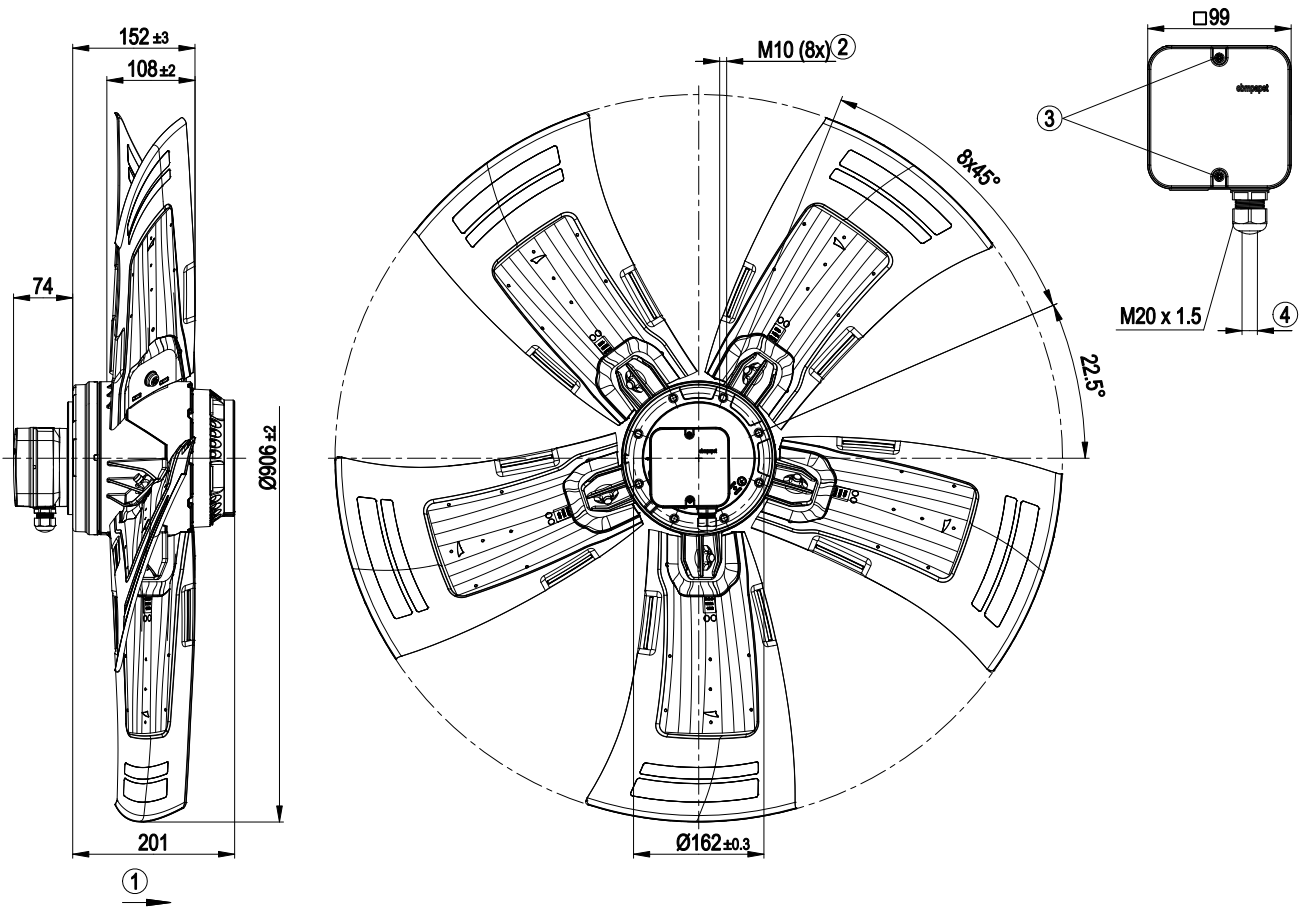

1	Direction of air flow "A"
2	Depth of screw max. 18 mm
3	Tightening torque 1.5 Nm ± 0.2 Nm
4	Cable diameter min. 7 mm, max. 14 mm, tightening torque 2 Nm ± 0.3 Nm

Connection screen

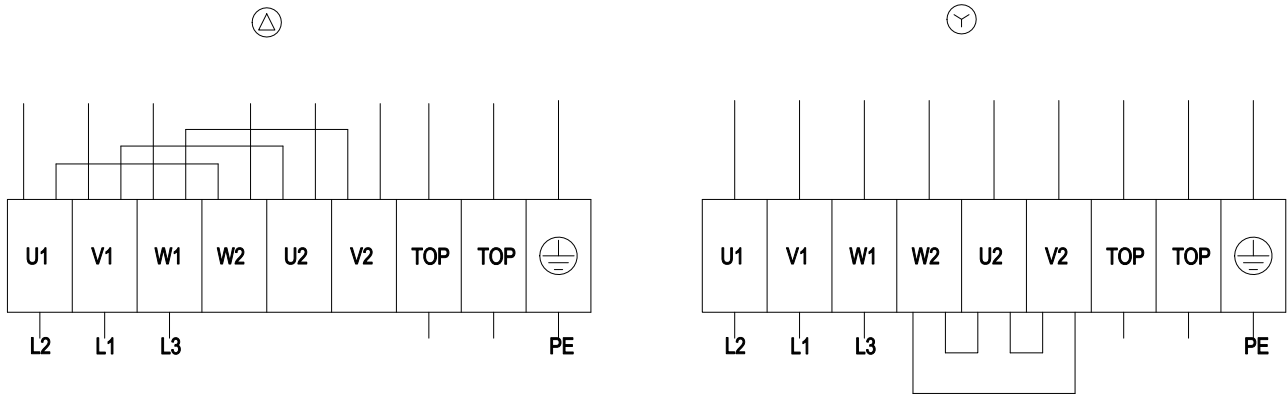

Δ	Delta connection	Y	Star connection	L1	= V1 = blue
L2	= U1 = black	L3	= W1 = brown	W2	yellow
U2	green	V2	white	TOP	2 x grey
PE	green/yellow				

Charts: Air flow 50 Hz

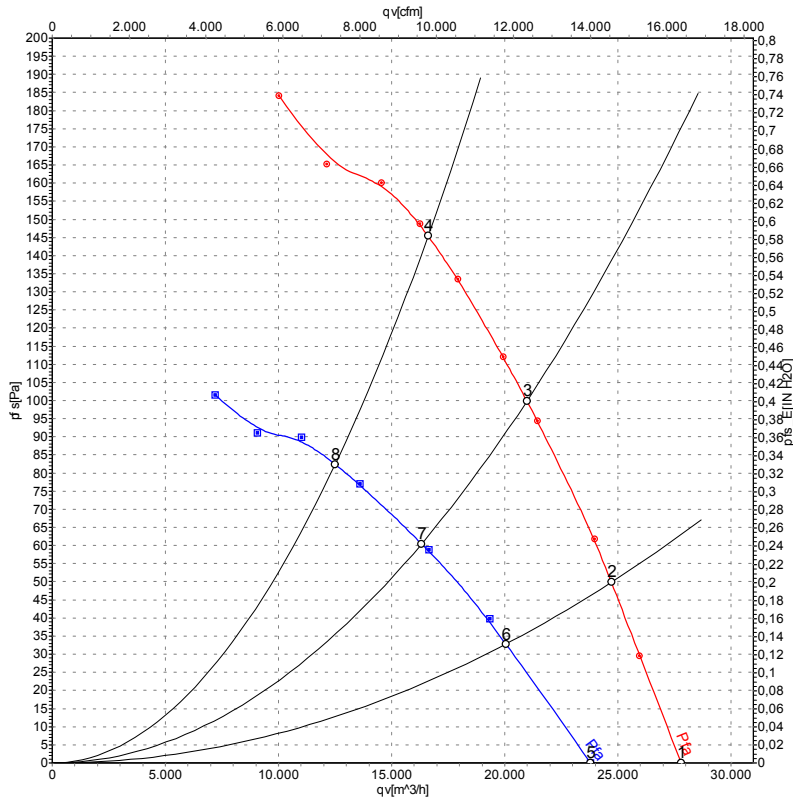

Measurement: LU-120968
Measurement: LU-120972

Air performance measured as per ISO 5801 Installation category A. For detailed information on the measuring set-up, please contact ebm-papst. Suction-side noise levels: LwA measured as per ISO 13347 / LpA measured with 1m distance to fan axis. The values given are valid under the measuring conditions mentioned above and may vary according to the actual installation situation. With any deviation from the standard set-up, the specific values have to be checked and reviewed with the unit installed.

Measured values

	Conn.	U	f	n	P _e	I	LpA _{in}	LwA _{in}	LwA _{out}	qv	p _{fs}
		V	Hz	min ⁻¹	W	A	dB(A)	dB(A)	dB(A)	m ³ /h	Pa
1	Δ	400	50	935	1199	2.99	71	78	78	27800	0
2	Δ	400	50	920	1437	3.26	68	76	76	24720	50
3	Δ	400	50	905	1663	3.57	68	75	75	20990	100
4	Δ	400	50	890	1840	3.83	71	79	78	16620	145
5	Y	400	50	800	882	1.68	67	74	74	23800	0
6	Y	400	50	750	1012	1.93	63	71	70	20050	34
7	Y	400	50	705	1097	2.11	61	69	68	16330	61
8	Y	400	50	670	1150	2.22	66	73	73	12510	82

Conn. = Connection · U = Supply voltage · f = Frequency · n = Speed · P_e = Power input · I = Current draw · LpA_{in} = Sound pressure level inlet side · LwA_{in} = Sound power level inlet side · LwA_{out} = Sound power level outlet side · qv = Air flow · p_{fs} = Pressure increase

