

A6D910-AC05-03 ebmpapst Datasheet FansCo

sales@fansco.com

www.fansco.com

## Nominal data

Type	A6D910-AC05-03				
Motor	M6D138-NA				
Phase		3~	3~	3~	3~
Nominal voltage	VAC	230	277	400	480
Wiring		$\Delta$	$\Delta$	Y	Y
Frequency	Hz	50	60	50	60
Method of obtaining data		ml	ml	ml	ml
Valid for approval/standard		CE	CE	CE	CE
Speed	min <sup>-1</sup>	945	1120	945	1120
Power consumption	W	1480	2410	1480	2410
Current draw	A	7.3	8.25	4.22	4.76
Max. back pressure	Pa	155	220	155	220
Min. ambient temperature	°C	-40	-40	-40	-40
Max. ambient temperature	°C	80	60	80	60
Starting current	A	33	37	19	21.5

ml = Max. load · me = Max. efficiency · fa = Free air · cs = Customer specification · ce = Customer equipment

Subject to change

## Data according to ErP Directive

		Actual	Req. 2015		
01 Overall efficiency $\eta_{es}$	%	41.2	34.7	09 Power consumption $P_e$	kW 1.43
02 Measurement category		A		09 Air flow $q_v$	m <sup>3</sup> /h 15580
03 Efficiency category		Static		09 Pressure increase $p_{fs}$	Pa 137
04 Efficiency grade N		46.5	40	10 Speed n	min <sup>-1</sup> 950
05 Variable speed drive		No		11 Specific ratio*	1.00

Data obtained at optimum efficiency level.

The ErP data is determined using a motor-impeller combination in a standardized measurement setup.

\* Specific ratio =  $1 + p_g / 100\,000\text{ Pa}$ 

LU-118455



## Technical description

Weight	27.8 kg
Fan size	910 mm
Rotor surface	Cast in aluminum
Terminal box material	PC/ABS plastic
Blade material	Sheet aluminum insert, sprayed with PP plastic
Number of blades	5
Blade pitch	-10°
Airflow direction	"V"
Direction of rotation	Clockwise, viewed toward rotor
Degree of protection	IP54
Insulation class	"F"
Moisture (F) / Environmental (H) protection class	F3-1
Max. permitted ambient temp. for motor (transport/storage)	+ 80 °C
Min. permitted ambient temp. for motor (transport/storage)	- 40 °C
Installation position	Any
Condensation drainage holes	On rotor and stator sides
Mode	S1
Motor bearing	Ball bearing
Touch current according to IEC 60990 (measuring circuit Fig. 4, TN system)	<= 3.5 mA
Electrical hookup	Via terminal box
Motor protection	Thermal overload protector (TOP) with basic insulation
With cable	Axial
Protection class	I (with customer connection of protective earth)
Conformity with standards	EN 60034; EN 61800-5-1; CE
Approval	CSA C22.2 No. 100; EAC; UL 1004-1

# AC axial fan - HyBlade

sickle-shaped blades (S series)

## Product drawing

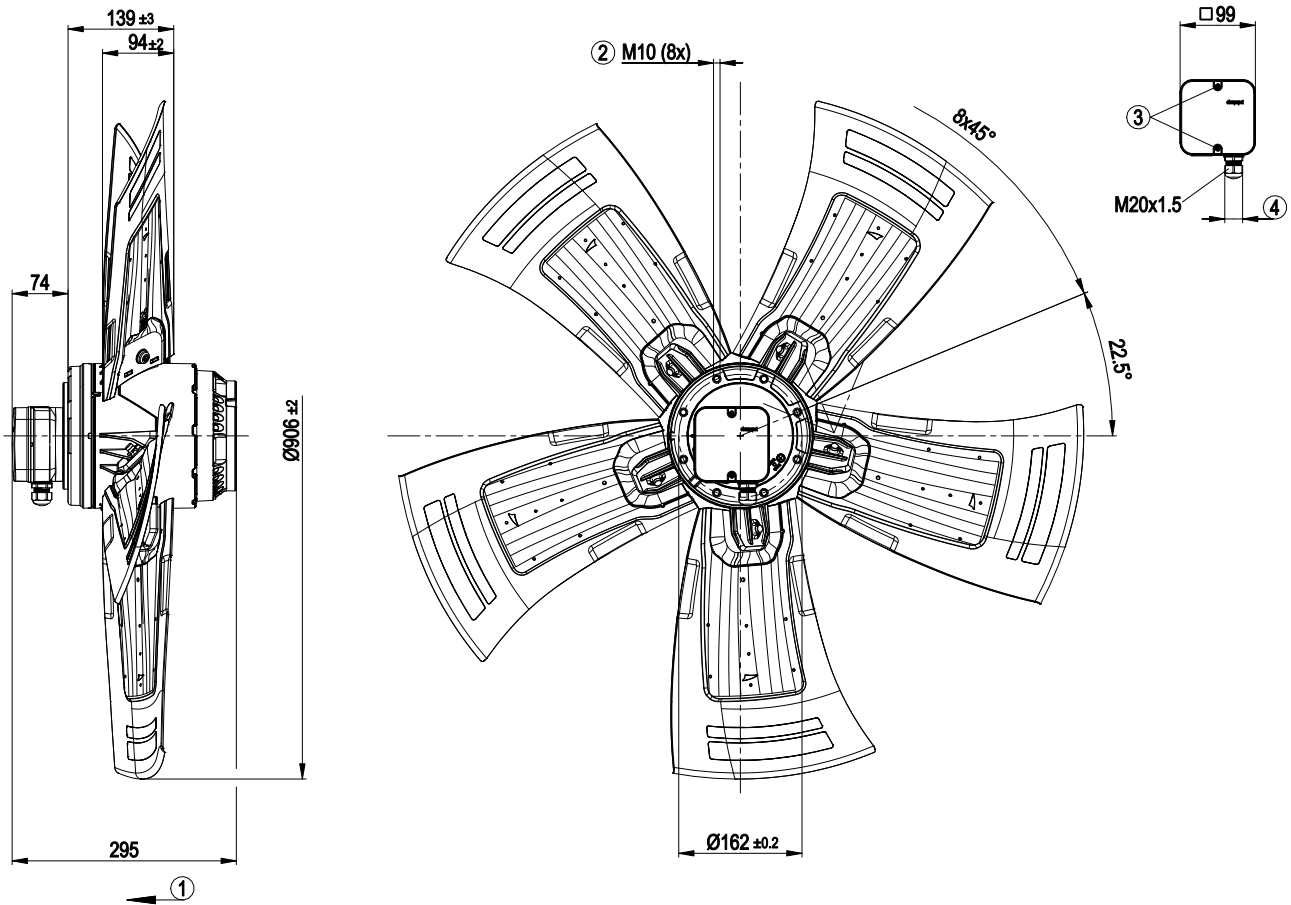

1	Direction of air flow "V"
2	Max. clearance for screw 18 mm
3	Tightening torque 1.5 ± 0.2 Nm
4	Cable diameter: min. 7 mm, max. 14 mm; tightening torque 2.0 ± 0.30 Nm



# AC axial fan - HyBlade

sickle-shaped blades (S series)

## Connection diagram

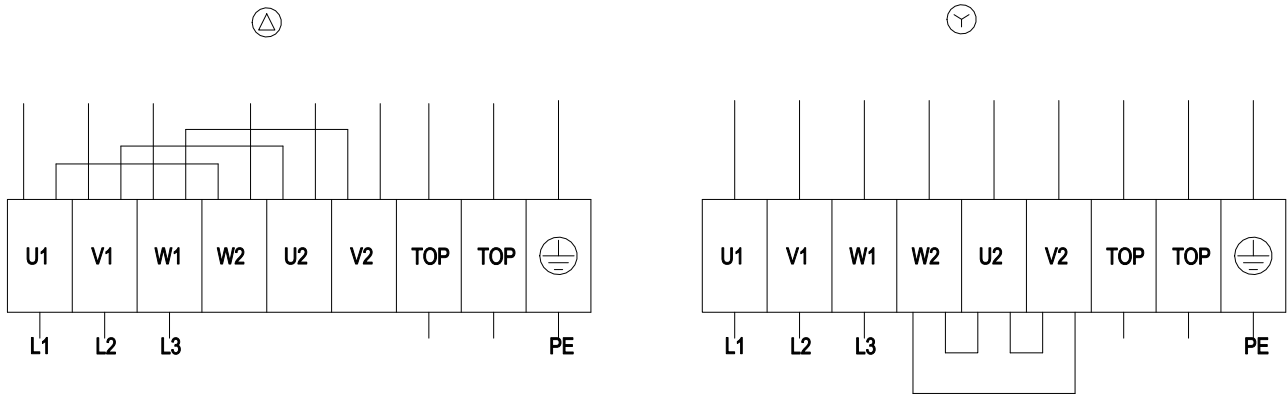

Δ	Delta connection	Y	Star connection	L1	= U1 = black
L2	= V1 = blue	L3	= W1 = brown	W2	yellow
U2	green	V2	white	TOP	2x gray
PE	green/yellow				



## Curves: Air performance 50 Hz

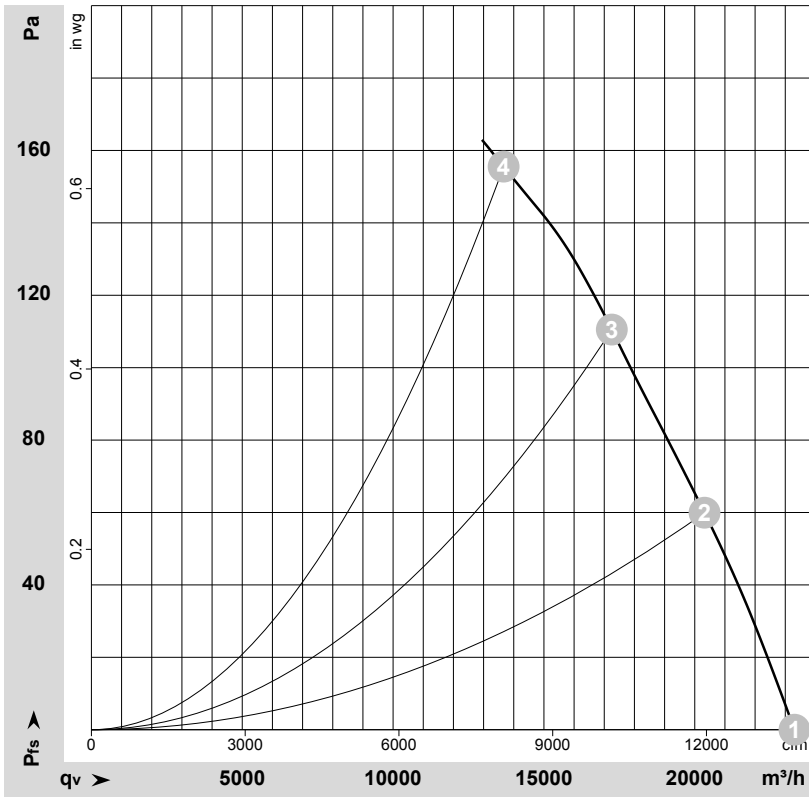

$\rho = 1.15 \text{ kg/m}^3 \pm 2 \%$

Measurement: LU-118455-1

Air performance measured according to ISO 5801 installation category A. For detailed information on the measurement setup, contact ebmpapst. Intake sound level: Sound power level according to ISO 13347 / sound pressure level measured at 1 m distance from fan axis. The values given are valid under the specified measuring conditions and may vary due to conditions of installation. For deviations from the standard configuration, the parameters have to be checked on the installed unit.

## Measured values

	Wired	U	f	n	P <sub>e</sub>	I	LpA <sub>in</sub>	LwA <sub>in</sub>	LwA <sub>out</sub>	qv	p <sub>fs</sub>
		V	Hz	min <sup>-1</sup>	W	A	dB(A)	dB(A)	dB(A)	m <sup>3</sup> /h	Pa
1	Y	400	50	970	918	3.86	73	80	80	23305	0
2	Y	400	50	960	1170	3.97	71	78	78	20325	60
3	Y	400	50	955	1359	4.11	71	79	78	17250	110
4	Y	400	50	945	1480	4.22	82	89	90	13665	155

Wired = Wiring · U = Power supply · f = Frequency · n = Speed · P<sub>e</sub> = Power consumption · I = Current draw · LpA<sub>in</sub> = Sound pressure level intake side · LwA<sub>in</sub> = Sound power level intake side  
 LwA<sub>out</sub> = Sound power level outlet side · qv = Air flow · p<sub>fs</sub> = Pressure increase



## Curves: Air performance 60 Hz

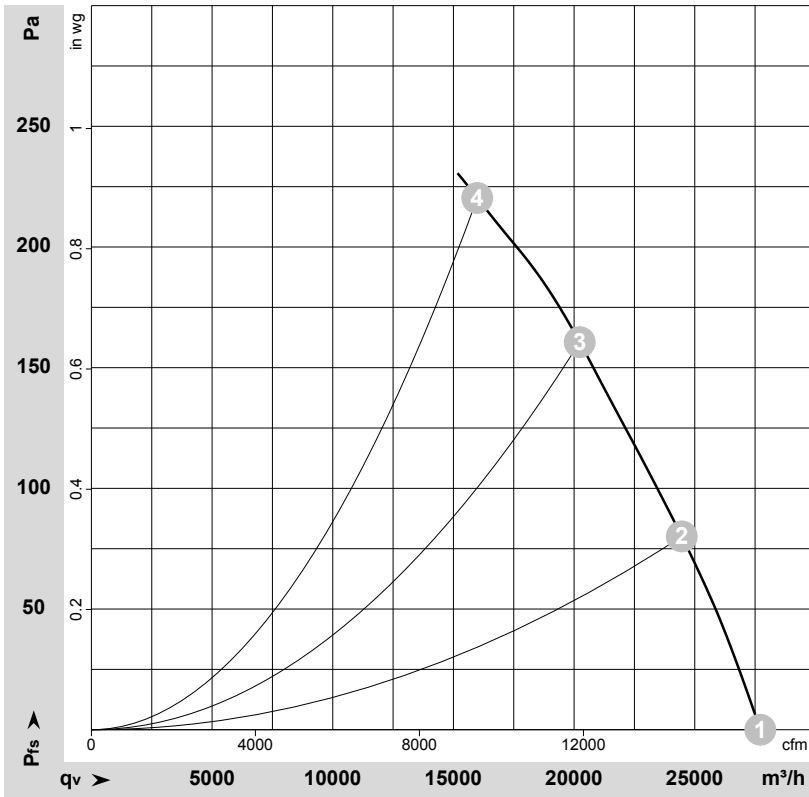

$\rho = 1.15 \text{ kg/m}^3 \pm 2 \%$

Measurement: LU-118468-1

Air performance measured according to ISO 5801 installation category A. For detailed information on the measurement setup, contact ebm-papst. Intake sound level: Sound power level according to ISO 13347 / sound pressure level measured at 1 m distance from fan axis. The values given are valid under the specified measuring conditions and may vary due to conditions of installation. For deviations from the standard configuration, the parameters have to be checked on the installed unit.

## Measured values

	Wired	U	f	n	P <sub>e</sub>	I	LpA <sub>in</sub>	LwA <sub>in</sub>	LwA <sub>out</sub>	qv	p <sub>fs</sub>
		V	Hz	min <sup>-1</sup>	W	A	dB(A)	dB(A)	dB(A)	m <sup>3</sup> /h	Pa
1	Y	480	60	1160	1422	3.95	78	85	85	27715	0
2	Y	480	60	1140	1840	4.27	76	83	82	24460	80
3	Y	480	60	1130	2218	4.58	76	83	83	20230	160
4	Y	480	60	1120	2410	4.76	86	94	94	15985	220

Wired = Wiring · U = Power supply · f = Frequency · n = Speed · P<sub>e</sub> = Power consumption · I = Current draw · LpA<sub>in</sub> = Sound pressure level intake side · LwA<sub>in</sub> = Sound power level intake side  
 LwA<sub>out</sub> = Sound power level outlet side · qv = Air flow · p<sub>fs</sub> = Pressure increase

