

A6D910-AB05-08 ebmpapst Datasheet

sales@fansco.com

www.fansco.com

Limited partnership · Headquarters Mulfingen
County court Stuttgart · HRA 590344General partner Elektrobau Mulfingen GmbH · Headquarters Mulfingen
County court Stuttgart · HRB 590142

Nominal data

Type	A6D910-AB05-08				
Motor	M6D138-NA				
Phase		3~	3~	3~	3~
Nominal voltage	VAC	230	277	400	480
Connection		Δ	Δ	Y	Y
Frequency	Hz	50	60	50	60
Type of data definition		ml	ml	ml	ml
Valid for approval / standard		CE	CE	CE	CE
Speed (rpm)	min ⁻¹	930	1100	930	1100
Power input	W	1890	2870	1890	2870
Current draw	A	7.9	8.9	4.6	5.13
Max. back pressure	Pa	130	140	130	140
Min. ambient temperature	°C	-40	-40	-40	-40
Max. ambient temperature	°C	75	45	75	45
Starting current	A	33	37	19	21.5

ml = Max. load · me = Max. efficiency · fa = Running at free air · cs = Customer specs · cu = Customer unit
Subject to alterations

Data according to ErP directive

		Actual	Request 2015			
01 Overall efficiency η_{es}	%	39.1	35.5	09 Power input P_e	kW	1.93
02 Measurement category		A		09 Air flow q_v	m ³ /h	18700
03 Efficiency category		Static		09 Pressure increase p_{fs}	Pa	146
04 Efficiency grade N		43.6	40	10 Speed (rpm) n	min ⁻¹	925
05 Variable speed drive		No		11 Specific ratio*		1.00

Data definition with optimum efficiency.
The ErP data is determined using a motor-impeller combination in a standardised measurement configuration.* Specific ratio = $1 + p_g / 100\,000\text{ Pa}$

LU-118443



Technical features

Mass	28.0 kg
Size	910 mm
Surface of rotor	Coated in black
Material of terminal box	Die-cast aluminium, coated in black
Material of blades	Aluminium sheet insert (coated in black), sprayed with PP plastic
Number of blades	5
Blade angle	-5°
Direction of air flow	"V"
Direction of rotation	Clockwise, seen on rotor
Type of protection	IP 55
Insulation class	"F"
Humidity (F)/environmental protection class (H)	H2+
Max. permissible ambient motor temp. (transp./ storage)	+80 °C
Min. permissible ambient motor temp. (transp./storage)	-40 °C
Mounting position	Any
Condensate discharge holes	On rotor and stator sides
Operation mode	S1
Motor bearing	Ball bearing
Touch current acc. IEC 60990 (measuring network Fig. 4, TN system)	<= 3.5 mA
Electrical leads	Via terminal box
Motor protection	Thermal overload protector (TOP) brought out, basic insulation
Cable exit	Axial
Protection class	I (if protective earth is connected by customer)
Product conforming to standard	EN 60034-1 (2010); EN 61800-5-1; CE
Approval	CSA C22.2 No.100; EAC; UL 1004-1

Product drawing

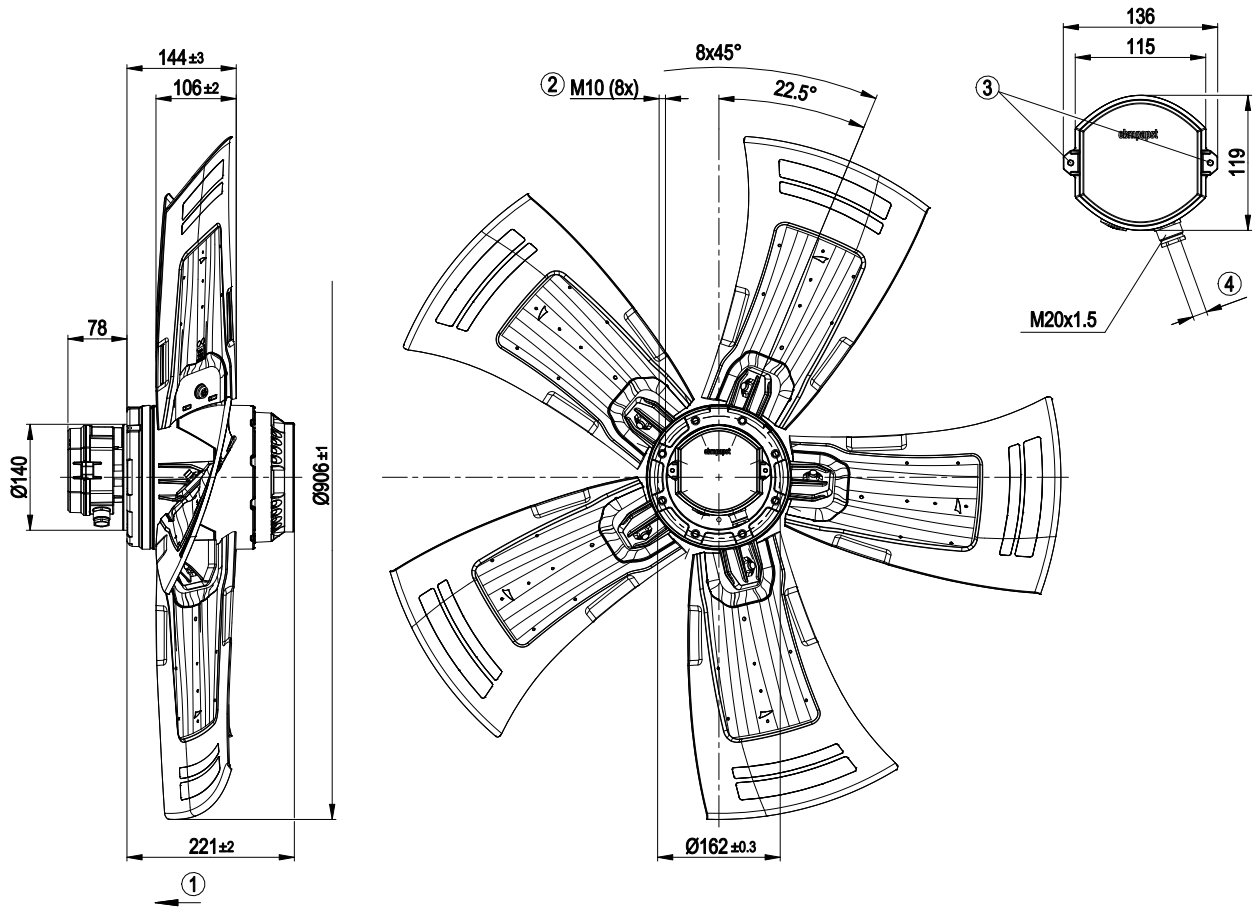

1	Direction of air flow "V"
2	Thread reach max. 18 mm
3	Tightening torque 2.5±0.4 Nm
4	Cable diameter: min. 10 mm, max. 12 mm, tightening torque 4±0.6 Nm



Connection screen

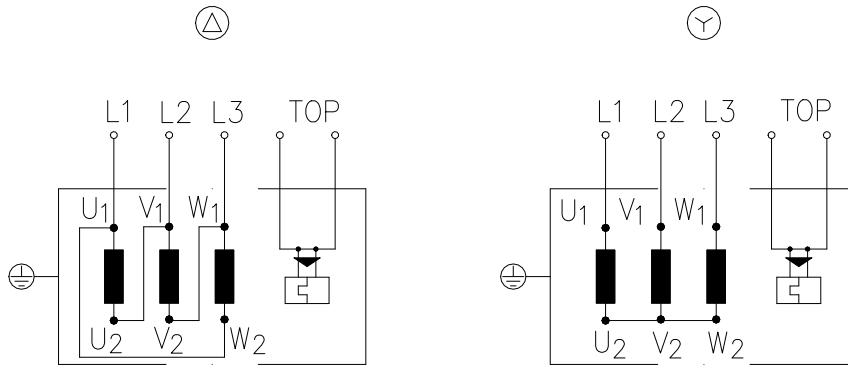

Changing the direction of rotation by reversing the two phases

Δ	Delta connection	Y	Star connection	L1	= U1 = black
L2	= V1 = blue	L3	= W1 = brown	W2	yellow
U2	green	V2	white	TOP	2 x grey
PE	green / yellow				



Charts: Air flow 50 Hz

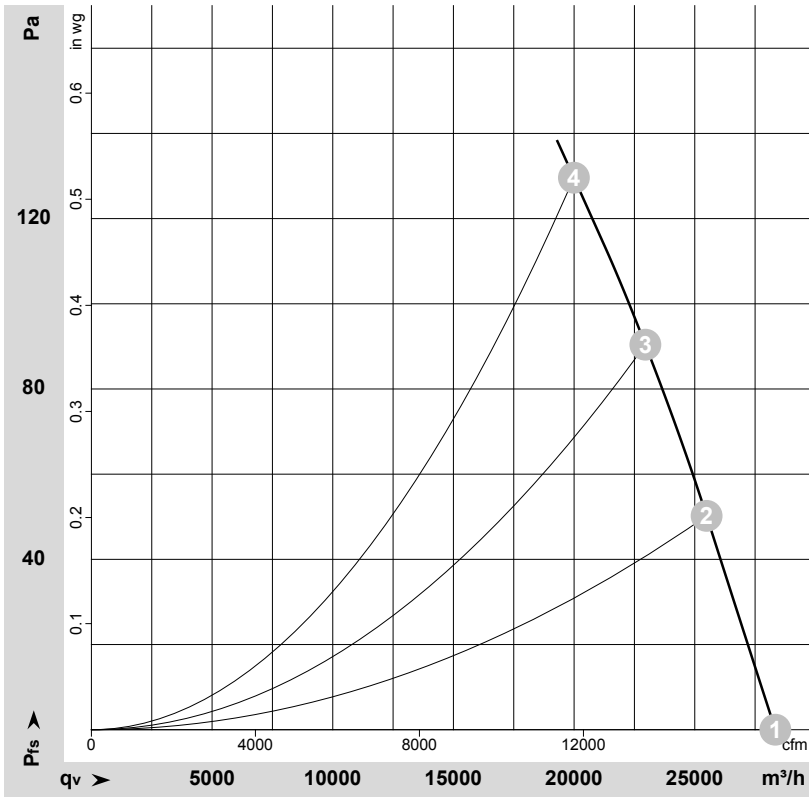

$\rho = 1.15 \text{ kg/m}^3 \pm 2 \%$

Measurement: LU-118443-1

Air performance measured as per ISO 5801 Installation category A. For detailed information on the measuring set-up, please contact ebmpapst. Suction-side noise levels: LwA measured as per ISO 13347 / LpA measured with 1m distance to fan axis. The values given are valid under the measuring conditions mentioned above and may vary according to the actual installation situation. With any deviation from the standard set-up, the specific values have to be checked and reviewed with the unit installed.

Measured values

	Conn.	U	f	n	P _e	I	LpA _{in}	LwA _{in}	LwA _{out}	q _v	p _{fs}	q _v	p _{fs}
		V	Hz	min ⁻¹	W	A	dB(A)	dB(A)	dB(A)	m ³ /h	Pa	cfm	inH2O
1	Y	400	50	955	1284	3.98	71	79	79	28340	0	16680	0.00
2	Y	400	50	945	1542	4.17	69	77	77	25490	50	15005	0.20
3	Y	400	50	940	1714	4.34	68	76	76	22955	90	13510	0.36
4	Y	400	50	930	1890	4.60	69	76	76	19990	130	11765	0.52

Conn. = Connection · U = Supply voltage · f = Frequency · n = Speed (rpm) · P_e = Power input · I = Current draw · LpA_{in} = Sound pressure level inlet side · LwA_{in} = Sound power level inlet side
 LwA_{out} = Sound power level outlet side · q_v = Air flow · p_{fs} = Pressure increase



Charts: Air flow 60 Hz

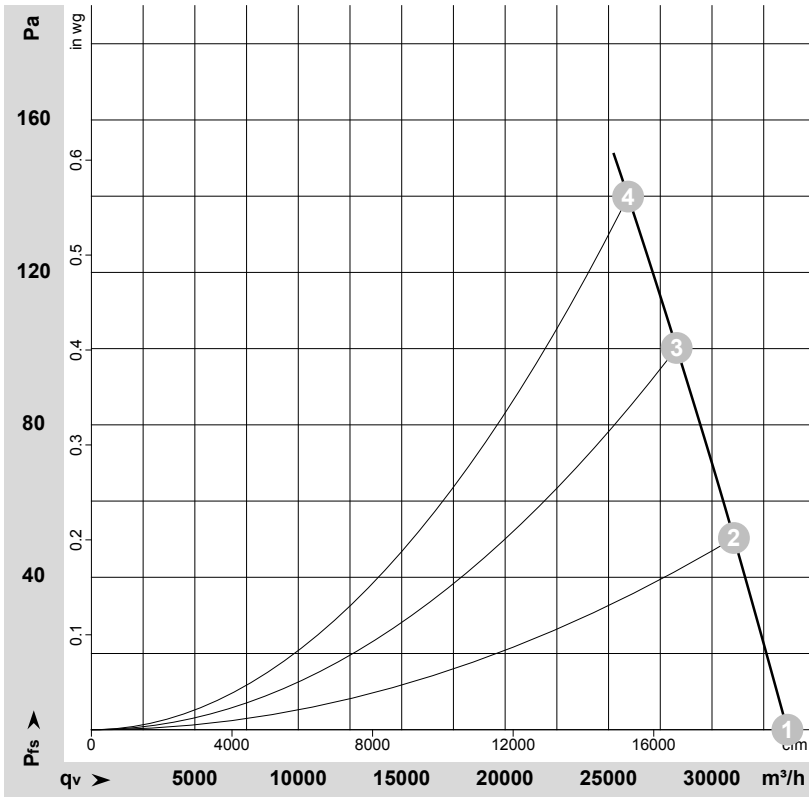

$\rho = 1.15 \text{ kg/m}^3 \pm 2 \%$

Measurement: LU-118449-1

Air performance measured as per ISO 5801 Installation category A. For detailed information on the measuring set-up, please contact ebmpapst. Suction-side noise levels: LwA measured as per ISO 13347 / LpA measured with 1m distance to fan axis. The values given are valid under the measuring conditions mentioned above and may vary according to the actual installation situation. With any deviation from the standard set-up, the specific values have to be checked and reviewed with the unit installed.

Measured values

	Conn.	U	f	n	Pe	I	LpA _{in}	LwA _{in}	LwA _{out}	qv	Pfs	qv	Pfs
		V	Hz	min ⁻¹	W	A	dB(A)	dB(A)	dB(A)	m ³ /h	Pa	cfm	inH2O
1	Y	480	60	1130	2073	4.26	76	83	83	33645	0	19805	0.00
2	Y	480	60	1120	2375	4.57	74	82	82	31060	50	18280	0.20
3	Y	480	60	1110	2649	4.86	73	81	81	28290	100	16650	0.40
4	Y	480	60	1100	2870	5.13	73	80	80	25945	140	15270	0.56

Conn. = Connection · U = Supply voltage · f = Frequency · n = Speed (rpm) · Pe = Power input · I = Current draw · LpA_{in} = Sound pressure level inlet side · LwA_{in} = Sound power level inlet side
LwA_{out} = Sound power level outlet side · qv = Air flow · Pfs = Pressure increase

