

A6D910-AB01-01 ebmpapst Datasheet FansCo

sales@fansco.com

www.fansco.com

## Nominal data

Type	A6D910-AB01-01		
Motor	M6D138-NA		
Phase		3~	3~
Nominal voltage	VAC	400	400
Connection		$\Delta$	Y
Frequency	Hz	50	50
Type of data definition		ml	ml
Valid for approval / standard		CE	CE
Speed	min <sup>-1</sup>	920	760
Power input	W	2020	1390
Current draw	A	4.62	2.6
Max. back pressure	Pa	160	105
Min. ambient temperature	°C	-40	-40
Max. ambient temperature	°C	60	60
Starting current	A	18.6	6.2

ml = Max. load · me = Max. efficiency · fa = Running at free air · cs = Customer specs · cu = Customer unit  
Subject to alterations

## Data according to ErP directive

		Actual	Request 2015			
01 Overall efficiency $\eta_{es}$	%	38.4	35.5	09 Power input $P_e$	kW	1.96
02 Measurement category		A		09 Air flow $q_v$	m <sup>3</sup> /h	18720
03 Efficiency category		Static		09 Pressure increase $p_{fs}$	Pa	145
04 Efficiency grade N		42.9	40	10 Speed n	min <sup>-1</sup>	925
05 Variable speed drive		No		11 Specific ratio*		1.00

Data definition with optimum efficiency.  
The ErP data is determined using a motor-impeller combination in a standardised measurement configuration.

\* Specific ratio =  $1 + p_g / 100\,000\text{ Pa}$ 

LU-117505



### Technical features

Mass	27.8 kg
Size	910 mm
Surface of rotor	Cast in aluminium
Material of terminal box	PP plastic
Material of blades	Aluminium sheet insert, sprayed with PP plastic
Number of blades	5
Blade angle	-5°
Direction of air flow	"V"
Direction of rotation	Clockwise, seen on rotor
Type of protection	IP 54
Insulation class	"F"
Humidity class	F3-1
Max. permissible ambient motor temp. (transp./ storage)	+ 80 °C
Min. permissible ambient motor temp. (transp./storage)	- 40 °C
Mounting position	Any
Condensate discharge holes	On rotor and stator sides
Operation mode	S1
Motor bearing	Ball bearing
Touch current acc. IEC 60990 (measuring network Fig. 4, TN system)	<= 3.5 mA
Electrical leads	Via terminal box
Motor protection	Thermal overload protector (TOP) brought out
Cable exit	Axial
Protection class	I (if protective earth is connected by customer)
Product conforming to standard	EN 60034-1 (2010); EN 61800-5-1; CE
Approval	EAC; VDE

# AC axial fan - HyBlade

sickled blades (S series)

## Product drawing

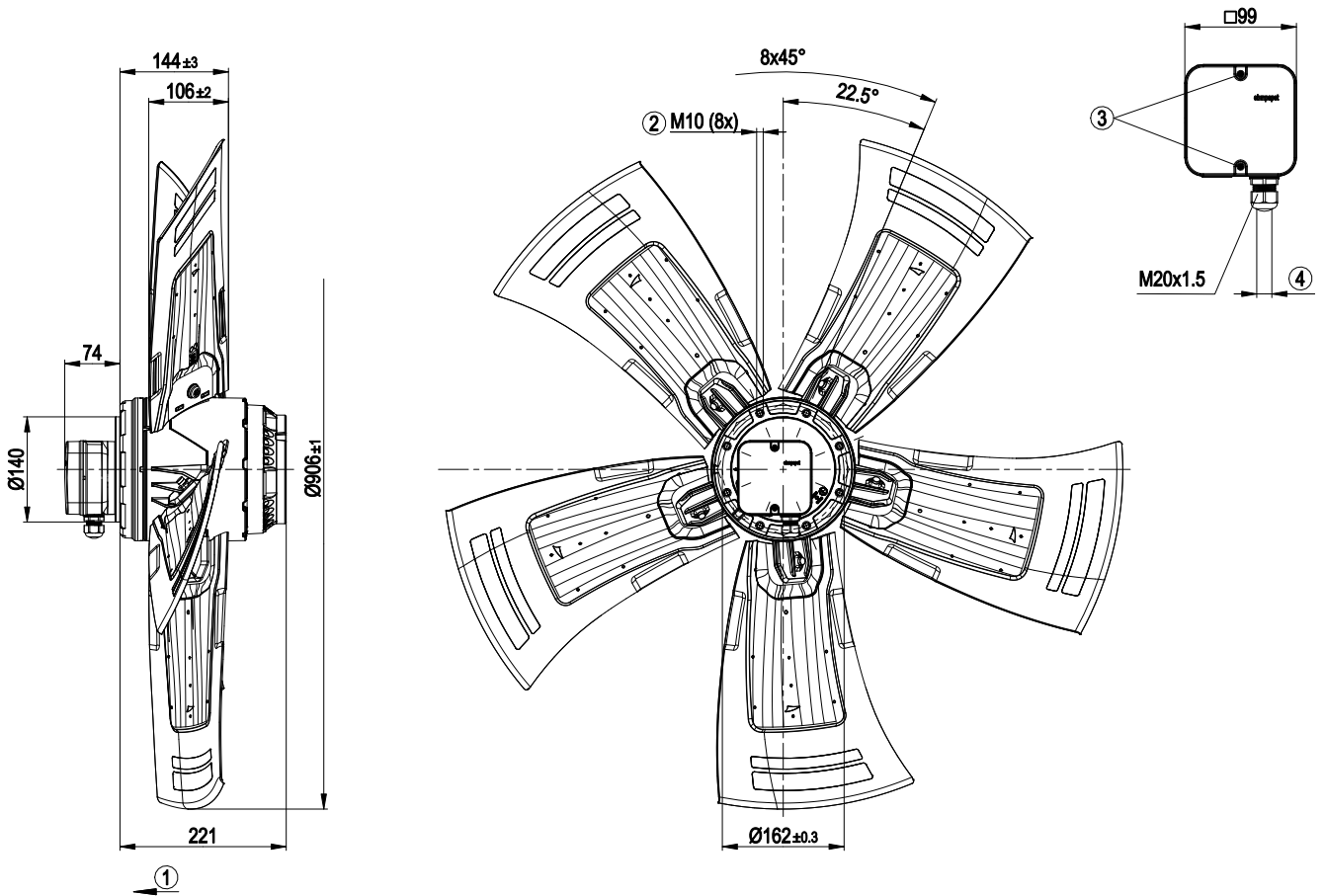

1	Direction of air flow "V"
2	Thread reach max. 18 mm
3	Tightening torque 1.5±0.2 Nm
4	Cable diameter min. 7 mm, max. 14 mm, tightening torque 2±0.3 Nm



## Connection screen

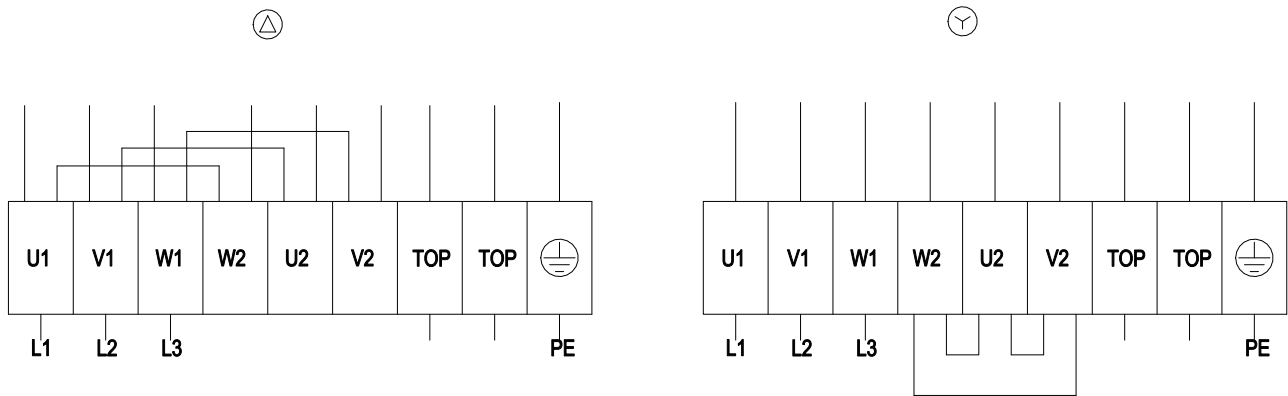

Δ	Delta connection	Y	Star connection	L1	= U1 = black
L2	= V1 = blue	L3	= W1 = brown	W2	yellow
U2	green	V2	white	TOP	2 x grey
PE	green/yellow				

## Charts: Air flow 50 Hz

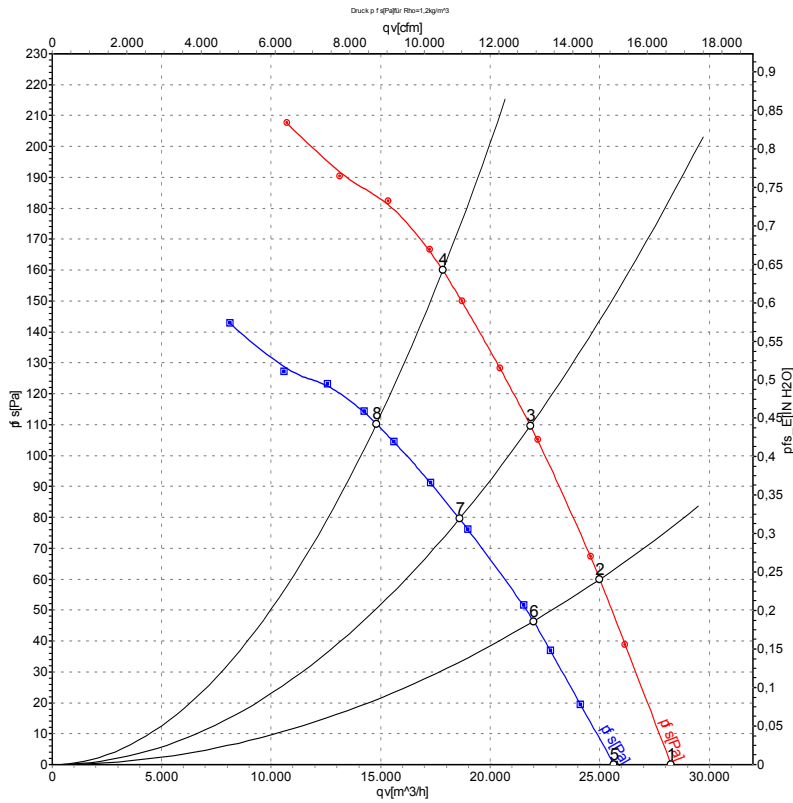

Measurement: LU-117505  
Measurement: LU-119168

Air performance measured as per ISO 5801 Installation category A. For detailed information on the measuring set-up, please contact ebm-papst. Suction-side noise levels: LwA measured as per ISO 13347 / LpA measured with 1m distance to fan axis. The values given are valid under the measuring conditions mentioned above and may vary according to the actual installation situation. With any deviation from the standard set-up, the specific values have to be checked and reviewed with the unit installed.

## Measured values

	Conn.	U	f	n	P <sub>e</sub>	I	LpA <sub>in</sub>	LwA <sub>in</sub>	LwA <sub>out</sub>	qv	p <sub>fs</sub>
		V	Hz	min <sup>-1</sup>	W	A	dB(A)	dB(A)	dB(A)	m <sup>3</sup> /h	Pa
1	Δ	400	50	955	1288	3.97	72	79	79	28260	0
2	Δ	400	50	940	1577	4.18	69	77	76	25000	60
3	Δ	400	50	930	1800	4.40	69	76	76	21830	110
4	Δ	400	50	920	2020	4.62	72	79	78	17840	160
5	Y	400	50	865	1000	1.88	69	76	76	25660	0
6	Y	400	50	825	1186	2.18	66	73	73	21980	46
7	Y	400	50	795	1305	2.40	65	72	72	18600	80
8	Y	400	50	760	1390	2.60	66	74	73	14810	110

Conn. = Connection · U = Supply voltage · f = Frequency · n = Speed · P<sub>e</sub> = Power input · I = Current draw · LpA<sub>in</sub> = Sound pressure level inlet side · LwA<sub>in</sub> = Sound power level inlet side  
LwA<sub>out</sub> = Sound power level outlet side · qv = Air flow · p<sub>fs</sub> = Pressure increase

