

A6D910-AA01-01 ebmpapst Datasheet FansCo

sales@fansco.com

www.fansco.com

Nominal data

| | | | |
|-------------------------------|-------------------|----------|------|
| Type | A6D910-AA01-01 | | |
| Motor | M6D138-NA | | |
| Phase | | 3~ | 3~ |
| Nominal voltage | VAC | 400 | 400 |
| Connection | | Δ | Y |
| Frequency | Hz | 50 | 50 |
| Type of data definition | | ml | ml |
| Valid for approval / standard | | CE | CE |
| Speed | min ⁻¹ | 885 | 685 |
| Power input | W | 2480 | 1570 |
| Current draw | A | 5.15 | 2.9 |
| Max. back pressure | Pa | 150 | 90 |
| Min. ambient temperature | °C | -40 | -40 |
| Max. ambient temperature | °C | 50 | 50 |
| Starting current | A | 18.6 | 6.2 |

ml = Max. load · me = Max. efficiency · fa = Running at free air · cs = Customer specs · cu = Customer unit
Subject to alterations

Data according to ErP directive

| | |
|-----------------------|--------|
| Installation category | A |
| Efficiency category | Static |
| Variable speed drive | No |
| Specific ratio* | 1.00 |

* Specific ratio = $1 + p_{fs} / 100\,000\text{ Pa}$

| | | Actual | Request 2013 | Request 2015 |
|--------------------------------|-------------------|--------|--------------|--------------|
| Overall efficiency η_{es} | % | 36.1 | 32.1 | 36.1 |
| Efficiency grade N | | 40 | 36 | 40 |
| Power input P_e | kW | 2.46 | | |
| Air flow q_v | m ³ /h | 21770 | | |
| Pressure increase p_{fs} | Pa | 142 | | |
| Speed n | min ⁻¹ | 890 | | |

Data definition with optimum efficiency. LU-136151
The ErP data is determined using a motor-impeller combination in a standardised measurement configuration.



Technical features

| | |
|--|--|
| Mass | 27.8 kg |
| Size | 910 mm |
| Surface of rotor | Cast in aluminium |
| Material of terminal box | PP plastic |
| Material of blades | Aluminium sheet insert, sprayed with PP plastic |
| Number of blades | 5 |
| Blade angle | 0° |
| Direction of air flow | "V" |
| Direction of rotation | Clockwise, seen on rotor |
| Type of protection | IP 54 |
| Insulation class | "F" |
| Humidity class | F3-1 |
| Max. permissible ambient motor temp. (transp./ storage) | +80 °C |
| Min. permissible ambient motor temp. (transp./storage) | -40 °C |
| Mounting position | Any |
| Condensate discharge holes | On rotor and stator sides |
| Operation mode | S1 |
| Motor bearing | Ball bearing |
| Touch current acc. IEC 60990 (measuring network Fig. 4, TN system) | <= 3.5 mA |
| Electrical leads | Via terminal box |
| Motor protection | Thermal overload protector (TOP) brought out |
| Cable exit | Axial |
| Protection class | I (if protective earth is connected by customer) |
| Product conforming to standard | EN 60034; EN 61800-5-1; CE |
| Approval | EAC; VDE |

Product drawing

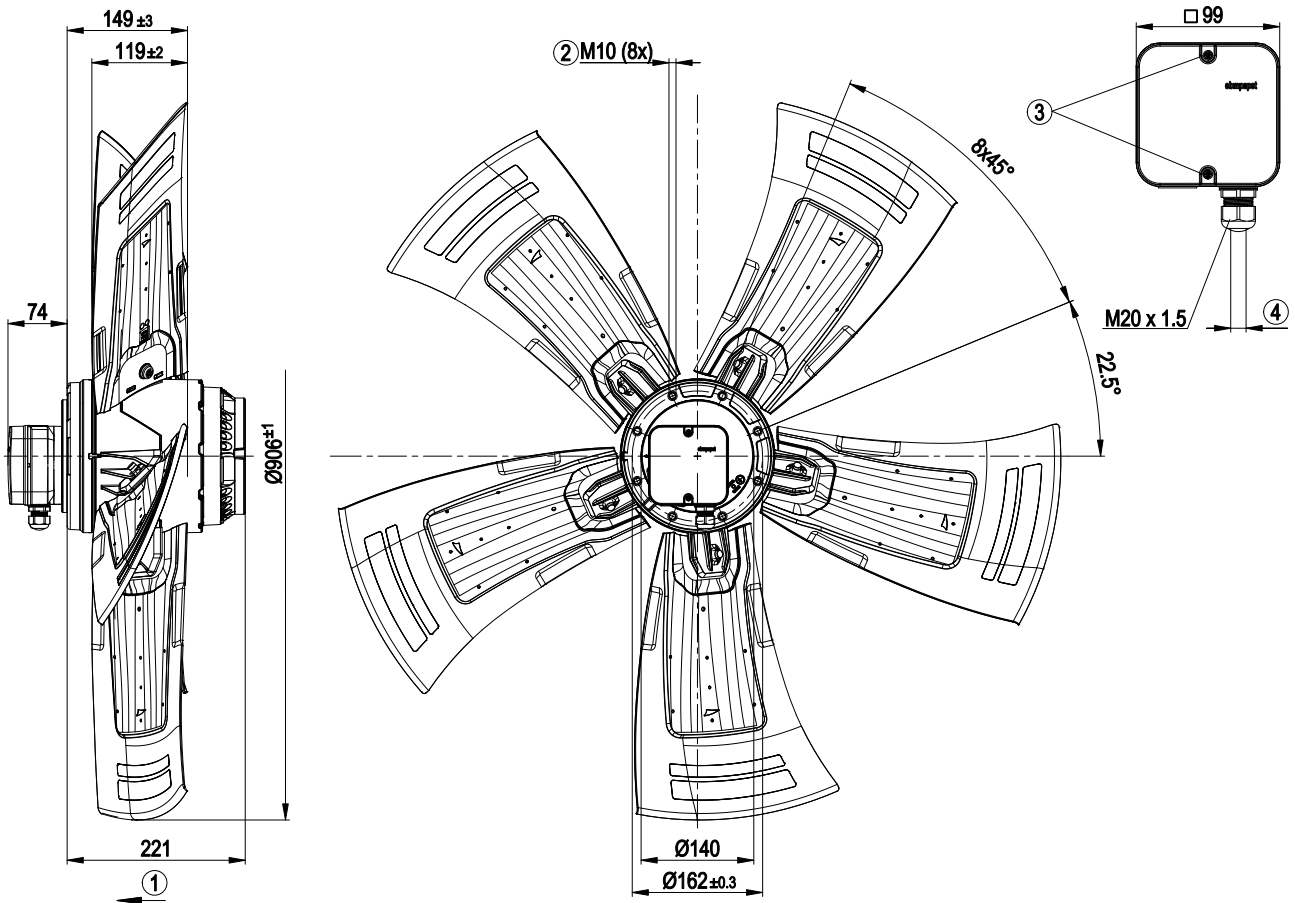

| | |
|---|--|
| 1 | Direction of air flow "V" |
| 2 | Depth of screw max. 18 mm |
| 3 | Tightening torque 1.5±0.2 Nm |
| 4 | Cable diameter: min. 7 mm, max. 14 mm; tightening torque: 2±0.3 Nm |

Connection screen

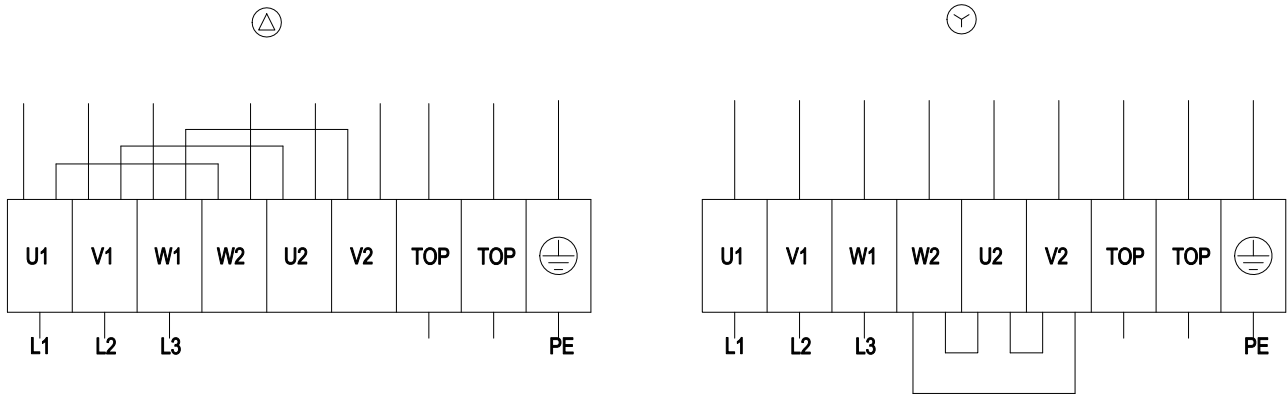

| | | | | | |
|----|------------------|----|-----------------|-----|--------------|
| Δ | Delta connection | Y | Star connection | L1 | = U1 = black |
| L2 | = V1 = blue | L3 | = W1 = brown | W2 | yellow |
| U2 | green | V2 | white | TOP | 2 x grey |
| PE | green/yellow | | | | |

Charts: Air flow 50 Hz

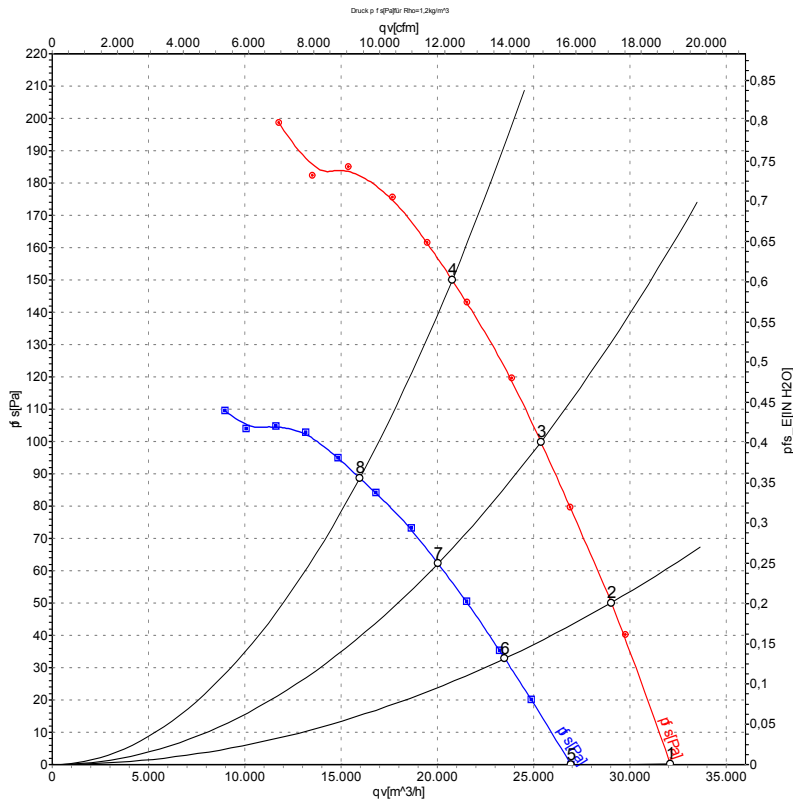

Air performance measured as per ISO 5801 Installation category A. For detailed information on the measuring set-up, please contact ebmpapst. Suction-side noise levels: LwA measured as per ISO 13347 / LpA measured with 1m distance to fan axis. The values given are valid under the measuring conditions mentioned above and may vary according to the actual installation situation. With any deviation from the standard set-up, the specific values have to be checked and reviewed with the unit installed.

Measured values

| | Conn. | U | f | n | P _e | I | LpA _{in} | LwA _{in} | LwA _{out} | qv | p _{fs} |
|---|-------|-----|----|-------------------|----------------|------|-------------------|-------------------|--------------------|-------------------|-----------------|
| | | V | Hz | min ⁻¹ | W | A | dB(A) | dB(A) | dB(A) | m ³ /h | Pa |
| 1 | Δ | 400 | 50 | 930 | 1786 | 4.38 | 70 | 77 | 78 | 32100 | 0 |
| 2 | Δ | 400 | 50 | 915 | 2050 | 4.67 | 68 | 75 | 75 | 29020 | 50 |
| 3 | Δ | 400 | 50 | 900 | 2262 | 4.88 | 68 | 75 | 75 | 25370 | 100 |
| 4 | Δ | 400 | 50 | 885 | 2480 | 5.15 | 70 | 77 | 77 | 20770 | 150 |
| 5 | Y | 400 | 50 | 785 | 1291 | 2.44 | 65 | 73 | 73 | 26940 | 0 |
| 6 | Y | 400 | 50 | 750 | 1410 | 2.67 | 63 | 70 | 70 | 23500 | 33 |
| 7 | Y | 400 | 50 | 715 | 1489 | 2.82 | 61 | 69 | 69 | 20030 | 62 |
| 8 | Y | 400 | 50 | 685 | 1570 | 2.90 | 63 | 71 | 70 | 15980 | 90 |

Conn. = Connection · U = Supply voltage · f = Frequency · n = Speed · P_e = Power input · I = Current draw · LpA_{in} = Sound pressure level inlet side · LwA_{in} = Sound power level inlet side · LwA_{out} = Sound power level outlet side · qv = Air flow · p_{fs} = Pressure increase

