

AC axial fan

sickled blades (S series)

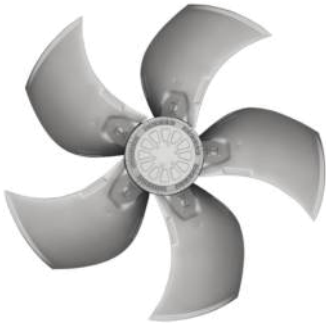

A6D800-AK05-07 ebmpapst Datasheet FansCo

sales@fansco.com

www.fansco.com

Nominal data

Type	A6D800-AK05-07								
Motor	M6D138-LA								
Phase		3~	3~	3~	3~	3~	3~	3~	3~
Nominal voltage	VAC	230	230	265	277	400	400	460	480
Connection		Δ	Δ	Δ	Δ	Y	Y	Y	Y
Frequency	Hz	50	60	60	60	50	60	60	60
Type of data definition		ml	ml	ml	ml	ml	ml	ml	ml
State				prelim.				prelim.	
Valid for approval / standard		CE	CE	CE	CE	CE	CE	CE	CE
Speed	min ⁻¹	905	1030	1035	1085	905	1030	1035	1085
Power input	W	1530	1960	1900	2160	1530	1960	1900	2160
Current draw	A	5.98	6.6	6.32	6.7	3.46	3.82	3.65	3.87
Max. back pressure	Pa	170	135	120	150	170	135	120	150
Max. ambient temperature	°C	60	60	60	60	60	60	60	60
Starting current	A	22	20			13	10		14

ml = max. load · me = max. efficiency · fa = running at free air · cs = customer specs · cu = customer unit
Subject to alterations

Data according to ErP directive

Installation category	A	Overall efficiency η_{es}	Actual	38.2	Request 2013	30.5	Request 2015	34.5
Efficiency category	Static	Efficiency grade N		43.7		36		40
Variable speed drive	No	Power input P_e	kW	1.33				
Specific ratio*	1.00	Air flow q_v	m ³ /h	15200				
		Pressure increase p_{fs}	Pa	122				
		Speed n	min ⁻¹	920				

Data established at point of optimum efficiency



Technical features

Mass	26.4 kg
Size	800 mm
Surface of rotor	Cast in aluminium
Material of terminal box	PC / ABS plastic
Material of blades	Die-cast aluminium
Number of blades	5
Blade angle	-5°
Direction of air flow	"V"
Direction of rotation	Clockwise, seen on rotor
Type of protection	IP 54
Insulation class	"F"
Humidity class	F3-1
Max. permissible ambient motor temp. (transp./ storage)	+ 80 °C
Min. permissible ambient motor temp. (transp./storage)	- 40 °C
Mounting position	Any
Condensate discharge holes	On rotor and stator sides
Operation mode	S1
Motor bearing	Ball bearing
Touch current acc. IEC 60990 (measuring network Fig. 4, TN system)	<= 3.5 mA
Electrical leads	Via terminal box
Motor protection	Thermal overload protector (TOP) brought out
Cable exit	Axial
Protection class	I (if protective earth is connected by customer)
Product conforming to standard	EN 60034; EN 61800-5-1; CE
Approval	UL 1004-1; CSA C22.2 Nr.100

Product drawing

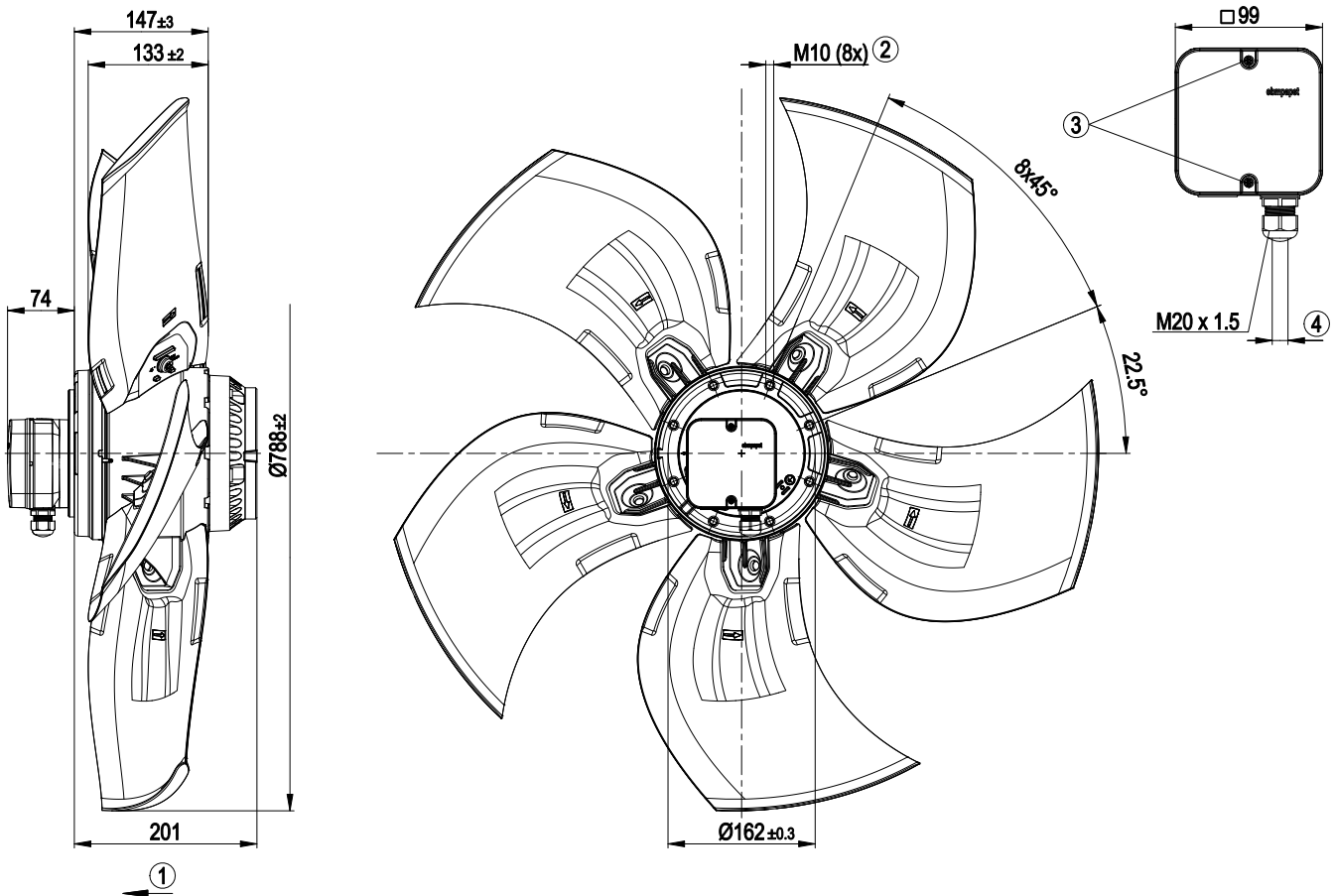

1	Direction of air flow "V"
2	Screw depth max. 18 mm
3	Tightening torque 1.5±0.2 Nm
4	Cable diameter: min. 7 mm, max. 14 mm; tightening torque: 2±0.3 Nm



Connection screen

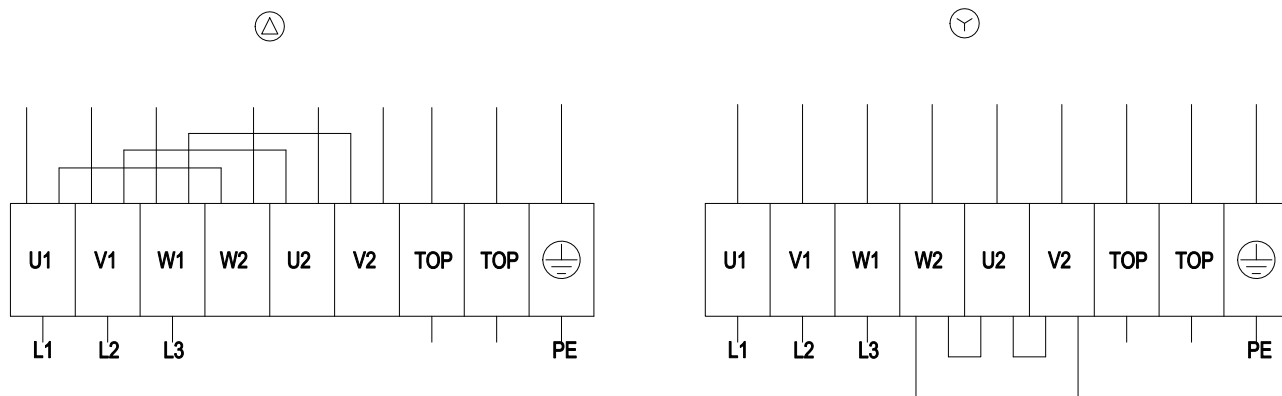

Δ	Delta connection	Y	Star connection	L1	= U1 = black
L2	= V1 = blue	L3	= W1 = brown	W2	yellow
U2	green	V2	white	TOP	2 x grey
PE	green/yellow				

Charts: Air flow 50 Hz

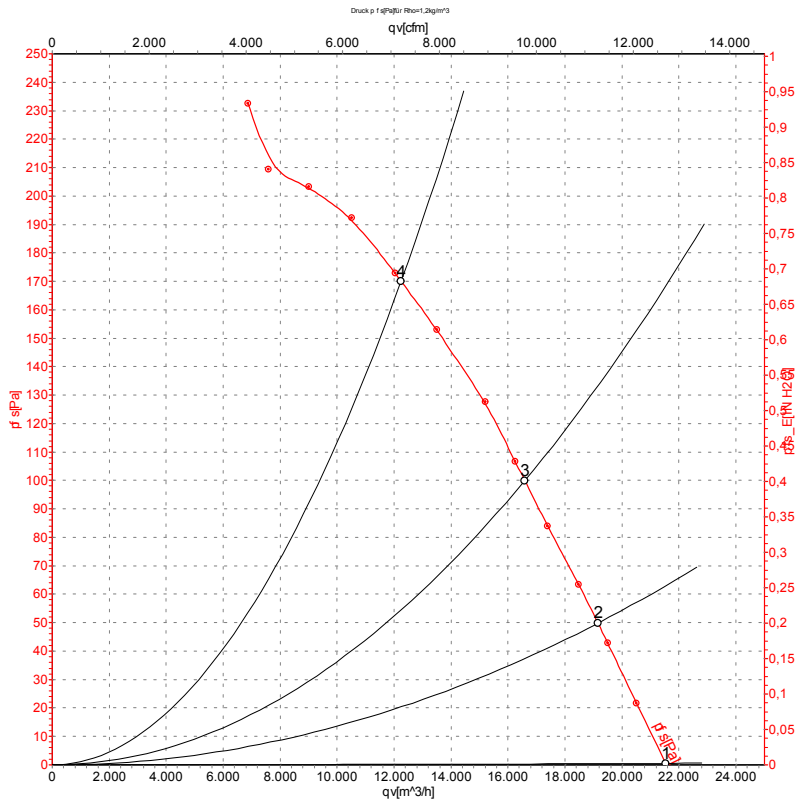

Measurement: LU-101334

Air performance measured as per ISO 5801 Installation category A. For detailed information on the measuring set-up, please contact ebm-papst. Suction-side noise levels: LwA measured as per ISO 13347 / LpA measured with 1m distance to fan axis. The values given are valid under the measuring conditions mentioned above and may vary according to the actual installation situation. With any deviation from the standard set-up, the specific values have to be checked and reviewed with the unit installed.

Measured values

	Conn.	U	f	n	P _e	I	LpA _{in}	LwA _{in}	qv	p _{fs}
		V	Hz	min ⁻¹	W	A	dB(A)	dB(A)	m ³ /h	Pa
1	Y	400	50	950	970	2.84	69	75	21560	0
2	Y	400	50	935	1148	3.02	65	72	19150	50
3	Y	400	50	925	1281	3.16	66	73	16590	100
4	Y	400	50	905	1530	3.46	69	76	12250	170

Conn. = Connection · U = Supply voltage · f = Frequency · n = Speed · P_e = Power input · I = Current draw · LpA_{in} = Sound pressure level inlet side · LwA_{in} = Sound power level inlet side
 qv = Air flow · p_{fs} = Pressure increase



Charts: Air flow 60 Hz

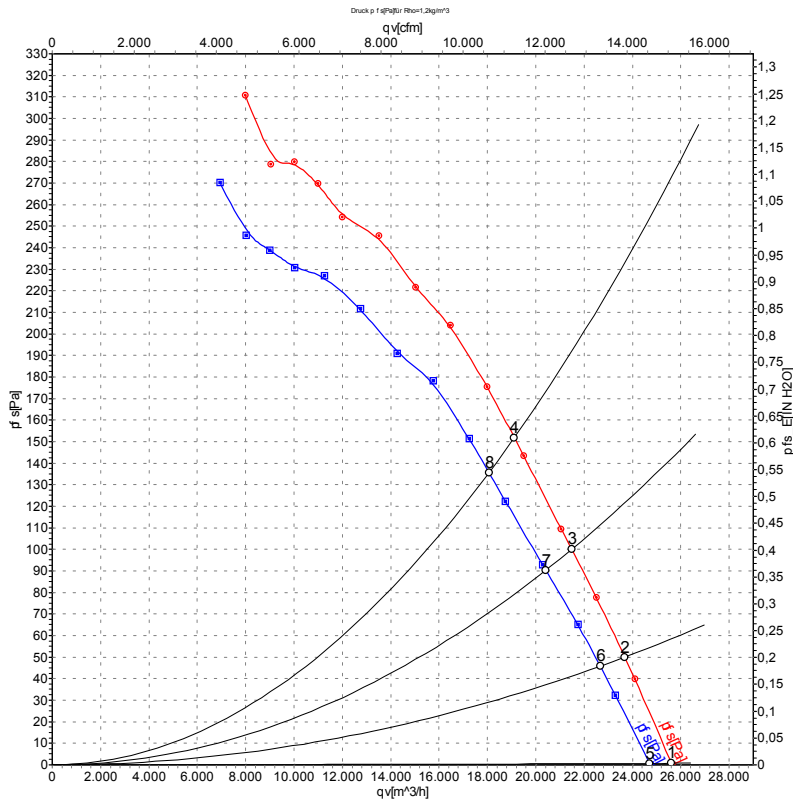

Measurement: LU-101330
Measurement: LU-101332

Air performance measured as per ISO 5801 Installation category A. For detailed information on the measuring set-up, please contact ebm-papst. Suction-side noise levels: LwA measured as per ISO 13347 / LpA measured with 1m distance to fan axis. The values given are valid under the measuring conditions mentioned above and may vary according to the actual installation situation. With any deviation from the standard set-up, the specific values have to be checked and reviewed with the unit installed.

Measured values

	Conn.	U	f	n	P _e	I	LpA _{in}	LwA _{in}	qv	p _{fs}
		V	Hz	min ⁻¹	W	A	dB(A)	dB(A)	m ³ /h	Pa
1	Y	480	60	1125	1604	3.26	72	79	25645	0
2	Y	480	60	1110	1820	3.49	69	76	23680	50
3	Y	480	60	1100	1994	3.68	68	74	21480	100
4	Y	480	60	1085	2160	3.87	69	75	19110	150
5	Y	400	60	1080	1494	3.08	71	78	24740	0
6	Y	400	60	1065	1654	3.34	68	75	22670	46
7	Y	400	60	1045	1818	3.60	66	73	20420	90
8	Y	400	60	1030	1960	3.82	68	74	18060	135

Conn. = Connection · U = Supply voltage · f = Frequency · n = Speed · P_e = Power input · I = Current draw · LpA_{in} = Sound pressure level inlet side · LwA_{in} = Sound power level inlet side
qv = Air flow · p_{fs} = Pressure increase

