

# AC axial fan

sickled blades (S series)

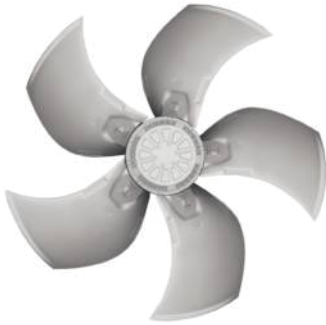

A6D800-AJ01-02 ebmpapst Datasheet  
 sales@fansco.com  
 www.fansco.com

Limited partnership · Headquarters Mulfingen  
 County court Stuttgart · HRA 590344

General partner Elektrobau Mulfingen GmbH · Headquarters Mulfingen  
 County court Stuttgart · HRB 590142



## Nominal data

Type	A6D800-AJ01-02			
Motor	M6D138-LA			
Phase		3~	3~	3~
Nominal voltage	VAC	400	400	415
Connection		Δ	Y	Δ
Frequency	Hz	50	50	50
Type of data definition		ml	ml	ml
Valid for approval / standard		CE	CE	CE
Speed	min <sup>-1</sup>	895	685	915
Power input	W	2000	1270	1690
Current draw	A	4.3	2.5	3.7
Max. back pressure	Pa	180	100	90
Max. ambient temperature	°C	50	50	60
Starting current	A	13	4.3	

ml = Max. load · me = Max. efficiency · fa = Running at free air · cs = Customer specs · cu = Customer unit  
 Subject to alterations

## Data according to ErP directive

Installation category	A	Overall efficiency $\eta_{es}$	%	Actual 35.4	Request 2013 31.2	Request 2015 35.2
Efficiency category	Static	Efficiency grade N		40.2	36	40
Variable speed drive	No	Power input $P_e$	kW	1.76		
Specific ratio <sup>*</sup>	1.00	Air flow $q_v$	m <sup>3</sup> /h	17035		
		Pressure increase $p_{fs}$	Pa	132		
		Speed n	min <sup>-1</sup>	900		

Data definition with optimum efficiency.  
 The ErP data is determined using a motor-impeller combination in a standardised measurement configuration.

LU-100640



# AC axial fan

sickled blades (S series)

## Technical features

Mass	26.4 kg
Size	800 mm
Surface of rotor	Cast in aluminium
Material of terminal box	ABS plastic, black
Material of blades	Die-cast aluminium
Number of blades	5
Blade angle	0
Direction of air flow	"A"
Direction of rotation	Counter-clockwise, seen on rotor
Type of protection	IP 54
Insulation class	"F"
Humidity class	F3-1
Max. permissible ambient motor temp. (transp./ storage)	+ 80 °C
Min. permissible ambient motor temp. (transp./storage)	- 40 °C
Mounting position	Any
Condensate discharge holes	On rotor and stator sides
Operation mode	S1
Motor bearing	Ball bearing
Touch current acc. IEC 60990 (measuring network Fig. 4, TN system)	<= 3.5 mA
Electrical leads	Via terminal box
Motor protection	Thermal overload protector (TOP) brought out
Cable exit	Axial
Protection class	I (if protective earth is connected by customer)
Product conforming to standard	EN 60034; EN 61800-5-1; CE
Approval	EAC; VDE



Product drawing

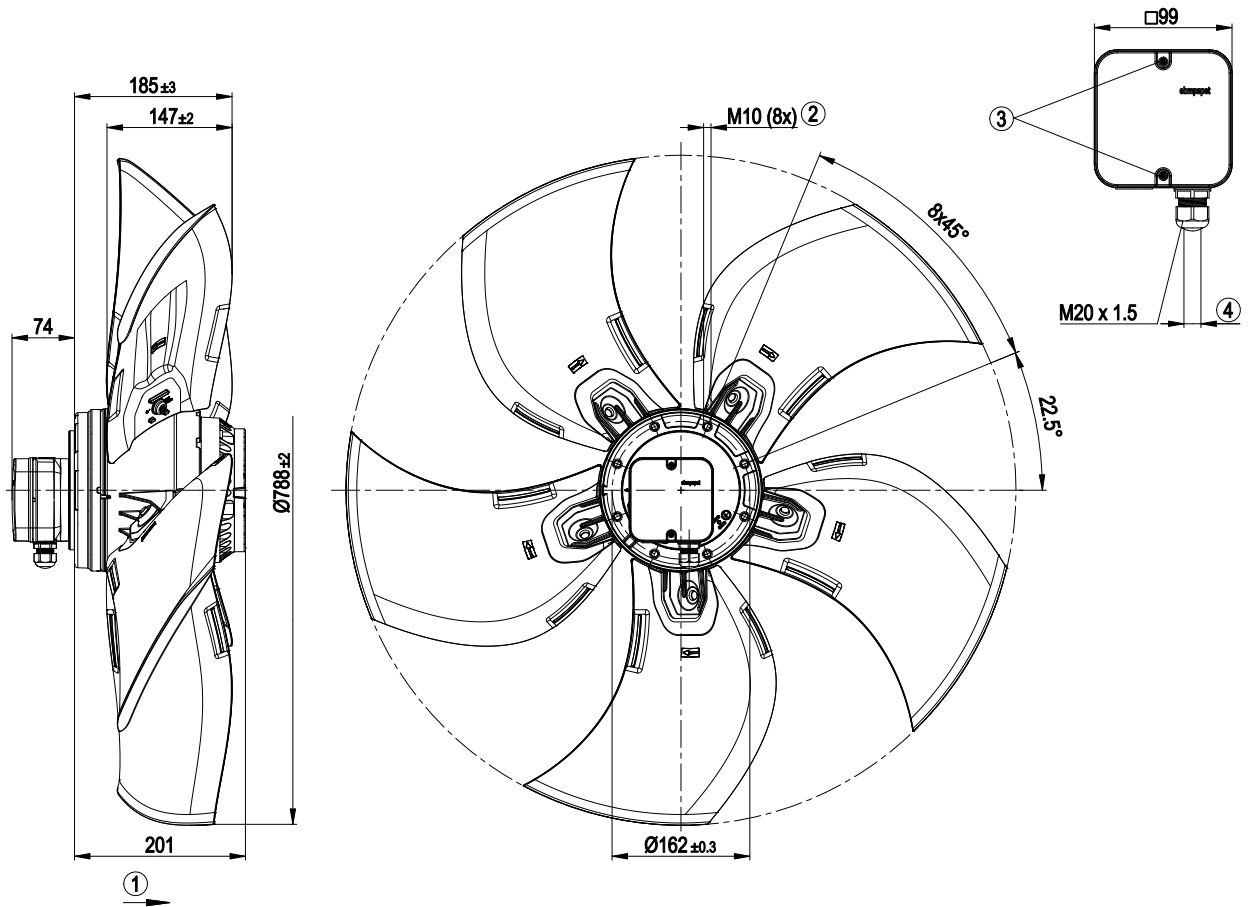

1	Direction of air flow "A"
2	Screw depth max. 18 mm
3	Tightening torque 1.5 Nm±0.2 Nm
4	Cable diameter: min. 7 mm, max. 14 mm, tightening torque: 2±0.3 Nm



Connection screen

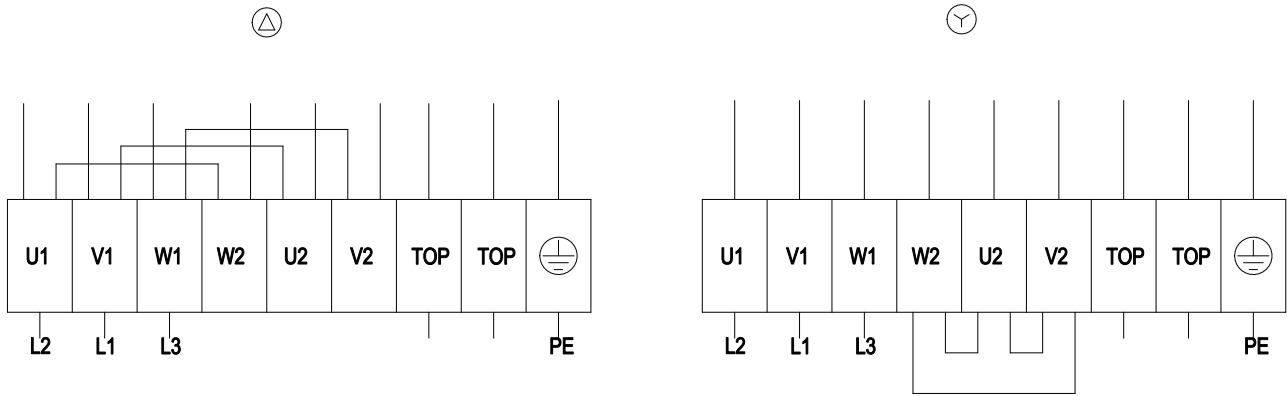

Δ	Delta connection	Y	Star connection	L1	= V1 = blue
L2	= U1 = black	L3	= W1 = brown	W2	yellow
U2	green	V2	white	TOP	2 x grey
PE	green/yellow				

## Charts: Air flow 50 Hz

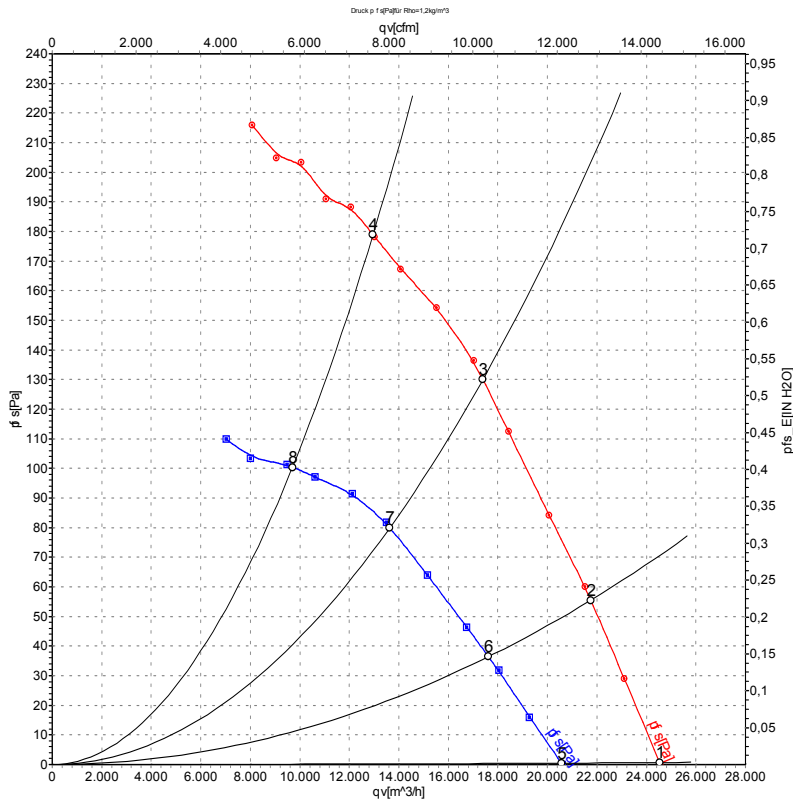

Air performance measured as per ISO 5801 Installation category A. For detailed information on the measuring set-up, please contact ebm-papst. Suction-side noise levels: LwA measured as per ISO 13347 / LpA measured with 1m distance to fan axis. The values given are valid under the measuring conditions mentioned above and may vary according to the actual installation situation. With any deviation from the standard set-up, the specific values have to be checked and reviewed with the unit installed.

## Measured values

	Conn.	U	f	n	P <sub>e</sub>	I	LpA <sub>in</sub>	LwA <sub>in</sub>	qv	p <sub>fs</sub>
		V	Hz	min <sup>-1</sup>	W	A	dB(A)	dB(A)	m <sup>3</sup> /h	Pa
1	Δ	400	50	930	1440	3.50	67	73	24530	0
2	Δ	400	50	915	1561	3.50	65	71	21750	55
3	Δ	400	50	900	1749	3.63	66	72	17390	130
4	Δ	400	50	895	2000	4.30	71	78	12960	180
5	Y	400	50	785	1030	1.90	63	70	20570	0
6	Y	400	50	750	1080	2.02	61	68	17620	36
7	Y	400	50	705	1157	2.17	61	67	13630	80
8	Y	400	50	685	1270	2.50	64	72	9705	100

Conn. = Connection · U = Supply voltage · f = Frequency · n = Speed · P<sub>e</sub> = Power input · I = Current draw · LpA<sub>in</sub> = Sound pressure level inlet side · LwA<sub>in</sub> = Sound power level inlet side  
 qv = Air flow · p<sub>fs</sub> = Pressure increase

