

A6D800-AI11-06 ebmpapst Datasheet

sales@fansco.com

www.fansco.com

## Nominal data

<b>Type</b>	A6D800-AI11-06		
<b>Motor</b>	M6D138-HF		
Phase		3~	3~
Nominal voltage	VAC	230	400
Connection		Δ	Y
Frequency	Hz	60	60
Type of data definition		ml	ml
Valid for approval / standard		CE	CE
Speed	min <sup>-1</sup>	995	995
Power input	W	1440	1440
Current draw	A	4.75	2.75
Max. back pressure	Pa	130	130
Min. ambient temperature	°C	-40	-40
Max. ambient temperature	°C	65	65
Starting current	A	12.2	7.1

ml = Max. load · me = Max. efficiency · fa = Running at free air · cs = Customer specs · cu = Customer unit  
 Subject to alterations

## Data according to ErP directive

Installation category	A
Efficiency category	Static
Variable speed drive	No
Specific ratio*	1.00

\* Specific ratio =  $1 + p_{fs} / 100\,000\text{ Pa}$

		Actual	Request 2013	Request 2015
Overall efficiency $\eta_{es}$	%	34.7	30.7	34.7
Efficiency grade N		40	36	40
Power input $P_e$	kW	1.47		
Air flow $q_v$	m <sup>3</sup> /h	12510		
Pressure increase $p_{fs}$	Pa	142		
Speed n	min <sup>-1</sup>	990		

Data definition with optimum efficiency. LU-142418  
 The ErP data is determined using a motor-impeller combination in a standardised measurement configuration.



A6D800-AI11-06

Emerson

# AC axial fan

sickled blades (S series)

## Technical features

Mass	20.5 kg
Size	800 mm
Surface of rotor	Cast in aluminium
Material of terminal box	PP plastic
Material of blades	Aluminium sheet insert, sprayed with PP plastic
Number of blades	5
Blade angle	-10°
Direction of air flow	"V"
Direction of rotation	Clockwise, seen on rotor
Type of protection	IP 54
Insulation class	"F"
Humidity class	F3-1
Max. permissible ambient motor temp. (transp./ storage)	+ 80 °C
Min. permissible ambient motor temp. (transp./storage)	- 40 °C
Mounting position	Any
Condensate discharge holes	On rotor and stator sides
Operation mode	S1
Motor bearing	Ball bearing
Touch current acc. IEC 60990 (measuring network Fig. 4, TN system)	<= 3.5 mA
Electrical leads	Via terminal box
Motor protection	Thermal overload protector (TOP) brought out
Protection class	I (if protective earth is connected by customer)
Product conforming to standard	EN 60034-1 (2010); EN 61800-5-1; CE
Approval	EAC; UL 1004-1; CSA C22.2 Nr.100



A6D800-AI11-06

Emerson

# AC axial fan

sickled blades (S series)

## Product drawing

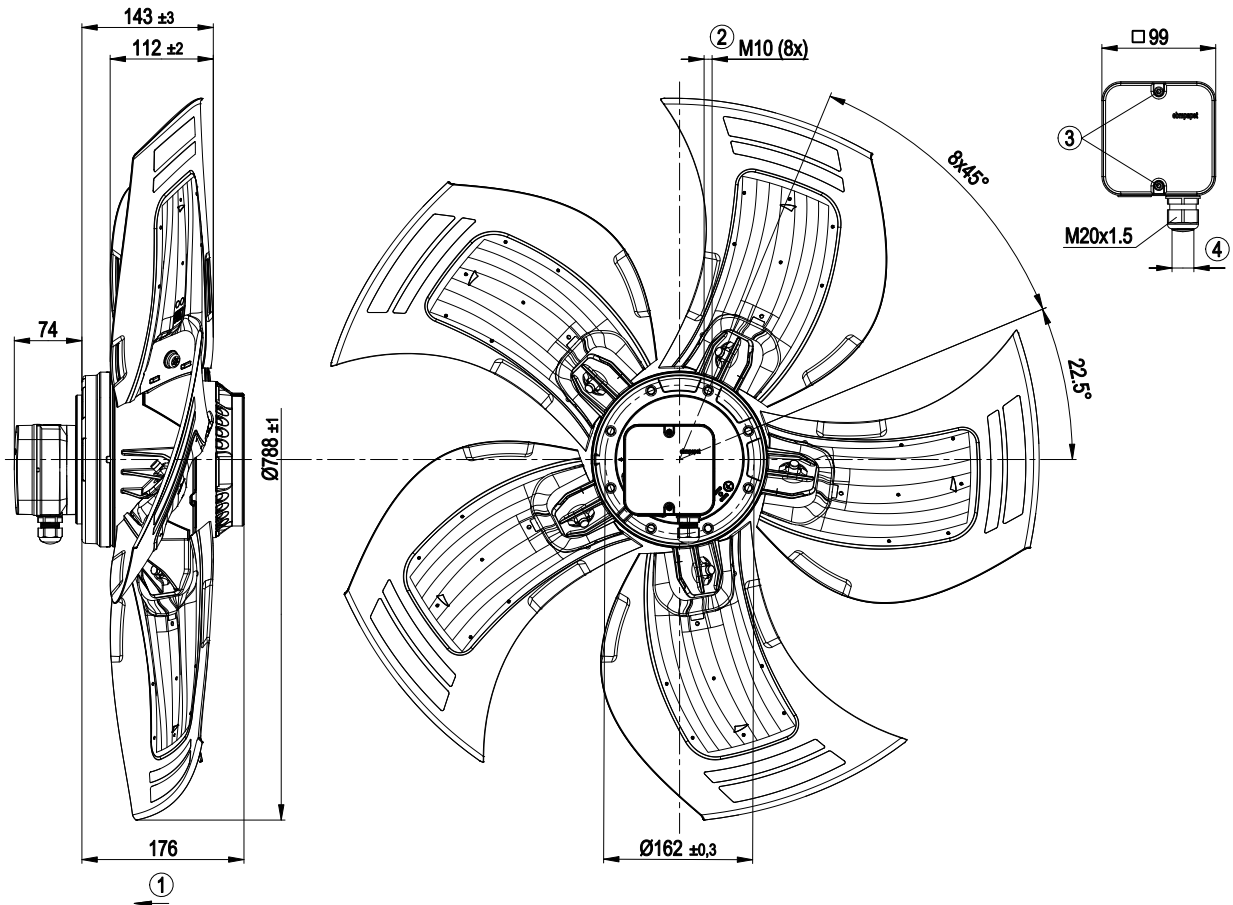

1	Direction of air flow "V"
2	Depth of screw max. 18 mm
3	Tightening torque 1.5±0.2 Nm
4	Cable diameter: min. 7 mm; max. 14 mm; tightening torque: 2±0.3 Nm



## Connection screen

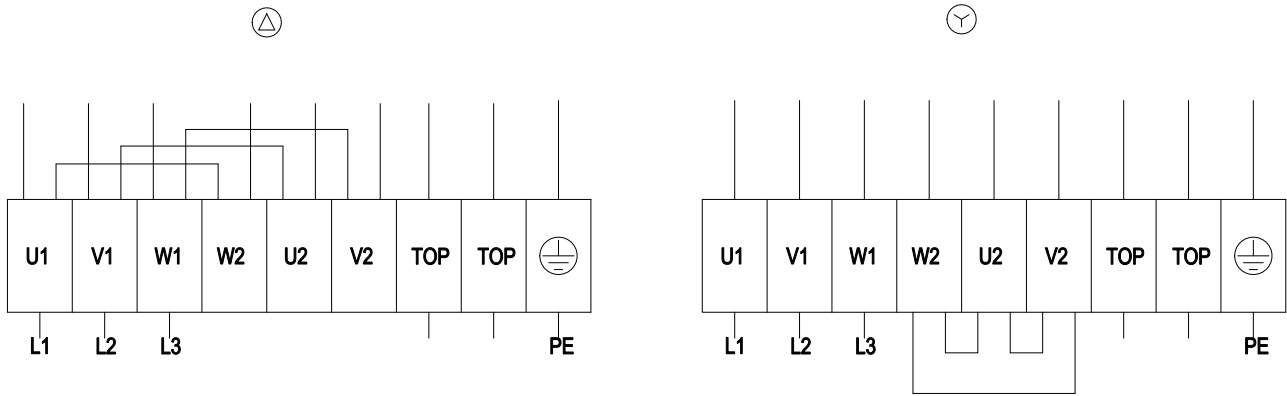

Δ	Delta connection	Y	Star connection	L1	= U1 = black
L2	= V1 = blue	L3	= W1 = brown	W2	yellow
U2	green	V2	white	TOP	2 x grey
PE	green/yellow				

Charts: Air flow 60 Hz

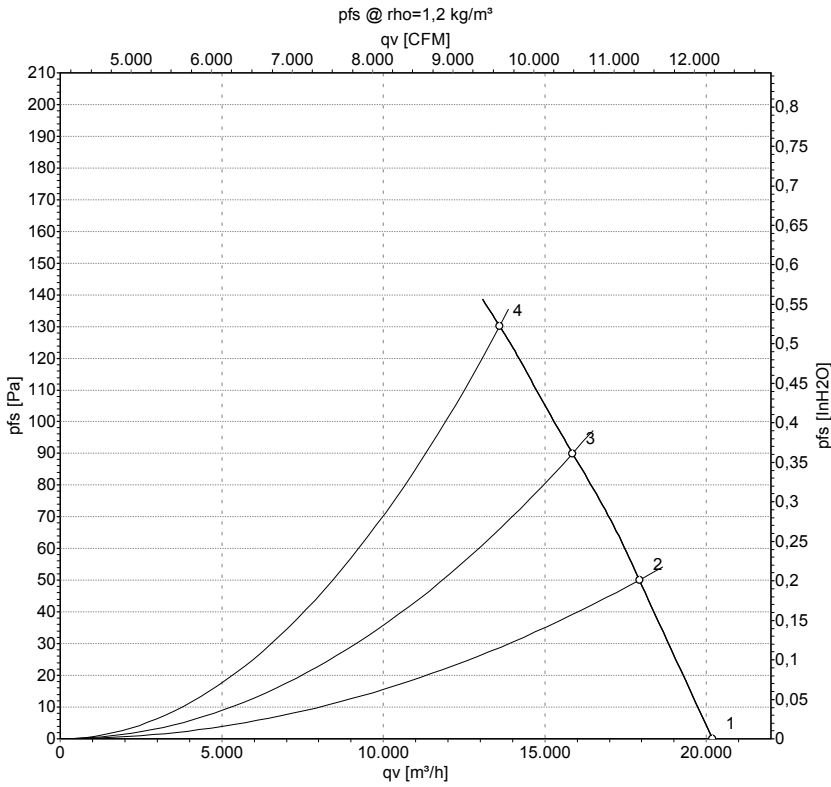

Measurement: LU-142418

Air performance measured as per ISO 5801 Installation category A. For detailed information on the measuring set-up, please contact ebm-papst. Suction-side noise levels: LwA measured as per ISO 13347 / LpA measured with 1m distance to fan axis. The values given are valid under the measuring conditions mentioned above and may vary according to the actual installation situation. With any deviation from the standard set-up, the specific values have to be checked and reviewed with the unit installed.

Measured values

	Conn.	U	f	n	P <sub>e</sub>	I	LpA <sub>in</sub>	LwA <sub>in</sub>	LwA <sub>out</sub>	qv	p <sub>fs</sub>
		V	Hz	min <sup>-1</sup>	W	A	dB(A)	dB(A)	dB(A)	m <sup>3</sup> /h	Pa
1	Δ	230	60	1080	988	3.41	71	78	77	20200	0
2	Δ	230	60	1050	1171	3.89	67	74	74	17925	50
3	Δ	230	60	1025	1307	4.28	67	74	73	15860	90
4	Δ	230	60	995	1440	4.75	70	76	75	13605	130

Conn. = Connection · U = Supply voltage · f = Frequency · n = Speed · P<sub>e</sub> = Power input · I = Current draw · LpA<sub>in</sub> = Sound pressure level inlet side · LwA<sub>in</sub> = Sound power level inlet side  
LwA<sub>out</sub> = Sound power level outlet side · qv = Air flow · p<sub>fs</sub> = Pressure increase

