

A6D800-AF05-04 ebmpapst Datasheet

sales@fansco.com

www.fansco.com

Limited partnership · Headquarters Mulfingen  
County court Stuttgart · HRA 590344General partner Elektrobau Mulfingen GmbH · Headquarters Mulfingen  
County court Stuttgart · HRB 590142

## Nominal data

Type	A6D800-AF05-04				
Motor	M6D138-LA				
Phase		3~	3~	3~	3~
Nominal voltage	VAC	230	277	400	480
Connection		$\Delta$	$\Delta$	Y	Y
Frequency	Hz	50	60	50	60
Type of data definition		ml	ml	ml	ml
Valid for approval / standard		CE	CE	CE	CE
Speed	min <sup>-1</sup>	930	1095	930	1095
Power input	W	1210	1970	1210	1970
Current draw	A	5.16	6.17	2.98	3.56
Max. back pressure	Pa	160	220	160	220
Min. ambient temperature	°C	-40	-40	-40	-40
Max. ambient temperature	°C	70	60	70	60
Starting current	A	22	24	13	14

ml = max. load · me = max. efficiency · fa = running at free air · cs = customer specs · cu = customer unit  
Subject to alterations

## Data according to ErP directive

Installation category	A	Overall efficiency $\eta_{es}$	Actual	Request 2013	Request 2015
Efficiency category	Static	Efficiency grade N	38.6	29.9	33.9
Variable speed drive	No	Power input $P_e$	44.7	36	40
Specific ratio*	1.00	kW	1.1		
		Air flow $q_v$	11920		
		Pressure increase $p_{fs}$	130		
		Speed n	945		
		min <sup>-1</sup>			

Data established at point of optimum efficiency



## Technical features

Mass	24.3 kg
Size	800 mm
Surface of rotor	Cast in aluminium
Material of terminal box	PC / ABS plastic
Material of blades	Aluminium sheet insert, sprayed with PP plastic
Number of blades	5
Blade angle	-10°
Direction of air flow	"A"
Direction of rotation	Counter-clockwise, seen on rotor
Type of protection	IP 54
Insulation class	"F"
Humidity class	F3-1
Max. permissible ambient motor temp. (transp./ storage)	+ 80 °C
Min. permissible ambient motor temp. (transp./storage)	- 40 °C
Mounting position	Any
Condensate discharge holes	On rotor and stator sides
Operation mode	S1
Motor bearing	Ball bearing
Touch current acc. IEC 60990 (measuring network Fig. 4, TN system)	<= 3.5 mA
Electrical leads	Via terminal box
Motor protection	Thermal overload protector (TOP) brought out
Cable exit	Axial
Protection class	I (if protective earth is connected by customer)
Product conforming to standard	EN 60034; EN 61800-5-1; CE
Approval	GOST; UL 1004-1; CSA C22.2 Nr.100

Product drawing

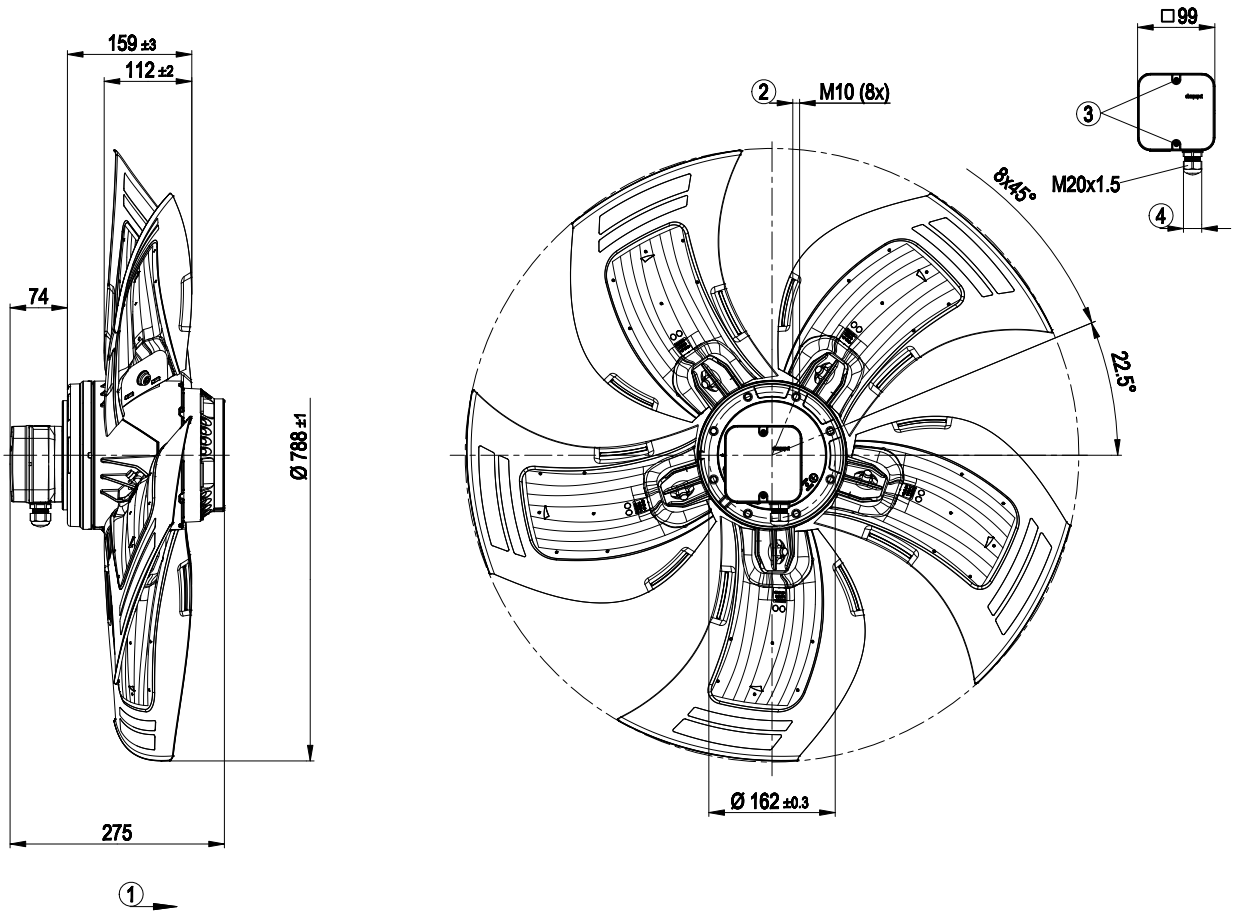

1	Direction of air flow "A"
2	Depth of screw max. 18 mm
3	Tightening torque 1.5 Nm±0.2 Nm
4	Cable diameter: min. 7 mm, max. 14 mm, tightening torque: 2±0.3 Nm

## Connection screen

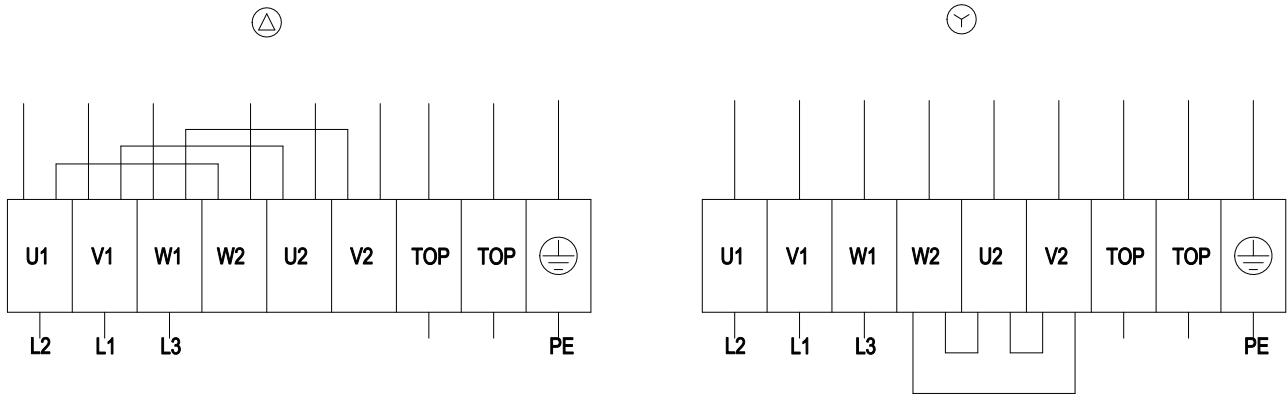

Δ	Delta connection	Y	Star connection	L1	= V1 = blue
L2	= U1 = black	L3	= W1 = brown	W2	yellow
U2	green	V2	white	TOP	2 x grey
PE	green/yellow				

## Charts: Air flow 50 Hz

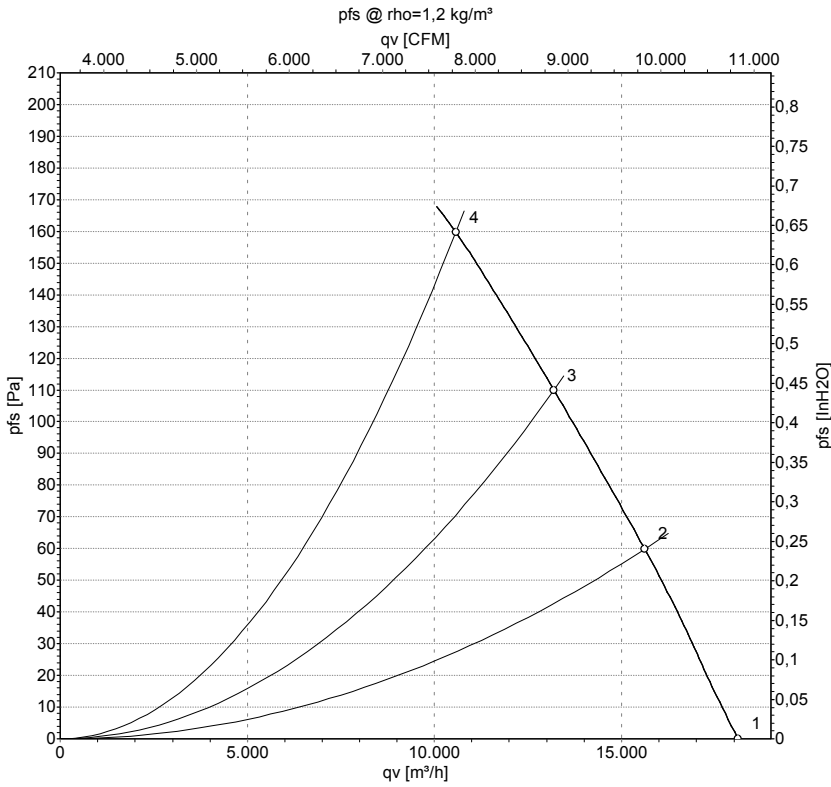

Measurement: LU-127409

Air performance measured as per ISO 5801 Installation category A. For detailed information on the measuring set-up, please contact ebm-papst. Suction-side noise levels: LwA measured as per ISO 13347 / LpA measured with 1m distance to fan axis. The values given are valid under the measuring conditions mentioned above and may vary according to the actual installation situation. With any deviation from the standard set-up, the specific values have to be checked and reviewed with the unit installed.

## Measured values

	Conn.	U	f	n	P <sub>e</sub>	I	LpA <sub>in</sub>	LwA <sub>in</sub>	LwA <sub>out</sub>	qv	p <sub>fs</sub>
		V	Hz	min <sup>-1</sup>	W	A	dB(A)	dB(A)	dB(A)	m³/h	Pa
1	Y	400	50	965	731	2.59	67	74	74	18120	0
2	Y	400	50	955	911	2.73	64	71	71	15625	60
3	Y	400	50	950	1042	2.87	67	73	72	13200	110
4	Y	400	50	930	1210	2.98	71	78	77	10575	160

Conn. = Connection · U = Supply voltage · f = Frequency · n = Speed · P<sub>e</sub> = Power input · I = Current draw · LpA<sub>in</sub> = Sound pressure level inlet side · LwA<sub>in</sub> = Sound power level inlet side  
LwA<sub>out</sub> = Sound power level outlet side · qv = Air flow · p<sub>fs</sub> = Pressure increase



## Charts: Air flow 60 Hz

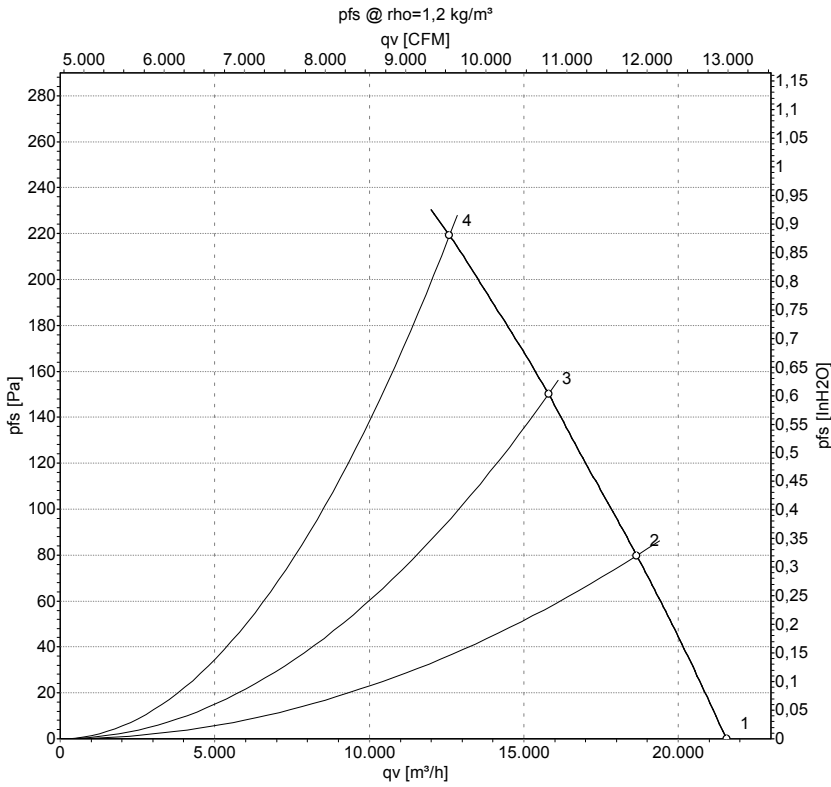

Measurement: LU-115891

Air performance measured as per ISO 5801 Installation category A. For detailed information on the measuring set-up, please contact ebm-papst. Suction-side noise levels: LwA measured as per ISO 13347 / LpA measured with 1m distance to fan axis. The values given are valid under the measuring conditions mentioned above and may vary according to the actual installation situation. With any deviation from the standard set-up, the specific values have to be checked and reviewed with the unit installed.

## Measured values

	Conn.	U	f	n	P <sub>e</sub>	I	LpA <sub>in</sub>	LwA <sub>in</sub>	LwA <sub>out</sub>	qv	p <sub>fs</sub>
		V	Hz	min <sup>-1</sup>	W	A	dB(A)	dB(A)	dB(A)	m³/h	Pa
1	Y	480	60	1145	1201	2.73	72	79	79	21560	0
2	Y	480	60	1130	1497	3.01	69	76	76	18660	80
3	Y	480	60	1115	1724	3.28	71	78	77	15800	150
4	Y	480	60	1095	1970	3.56	75	82	81	12595	220

Conn. = Connection · U = Supply voltage · f = Frequency · n = Speed · P<sub>e</sub> = Power input · I = Current draw · LpA<sub>in</sub> = Sound pressure level inlet side · LwA<sub>in</sub> = Sound power level inlet side  
 LwA<sub>out</sub> = Sound power level outlet side · qv = Air flow · p<sub>fs</sub> = Pressure increase

