

A6D710-AQ01-02 ebmpapst Datasheet

sales@fansco.com

www.fansco.com

Limited partnership · Headquarters Muldingen

Amtsgericht (court of registration) Stuttgart · HRA 590344

General partner Elektrobau Muldingen GmbH · Headquarters Muldingen

Amtsgericht (court of registration) Stuttgart · HRB 590142



Nominal data

| | | | |
|-----------------------------|--------------------|----------|------|
| Type | A6D710-AQ01-02 | | |
| Motor | M6D110-IA | | |
| Phase | | 3~ | 3~ |
| Nominal voltage | VAC | 400 | 400 |
| Wiring | | Δ | Y |
| Frequency | Hz | 50 | 50 |
| Method of obtaining data | | ml | ml |
| Valid for approval/standard | | CE | CE |
| Speed (rpm) | min ⁻¹ | 880 | 670 |
| Power consumption | W | 840 | 530 |
| Current draw | A | 1.74 | 0.94 |
| Max. back pressure | Pa | 115 | 68 |
| Max. back pressure | inH ₂ O | 0.46 | 0.27 |
| Min. ambient temperature | °C | -40 | -40 |
| Max. ambient temperature | °C | 50 | 50 |
| Starting current | A | 5 | 1.7 |

ml = Max. load · me = Max. efficiency · fa = Free air · cs = Customer specification · ce = Customer equipment
Subject to change

Data according to ErP Directive

| | | Actual | Req. 2015 |
|-----------------------------------|---|--------|-----------|
| 01 Overall efficiency η_{es} | % | 33 | 33 |
| 02 Measurement category | | A | |
| 03 Efficiency category | | Static | |
| 04 Efficiency grade N | | 40 | 40 |
| 05 Variable speed drive | | No | |

Data obtained at optimum efficiency level.

The ErP data is determined using a motor-impeller combination in a standardized measurement setup.

| | | |
|-------------------------------|-------------------|------|
| 09 Power consumption P_e | kW | 0.79 |
| 09 Air flow q_v | m ³ /h | 9505 |
| 09 Pressure increase p_{fs} | Pa | 99 |
| 10 Speed (rpm) n | min ⁻¹ | 885 |
| 11 Specific ratio* | | 1.00 |

* Specific ratio = $1 + p_{fs} / 100\,000\text{ Pa}$

LU-108461



Technical description

| | |
|--|--|
| Weight | 12.5 kg |
| Fan size | 710 mm |
| Rotor surface | Cast in aluminum |
| Terminal box material | PP plastic |
| Blade material | Sheet aluminum insert, sprayed with PP plastic |
| Number of blades | 5 |
| Blade pitch | -5° |
| Airflow direction | "A" |
| Direction of rotation | Clockwise, viewed toward rotor |
| Degree of protection | IP54 |
| Insulation class | "F" |
| Moisture (F) / Environmental (H) protection class | F3-1 |
| Max. permitted ambient temp. for motor (transport/storage) | + 80 °C |
| Min. permitted ambient temp. for motor (transport/storage) | - 40 °C |
| Installation position | Shaft horizontal or rotor on bottom; rotor on top on request |
| Condensation drainage holes | On rotor side |
| Mode | S1 |
| Motor bearing | Ball bearing |
| Touch current according to IEC 60990 (measuring circuit Fig. 4, TN system) | <= 3.5 mA |
| Electrical hookup | Via terminal box |
| Motor protection | Thermal overload protector (TOP) with basic insulation |
| With cable | Axial |
| Protection class | I (with customer connection of protective earth) |
| Conformity with standards | EN 61800-5-1; CE |
| Approval | VDE; EAC; CCC |

Product drawing

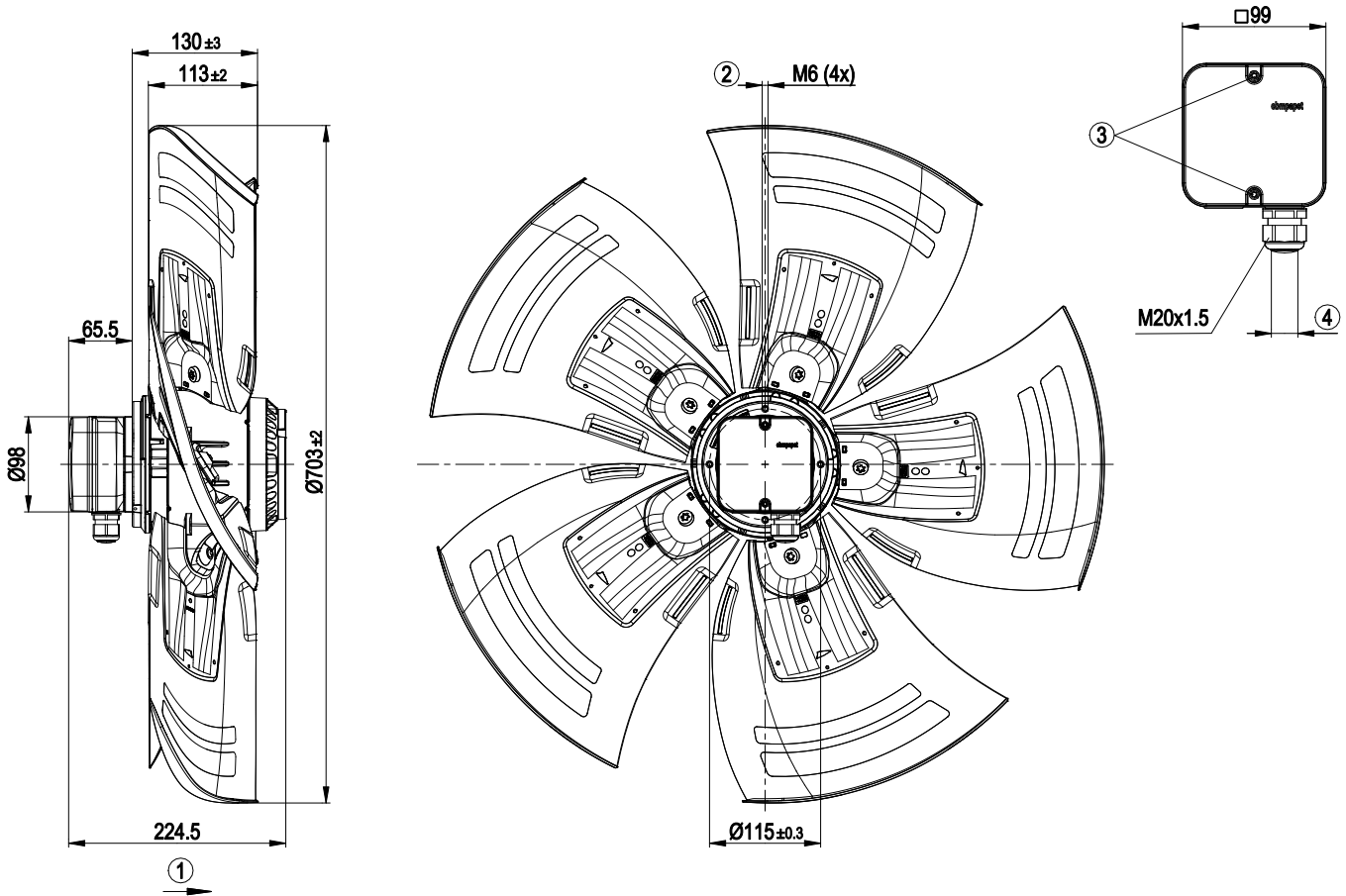

| | |
|---|---|
| 1 | Direction of air flow "A" |
| 2 | Max. clearance for screw 12 mm |
| 3 | Tightening torque 1.5 ± 0.2 Nm |
| 4 | Cable diameter: min. 7 mm, max. 14 mm; tightening torque 2±0.3 Nm |



AC axial fan - HyBlade

sickle-shaped blades (S series)

Connection diagram

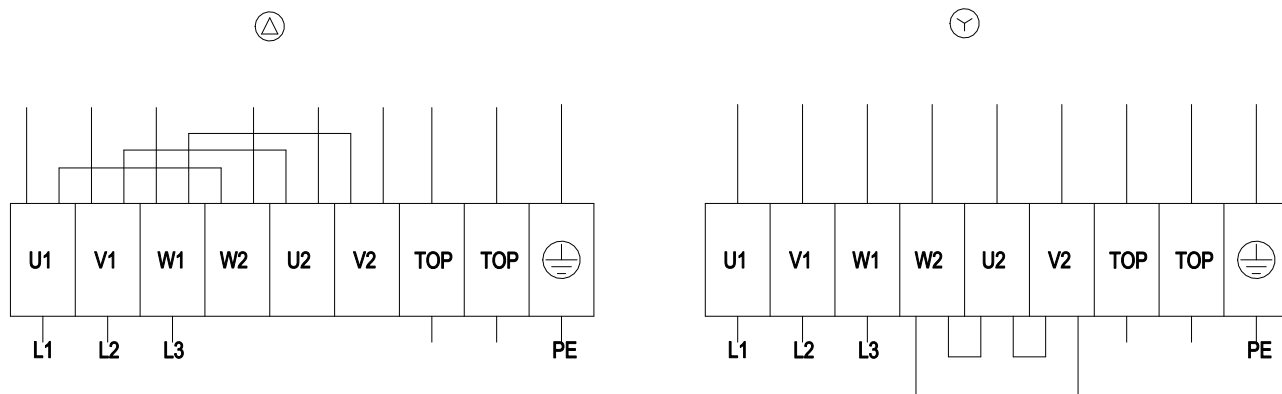

| | | | | | |
|----|------------------|----|-----------------|-----|--------------|
| Δ | Delta connection | Y | Star connection | L1 | = U1 = black |
| L2 | = V1 = blue | L3 | = W1 = brown | W2 | yellow |
| U2 | green | V2 | white | TOP | 2x gray |
| PE | green/yellow | | | | |



Curves: Air performance 50 Hz

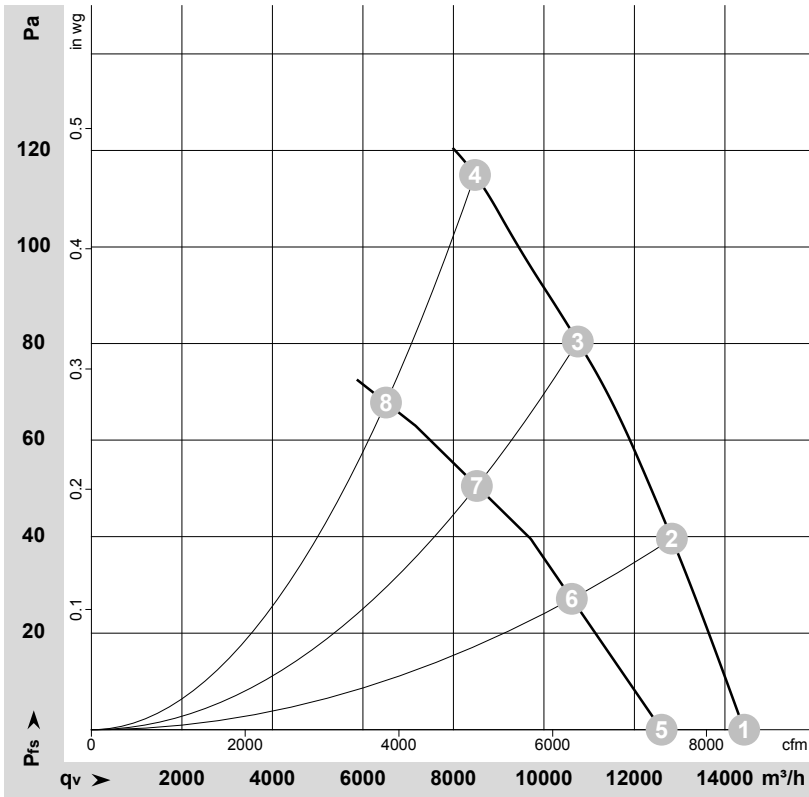

$\rho = 1.15 \text{ kg/m}^3 \pm 2 \%$

Measurement: LU-108461-1
Measurement: LU-113657-1

Air performance measured according to ISO 5801 installation category A. For detailed information on the measurement setup, contact ebmpapst. Intake sound level: Sound power level according to ISO 13347 / sound pressure level measured at 1 m distance from fan axis. The values given are valid under the specified measuring conditions and may vary due to conditions of installation. For deviations from the standard configuration, the parameters have to be checked on the installed unit.

Measured values

| | Wired | U | f | n | P _e | I | LpA _{in} | LwA _{in} | LwA _{out} | qv | p _{fs} | qv | p _{fs} |
|---|-------|-----|----|-------------------|----------------|------|-------------------|-------------------|--------------------|-------------------|-----------------|------|--------------------|
| | | V | Hz | min ⁻¹ | W | A | dB(A) | dB(A) | dB(A) | m ³ /h | Pa | CFM | inH ₂ O |
| 1 | Δ | 400 | 50 | 935 | 521 | 1.45 | 66 | 73 | 72 | 14425 | 0 | 8490 | 0.00 |
| 2 | Δ | 400 | 50 | 915 | 630 | 1.52 | 63 | 69 | 69 | 12830 | 40 | 7550 | 0.16 |
| 3 | Δ | 400 | 50 | 895 | 747 | 1.64 | 61 | 68 | 67 | 10750 | 80 | 6325 | 0.32 |
| 4 | Δ | 400 | 50 | 880 | 840 | 1.74 | 65 | 71 | 71 | 8475 | 115 | 4990 | 0.46 |
| 5 | Y | 400 | 50 | 810 | 377 | 0.69 | 63 | 69 | 69 | 12600 | 0 | 7415 | 0.00 |
| 6 | Y | 400 | 50 | 755 | 436 | 0.78 | 59 | 65 | 64 | 10615 | 27 | 6250 | 0.11 |
| 7 | Y | 400 | 50 | 705 | 487 | 0.86 | 57 | 63 | 62 | 8520 | 50 | 5015 | 0.20 |
| 8 | Y | 400 | 50 | 670 | 530 | 0.94 | 59 | 65 | 65 | 6510 | 68 | 3830 | 0.27 |

Wired = Wiring · U = Power supply · f = Frequency · n = Speed (rpm) · P_e = Power consumption · I = Current draw · LpA_{in} = Sound pressure level intake side · LwA_{in} = Sound power level intake side
LwA_{out} = Sound power level outlet side · qv = Air flow · p_{fs} = Pressure increase

