

A4S250-AI02-01 ebmpapst Datasheet

sales@fansco.com

www.fansco.com

Nominal data

Type	A4S250-AI02-01		
Motor	M4S068-CF		
Phase		1~	1~
Nominal voltage	VAC	230	230
Frequency	Hz	50	60
Method of obtaining data		fa	fa
Valid for approval/standard		CE	CE
Speed (rpm)	min ⁻¹	1390	1600
Power consumption	W	69	63
Current draw	A	0.53	0.45
Max. back pressure	Pa	80	80
Max. back pressure	in. wg	0.32	0.32
Min. ambient temperature	°C	-25	-25
Max. ambient temperature	°C	50	65
Starting current	A	0.85	0.7

ml = Max. load · me = Max. efficiency · fa = Free air · cs = Customer specification · ce = Customer equipment
 Subject to change



Technical description

Weight	1.8 kg
Fan size	250 mm
Rotor surface	Painted black
Blade material	Sheet steel, painted black
Number of blades	9
Airflow direction	"A"
Direction of rotation	Counterclockwise, viewed toward rotor
Degree of protection	IP44
Insulation class	"B"
Moisture (F) / Environmental (H) protection class	H1
Max. permitted ambient temp. for motor (transport/storage)	+ 80 °C
Min. permitted ambient temp. for motor (transport/storage)	- 40 °C
Installation position	Shaft horizontal or rotor on bottom; rotor on top on request
Condensation drainage holes	On rotor side
Mode	S1
Motor bearing	Ball bearing
Touch current according to IEC 60990 (measuring circuit Fig. 4, TN system)	< 0.75 mA
Motor protection	Thermal overload protector (TOP) internally connected
With cable	Lateral
Protection class	I (with customer connection of protective earth)
Conformity with standards	CE
Approval	EAC

AC axial fan

sickle-shaped blades (S series)

Product drawing

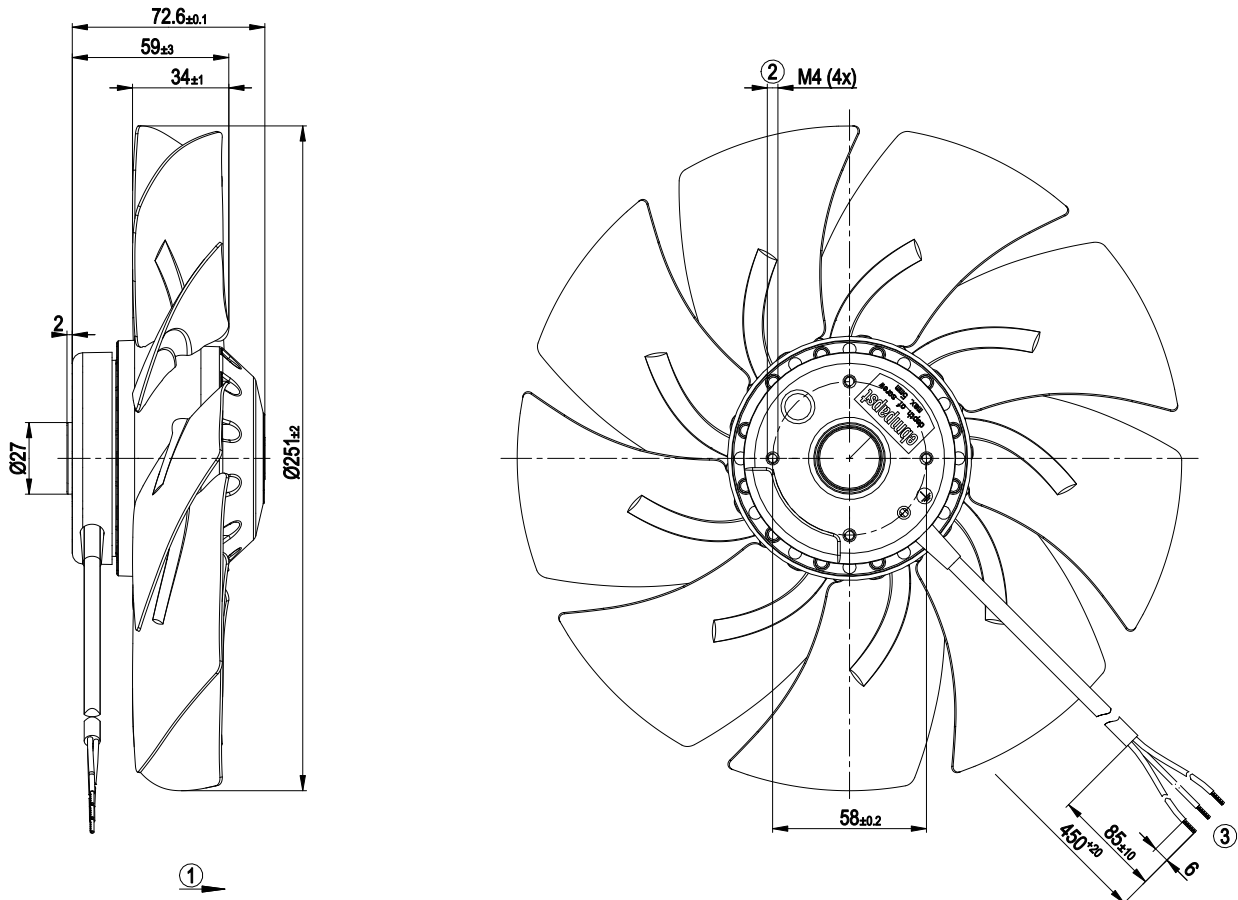

1	Direction of air flow "A"
2	Max. clearance for screw 5 mm
3	Cable PVC 3G 0.5 mm ² ; 3 x crimped splices



Connection diagram

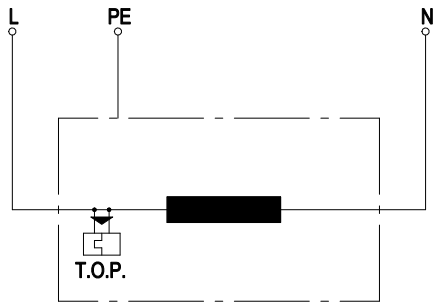

L	= blue
PE	= green/yellow
N	= black
TOP	= thermal overload protector

Curves: Air performance 50 Hz

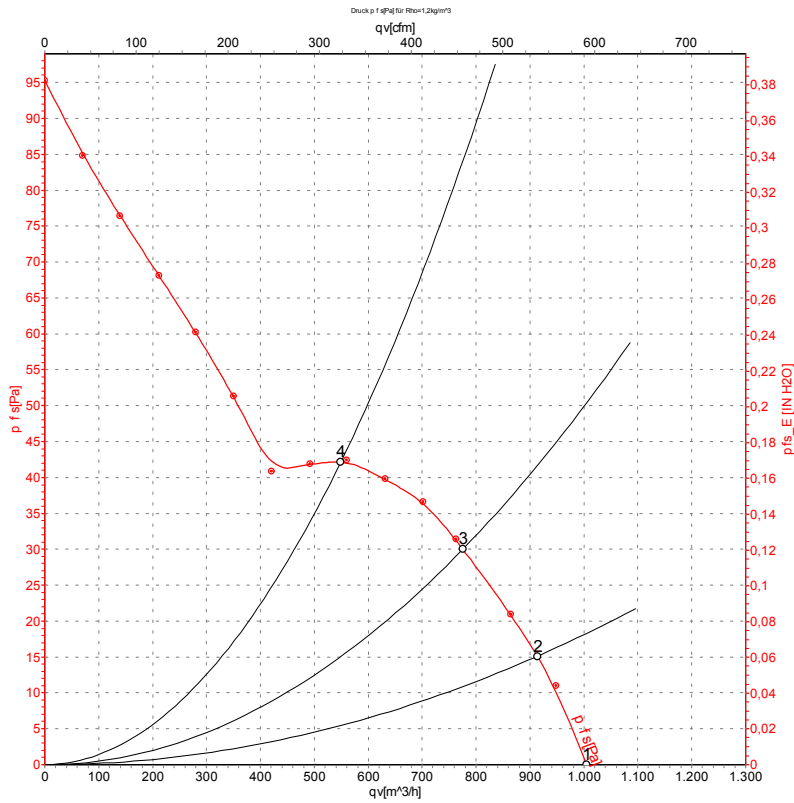

Measurement: LU-59968-1

Air performance measured according to ISO 5801 installation category A. For detailed information on the measurement setup, contact ebm-papst. Intake sound level: Sound power level according to ISO 13347 / sound pressure level measured at 1 m distance from fan axis. The values given are valid under the specified measuring conditions and may vary due to conditions of installation. For deviations from the standard configuration, the parameters have to be checked on the installed unit.

Measured values

	U	f	n	P _e	I	q _V	P _{fs}	q _V	P _{fs}
	V	Hz	min ⁻¹	W	A	m ³ /h	Pa	cfm	in. wg
1	230	50	1390	69	0.53	1005	0	590	0.00
2	230	50	1380	71	0.53	915	15	535	0.06
3	230	50	1365	73	0.53	775	30	455	0.12
4	230	50	1360	73	0.53	550	42	325	0.17

U = Power supply · f = Frequency · n = Speed (rpm) · P_e = Power consumption · I = Current draw · q_V = Air flow · P_{fs} = Pressure increase



Curves: Air performance 60 Hz

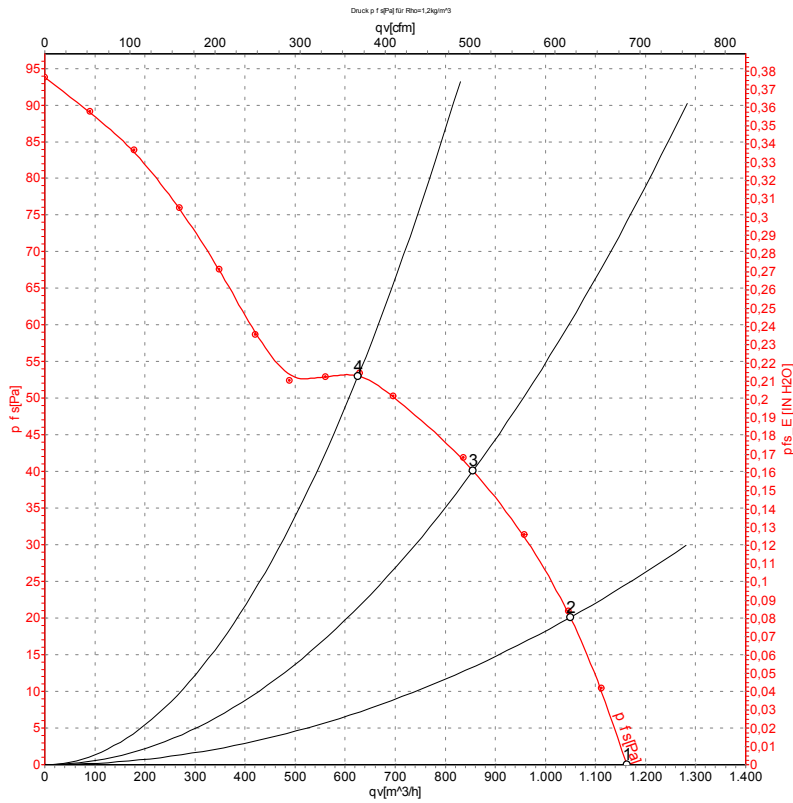

Measurement: LU-59969-1

Air performance measured according to ISO 5801 installation category A. For detailed information on the measurement setup, contact ebm-papst. Intake sound level: Sound power level according to ISO 13347 / sound pressure level measured at 1 m distance from fan axis. The values given are valid under the specified measuring conditions and may vary due to conditions of installation. For deviations from the standard configuration, the parameters have to be checked on the installed unit.

Measured values

	U	f	n	P _e	I	q _v	P _{is}	q _v	P _{is}
	V	Hz	min ⁻¹	W	A	m ³ /h	Pa	cfm	in. wg
1	230	60	1600	63	0.45	1165	0	685	0.00
2	230	60	1580	65	0.45	1050	20	620	0.08
3	230	60	1545	69	0.47	855	40	505	0.16
4	230	60	1525	71	0.48	625	53	370	0.21

U = Power supply · f = Frequency · n = Speed (rpm) · P_e = Power consumption · I = Current draw · q_v = Air flow · P_{is} = Pressure increase

