

AC axial fan

straight blades (A series)

A4S250-AA02-01 ebmpapst Datasheet
 sales@fansco.com
 www.fansco.com

Nominal data

Type	A4S250-AA02-01			
Motor	M4S068-CF			
Phase		1~	1~	1~
Nominal voltage	VAC	230	230	230
Frequency	Hz	50	60	60
Method of obtaining data		fa	fa	fa
Valid for approval/standard		CE	CE	UL
Speed (rpm)	min ⁻¹	1400	1620	1620
Power consumption	W	72	67	75
Current draw	A	0.53	0.46	0.33
Max. back pressure	Pa	80	100	100
Max. back pressure	in. wg	0.32	0.4	0.4
Min. ambient temperature	°C	-25	-25	-25
Max. ambient temperature	°C	40	50	50

ml = Max. load · me = Max. efficiency · fa = Free air · cs = Customer specification · ce = Customer equipment
 Subject to change



Technical description

Weight	1.6 kg
Size	250 mm
Motor size	68
Rotor surface	Painted black
Impeller material	Sheet steel, painted black
Number of blades	5
Airflow direction	V
Direction of rotation	Counterclockwise, viewed toward rotor
Degree of protection	IP44; installation- and position-dependent as per EN 60034-5
Insulation class	"B"
Moisture (F) / Environmental (H) protection class	H1
Max. permitted ambient temp. for motor (transport/storage)	+ 80 °C
Min. permitted ambient temp. for motor (transport/storage)	- 40 °C
Installation position	Shaft horizontal or rotor on bottom; rotor on top on request
Condensation drainage holes	On rotor side
Mode	S1
Motor bearing	Ball bearing
Touch current according to IEC 60990 (measuring circuit Fig. 4, TN system)	< 0.75 mA
Motor protection	Thermal overload protector (TOP) internally connected
With cable	Lateral
Protection class	I (with customer connection of protective earth)
Conformity with standards	EN 60335-1; CE; UKCA
Approval	EAC

Product drawing

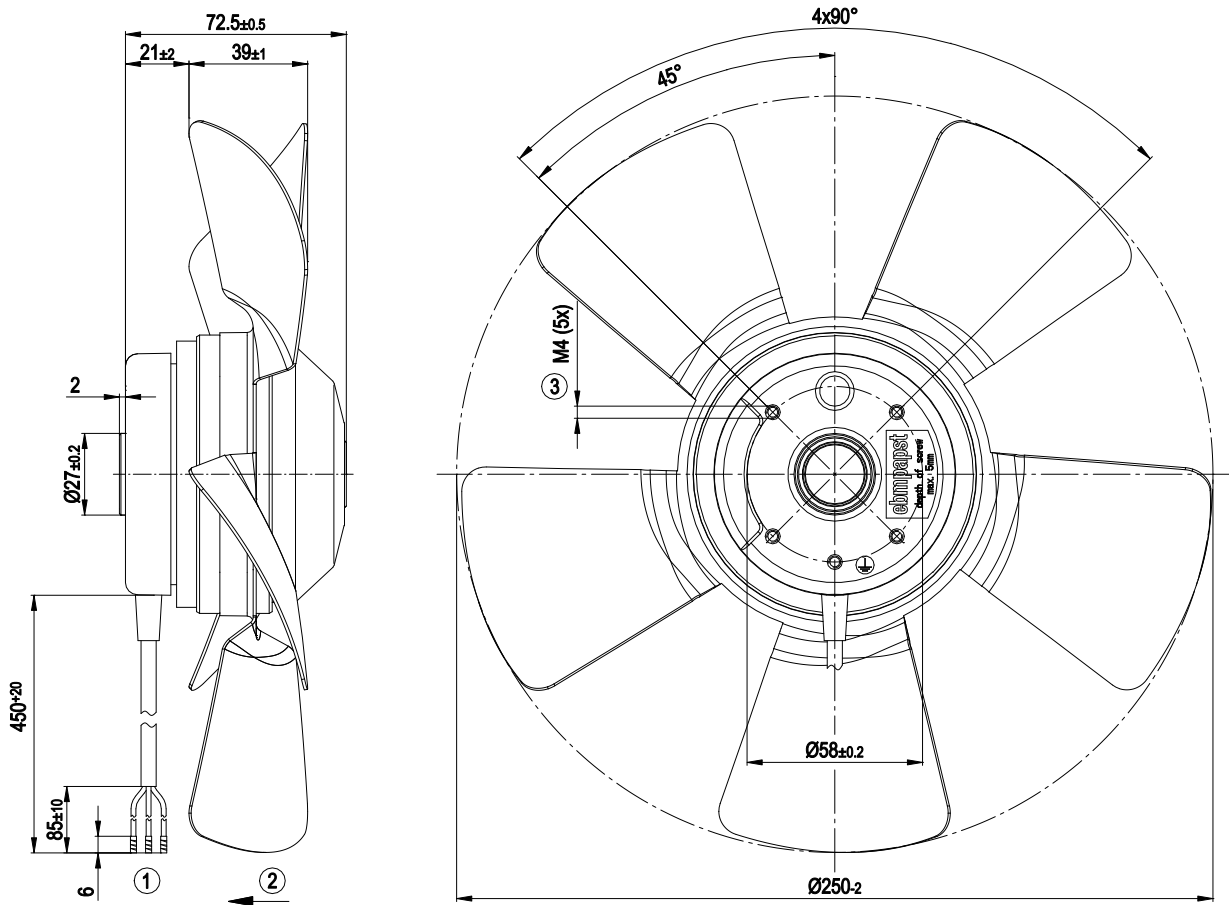

- | | |
|---|---|
| 1 | Cable PVC 3G 0.5 mm ² , 3x crimped splices |
| 2 | Direction of air flow "V" |
| 3 | Max. clearance for screw 5 mm |

Connection diagram

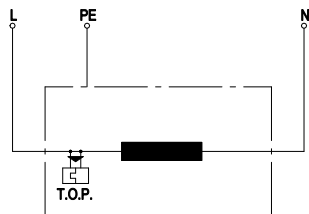

- | | |
|-----|------------------------------|
| L | = blue |
| PE | = green/yellow |
| N | = brown |
| TOP | = thermal overload protector |

Curves: Air performance 50 Hz

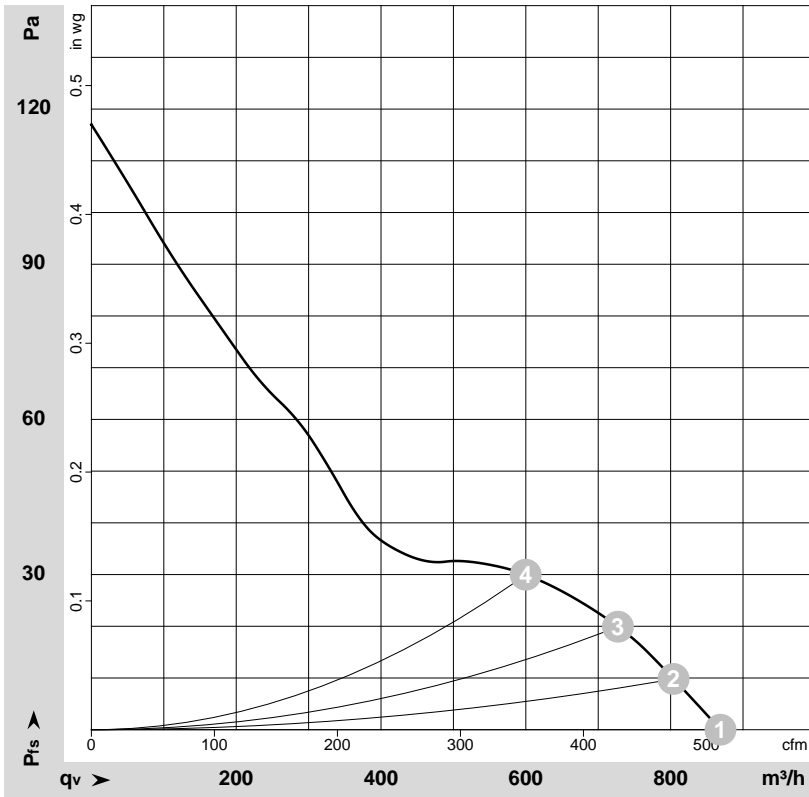

$\rho = 1.15 \text{ kg/m}^3 \pm 2 \%$

Measurement: LU-16243-1

Air performance measured according to ISO 5801 installation category A. For detailed information on the measurement setup, contact ebmpapst. Intake sound level: Sound power level according to ISO 13347 / sound pressure level measured at 1 m distance from fan axis. The values given are valid under the specified measuring conditions and may vary due to conditions of installation. For deviations from the standard configuration, the parameters have to be checked on the installed unit.

Measured values

	U	f	n	P _e	I	q _v	p _{fs}	q _v	p _{fs}
	V	Hz	min ⁻¹	W	A	m ³ /h	Pa	cfm	in. wg
1	230	50	1400	72	0.53	870	0	510	0.00
2	230	50	1400	70	0.52	805	10	475	0.04
3	230	50	1400	70	0.52	725	20	430	0.08
4	230	50	1390	70	0.52	600	30	355	0.12

U = Voltage · f = Frequency · n = Speed (rpm) · P_e = Power consumption · I = Current draw · q_v = Air flow · p_{fs} = Pressure increase



Curves: Air performance 60 Hz

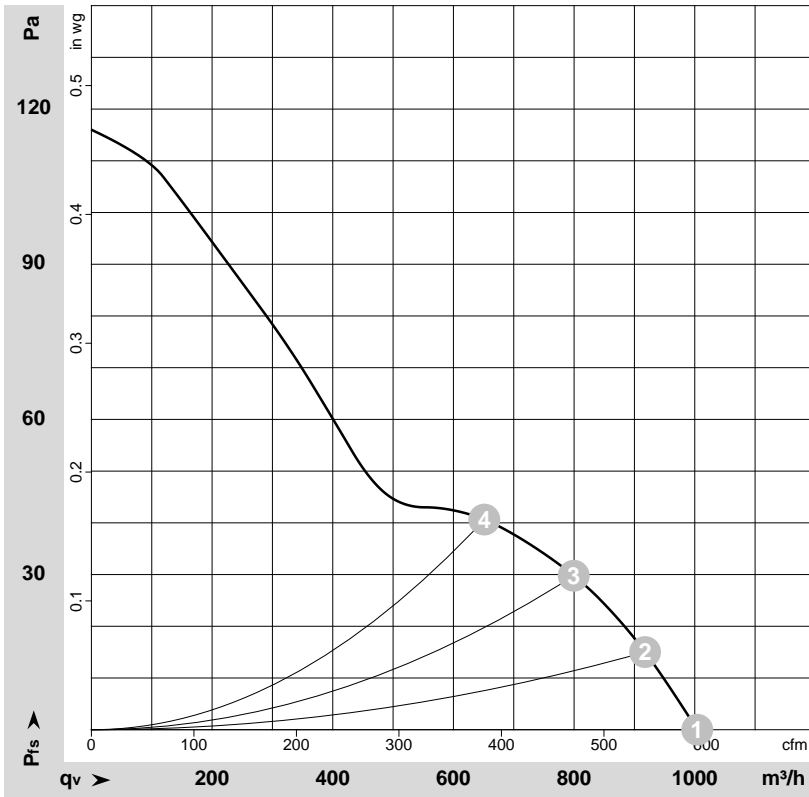

$\rho = 1.15 \text{ kg/m}^3 \pm 2 \%$

Measurement: LU-16244-1

Air performance measured according to ISO 5801 installation category A. For detailed information on the measurement setup, contact ebmpapst. Intake sound level: Sound power level according to ISO 13347 / sound pressure level measured at 1 m distance from fan axis. The values given are valid under the specified measuring conditions and may vary due to conditions of installation. For deviations from the standard configuration, the parameters have to be checked on the installed unit.

Measured values

	U	f	n	P _e	I	q _v	p _{fs}	q _v	p _{fs}
	V	Hz	min ⁻¹	W	A	m ³ /h	Pa	cfm	in. wg
1	230	60	1620	67	0.46	1005	0	590	0.00
2	230	60	1610	66	0.45	920	15	540	0.06
3	230	60	1605	67	0.46	800	30	470	0.12
4	230	60	1600	67	0.46	650	40	385	0.16

U = Voltage · f = Frequency · n = Speed (rpm) · P_e = Power consumption · I = Current draw · q_v = Air flow · p_{fs} = Pressure increase

