

A4E500-AE03-01 ebmpapst Datasheet

sales@fansco.com

www.fansco.com

Nominal data

Type	A4E500-AE03-01		
Motor	M4E110-GF		
Phase		1~	1~
Nominal voltage	VAC	230	230
Frequency	Hz	50	60
Method of obtaining data		ml	ml
Valid for approval/standard		CE	CE
Speed (rpm)	min ⁻¹	1310	1420
Power consumption	W	680	890
Current draw	A	3.0	3.92
Capacitor	μF	12	12
Capacitor voltage	VDB	450	450
Capacitor standard		S0 (CE)	S0 (CE)
Max. back pressure	Pa	160	120
Max. back pressure	in. wg	0.64	0.48
Min. ambient temperature	°C	-40	-40
Max. ambient temperature	°C	70	60
Starting current	A	6.65	6.0

ml = Max. load · me = Max. efficiency · fa = Free air · cs = Customer specification · ce = Customer equipment
Subject to change

Data according to Commission Regulation (EU) 327/2011 (EN 17166)

		Actual	Req. 2015			
01 Overall efficiency η_{es}	%	32.5	32.4	09 Power consumption P_e	kW	0.63
02 Measurement category		A		09 Air flow q_v	m ³ /h	5915
03 Efficiency category		Static		09 Pressure increase p_{fs}	Pa	127
04 Efficiency grade N		40.1	40	10 Speed (rpm) n	min ⁻¹	1345
05 Variable speed drive		No		11 Specific ratio*		1.00

Data obtained at optimum efficiency level.

The ErP data is determined using a motor-impeller combination in a standardized measurement setup.

* Specific ratio = $1 + p_g / 100\,000\text{ Pa}$

LU-207280



Technical description

Weight	10.3 kg
Size	500 mm
Motor size	110
Rotor surface	Cast in aluminum
Terminal box material	PP plastic
Blade material	Sheet aluminum
Number of blades	5
Blade pitch	-5°
Airflow direction	V
Direction of rotation	Counterclockwise, viewed toward rotor
Degree of protection	IP54
Insulation class	"F"
Moisture (F) / Environmental (H) protection class	H2
Max. permitted ambient temp. for motor (transport/storage)	+80 °C
Min. permitted ambient temp. for motor (transport/storage)	-40 °C
Installation position	Shaft horizontal or rotor on bottom; rotor on top on request
Condensation drainage holes	On rotor side
Mode	S1
Motor bearing	Ball bearing
Touch current according to IEC 60990 (measuring circuit Fig. 4, TN system)	<= 3.5 mA
Electrical hookup	Terminal box
Motor protection	Thermal overload protector (TOP) with basic insulation
With cable	Axial
Protection class	I (with customer connection of protective earth)
Motor capacitor according to EN 60252-1 in safety protection class	S0
Conformity with standards	EN 60034-1; CE
Approval	UL 1004-1; EAC; CSA C22.2 No. 100; VDE

Product drawing

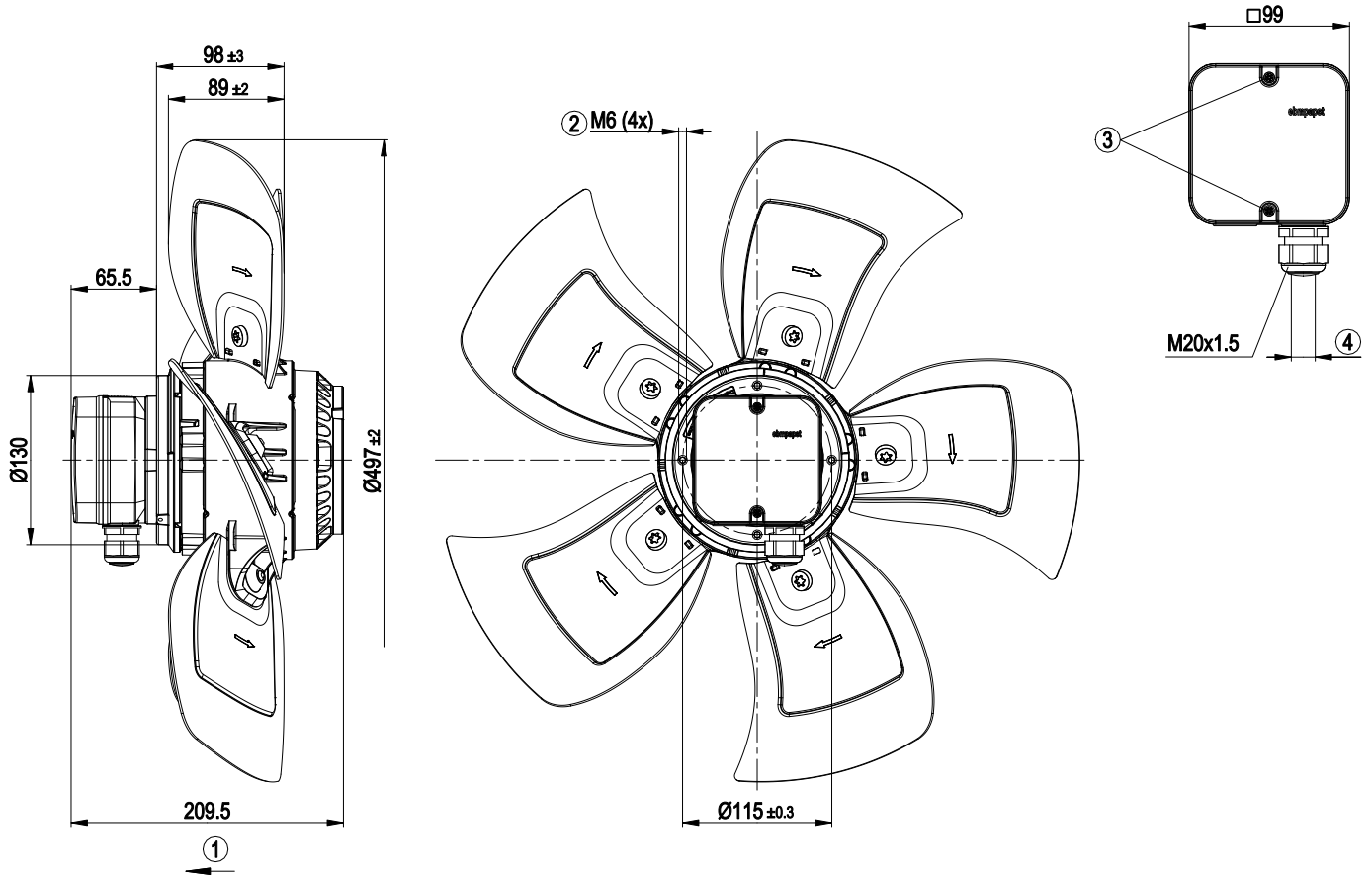

1	Direction of air flow "V"
2	Max. clearance for screw 12 mm
3	Tightening torque 1.5 ± 0.2 Nm
4	Cable diameter min. 6 mm, max. 12 mm, tightening torque 2.0 ± 0.3 Nm

Connection diagram

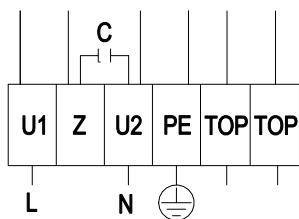

L	= U1 = blue	Z	brown	N	= U2 = black
PE	green/yellow	TOP	gray		



Curves: Air performance 50 Hz

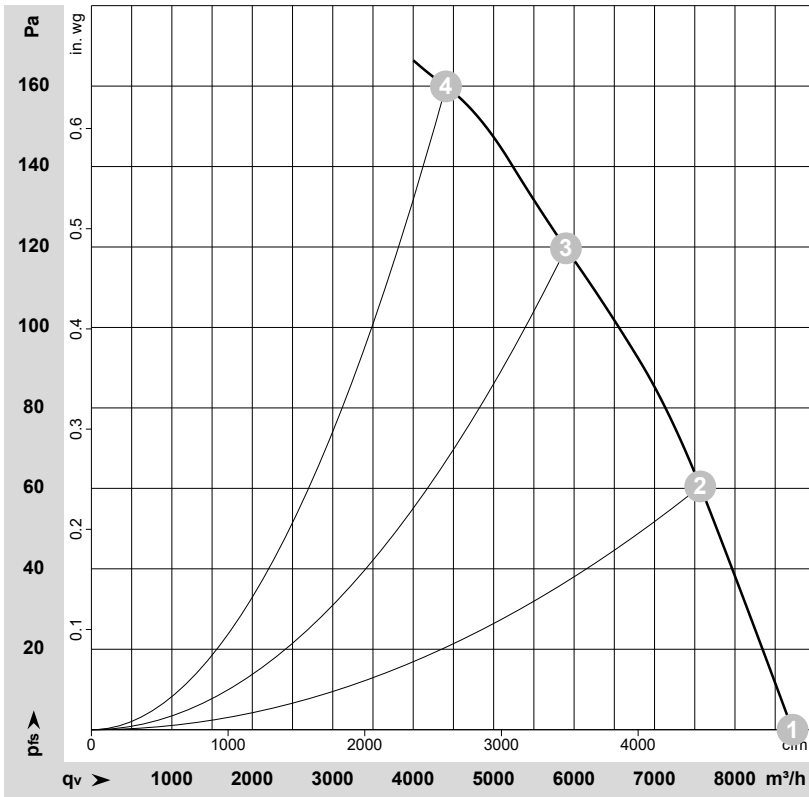

$\rho = 1.15 \text{ kg/m}^3 \pm 2 \%$

Measurement: LU-145085-1

Air performance measured according to ISO 5801 installation category A. For detailed information on the measurement setup, contact ebm-papst. Intake sound level: Sound power level according to ISO 13347 / sound pressure level measured at 1 m distance from fan axis. The values given are valid under the specified measuring conditions and may vary due to conditions of installation. For deviations from the standard configuration, the parameters have to be checked on the installed unit.

Measured values

	Wired	U	f	n	P _e	I	q _v	P _{fs}	q _v	P _{fs}
		V	Hz	min ⁻¹	W	A	m ³ /h	Pa	cfm	in. wg
1	1~	230	50	1390	508	2.22	8715	0	5130	0.00
2	1~	230	50	1365	569	2.49	7570	60	4455	0.24
3	1~	230	50	1340	626	2.75	5900	120	3470	0.48
4	1~	230	50	1310	680	3.00	4405	160	2595	0.64

Wired = Wiring · U = Voltage · f = Frequency · n = Speed (rpm) · P_e = Power consumption · I = Current draw · q_v = Air flow · P_{fs} = Pressure increase



Curves: Air performance 60 Hz

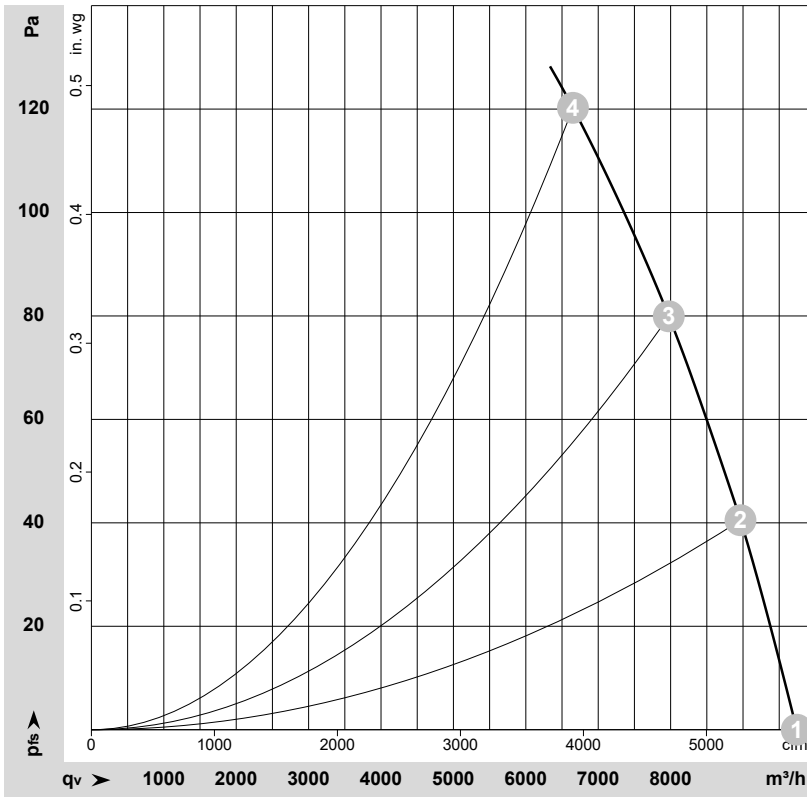

$\rho = 1.15 \text{ kg/m}^3 \pm 2 \%$

Measurement: LU-145095-1

Air performance measured according to ISO 5801 installation category A. For detailed information on the measurement setup, contact ebmpapst. Intake sound level: Sound power level according to ISO 13347 / sound pressure level measured at 1 m distance from fan axis. The values given are valid under the specified measuring conditions and may vary due to conditions of installation. For deviations from the standard configuration, the parameters have to be checked on the installed unit.

Measured values

	Wired	U	f	n	P _e	I	q _v	p _{fs}	q _v	p _{fs}
		V	Hz	min ⁻¹	W	A	m ³ /h	Pa	cfm	in. wg
1	1~	230	60	1560	785	3.40	9740	0	5735	0.00
2	1~	230	60	1520	819	3.56	8965	40	5275	0.16
3	1~	230	60	1470	862	3.76	7975	80	4695	0.32
4	1~	230	60	1420	890	3.92	6650	120	3915	0.48

Wired = Wiring · U = Voltage · f = Frequency · n = Speed (rpm) · P_e = Power consumption · I = Current draw · q_v = Air flow · p_{fs} = Pressure increase

