

A4E450-AV01-61 ebmpapst Datasheet
 sales@fansco.com
 www.fansco.com

Limited partnership · Headquarters Mulfingen
 County court Stuttgart · HRA 590344

General partner Elektrobau Mulfingen GmbH · Headquarters Mulfingen
 County court Stuttgart · HRB 590142



Nominal data

Type	A4E450-AV01-61		
Motor	M4E094-HA		
Phase		1~	1~
Nominal voltage	VAC	230	230
Frequency	Hz	50	60
Type of data definition		ml	ml
Valid for approval / standard		CE	CE
Speed	min ⁻¹	1380	1560
Power input	W	375	555
Current draw	A	1.8	2.43
Motor capacitor	µF	10	10
Capacitor voltage	VDB	400	400
Max. back pressure	Pa	130	120
Max. ambient temperature	°C	70	55

ml = max. load · me = max. efficiency · fa = running at free air · cs = customer specs · cu = customer unit
 Subject to alterations

Data according to ErP directive

		Actual	Request 2013	Request 2015
Installation category	A			
Efficiency category	Static			
Variable speed drive	No			
Specific ratio [*]	1.00			
Overall efficiency η_{es}		31.5	27.5	31.5
Efficiency grade N		40	36	40
Power input P_e	kW	0.46		
Air flow q_v	m ³ /h	4305		
Pressure increase p_{fs}	Pa	120		
Speed n	min ⁻¹	1335		

Data established at point of optimum efficiency

^{*} Specific ratio = $1 + p_b / 100\,000\text{ Pa}$



Technical features

Mass	7.9 kg
Size	450 mm
Surface of rotor	Coated in black
Material of terminal box	ABS plastic, black
Material of blades	Sheet steel, coated in black
Number of blades	5
Direction of air flow	"V"
Direction of rotation	Counter-clockwise, seen on rotor
Type of protection	IP 54
Insulation class	"F"
Humidity class	F3-1
Max. permissible ambient motor temp. (transp./ storage)	+ 80 °C
Min. permissible ambient motor temp. (transp./storage)	- 40 °C
Mounting position	Any
Condensate discharge holes	None
Operation mode	S1
Motor bearing	Ball bearing
Touch current acc. IEC 60990 (measuring network Fig. 4, TN system)	<= 3.5 mA
Electrical leads	Via terminal box, integrated capacitor connected via terminal box
Motor protection	Thermal overload protector (TOP) brought out
Protection class	I (if protective earth is connected by customer)
Product conforming to standard	EN 60034-1 (2004); CE

Product drawing

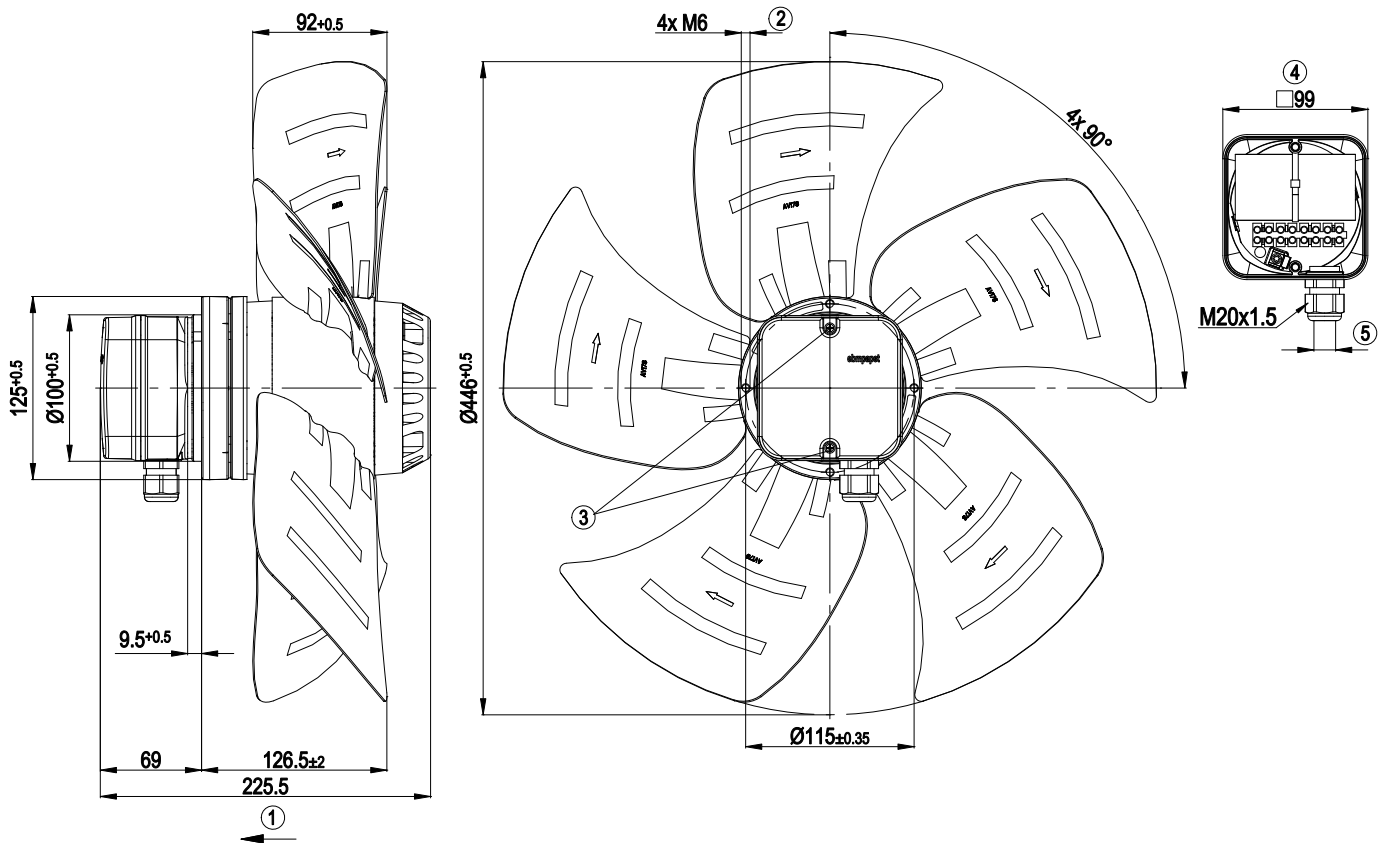

1	Direction of air flow V
2	Depth of screw max. 10 mm
3	Tightening torque 1.5 Nm \pm 0.2 Nm
4	Shown without terminal box cover
5	Cable diameter: min. 6 mm, max. 12 mm; tightening torque: 2 Nm \pm 0.3 Nm

Connection screen

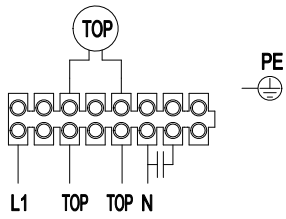

L1	black
TOP	Thermal overload protector (2x grey)
N	white
PE	green/yellow



Charts: Air flow 50 Hz

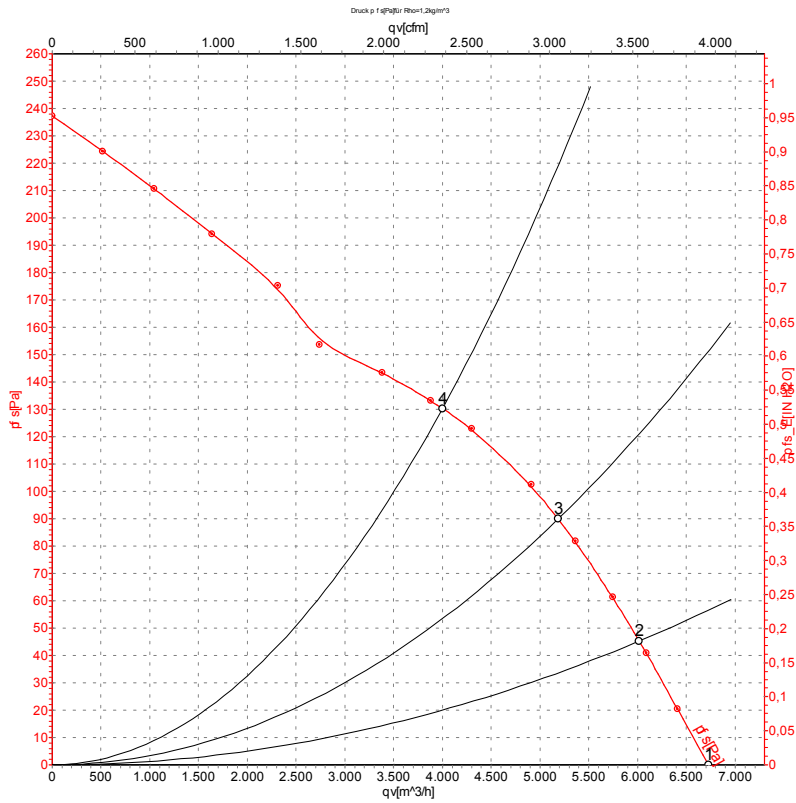

Measurement: LU-41800

Air performance measured as per ISO 5801 Installation category A. For detailed information on the measuring set-up, please contact ebm-papst. Suction-side noise levels: L_{wA} measured as per ISO 13347 / L_{pA} measured with 1m distance to fan axis. The values given are valid under the measuring conditions mentioned above and may vary according to the actual installation situation. With any deviation from the standard set-up, the specific values have to be checked and reviewed with the unit installed.

Measured values

	U	f	n	P _e	I	qv	p _{fs}
	V	Hz	min ⁻¹	W	A	m ³ /h	Pa
1	230	50	1380	375	1.80	6725	0
2	230	50	1370	410	1.95	6015	45
3	230	50	1350	446	2.10	5185	90
4	230	50	1330	479	2.25	4000	130

U = Supply voltage · f = Frequency · n = Speed · P_e = Power input · I = Current draw · qv = Air flow · p_{fs} = Pressure increase



Charts: Air flow 60 Hz

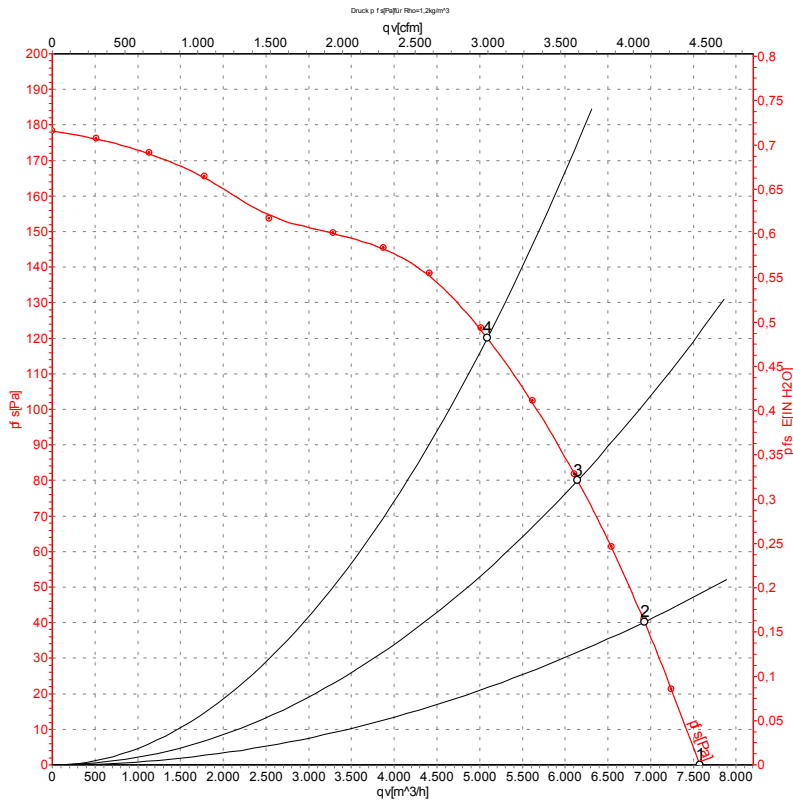

Measurement: LU-41801

Air performance measured as per ISO 5801 Installation category A. For detailed information on the measuring set-up, please contact ebm-papst. Suction-side noise levels: L_{wA} measured as per ISO 13347 / L_{pA} measured with 1m distance to fan axis. The values given are valid under the measuring conditions mentioned above and may vary according to the actual installation situation. With any deviation from the standard set-up, the specific values have to be checked and reviewed with the unit installed.

Measured values

	U	f	n	P _e	I	qv	P _{fs}
	V	Hz	min ⁻¹	W	A	m ³ /h	Pa
1	230	60	1560	555	2.43	7575	0
2	230	60	1525	584	2.57	6925	40
3	230	60	1485	615	2.73	6145	80
4	230	60	1425	648	2.91	5090	120

U = Supply voltage · f = Frequency · n = Speed · P_e = Power input · I = Current draw · qv = Air flow · P_{fs} = Pressure increase

