

A4E450-AQ05-09 ebmpapst Datasheet

sales@fansco.com

www.fansco.com

Limited partnership · Headquarters Mulfingen

Amtsgericht (court of registration) Stuttgart · HRA 590344

General partner Elektrobau Mulfingen GmbH · Headquarters Mulfingen

Amtsgericht (court of registration) Stuttgart · HRB 590142

Nominal data

Type	A4E450-AQ05-09	
Motor	M4E074-EI	
Phase		1~
Nominal voltage	VAC	230
Frequency	Hz	50
Method of obtaining data		fa
Valid for approval/standard		CE
Speed (rpm)	min ⁻¹	1350
Power consumption	W	225
Current draw	A	1.0
Capacitor	µF	6
Capacitor voltage	VDB	400
Capacitor standard		S0 (CE)
Max. back pressure	Pa	60
Max. back pressure	inH ₂ O	0.24
Min. ambient temperature	°C	-25
Max. ambient temperature	°C	60
Starting current	A	2.05

ml = Max. load · me = Max. efficiency · fa = Free air · cs = Customer specification · ce = Customer equipment
Subject to change

Data according to ErP Directive

		Actual	Req. 2015			
01 Overall efficiency η_{es}	%	31.7	30.1	09 Power consumption P_e	kW	0.27
02 Measurement category		A		09 Air flow q_v	m ³ /h	3510
03 Efficiency category		Static		09 Pressure increase p_{fs}	Pa	90
04 Efficiency grade N		41.6	40	10 Speed (rpm) n	min ⁻¹	1260
05 Variable speed drive		No		11 Specific ratio*		1.00

Data obtained at optimum efficiency level.

The ErP data is determined using a motor-impeller combination in a standardized measurement setup.

* Specific ratio = $1 + p_g / 100\,000\text{ Pa}$

LU-115158



Technical description

Weight	4.4 kg
Fan size	450 mm
Rotor surface	Painted black
Blade material	Sheet steel, painted black
Number of blades	5
Airflow direction	"V"
Direction of rotation	Counterclockwise, viewed toward rotor
Degree of protection	IP44; installation- and position-dependent as per EN 60034-5. The degree of protection is only assured when the intended cable guard and terminal box are installed.
Insulation class	"F"
Moisture (F) / Environmental (H) protection class	H0+
Max. permitted ambient temp. for motor (transport/storage)	+ 80 °C
Min. permitted ambient temp. for motor (transport/storage)	- 40 °C
Installation position	Shaft horizontal or rotor on bottom; rotor on top on request
Condensation drainage holes	On rotor side
Mode	S1
Motor bearing	Ball bearing
Touch current according to IEC 60990 (measuring circuit Fig. 4, TN system)	< 0.75 mA
Electrical hookup	Prepared for terminal box installation
Motor protection	Thermal overload protector (TOP) internally connected
With cable	Variable
Protection class	I (with customer connection of protective earth)
Conformity with standards	CE

AC axial fan

sickle-shaped blades (S series)

Product drawing

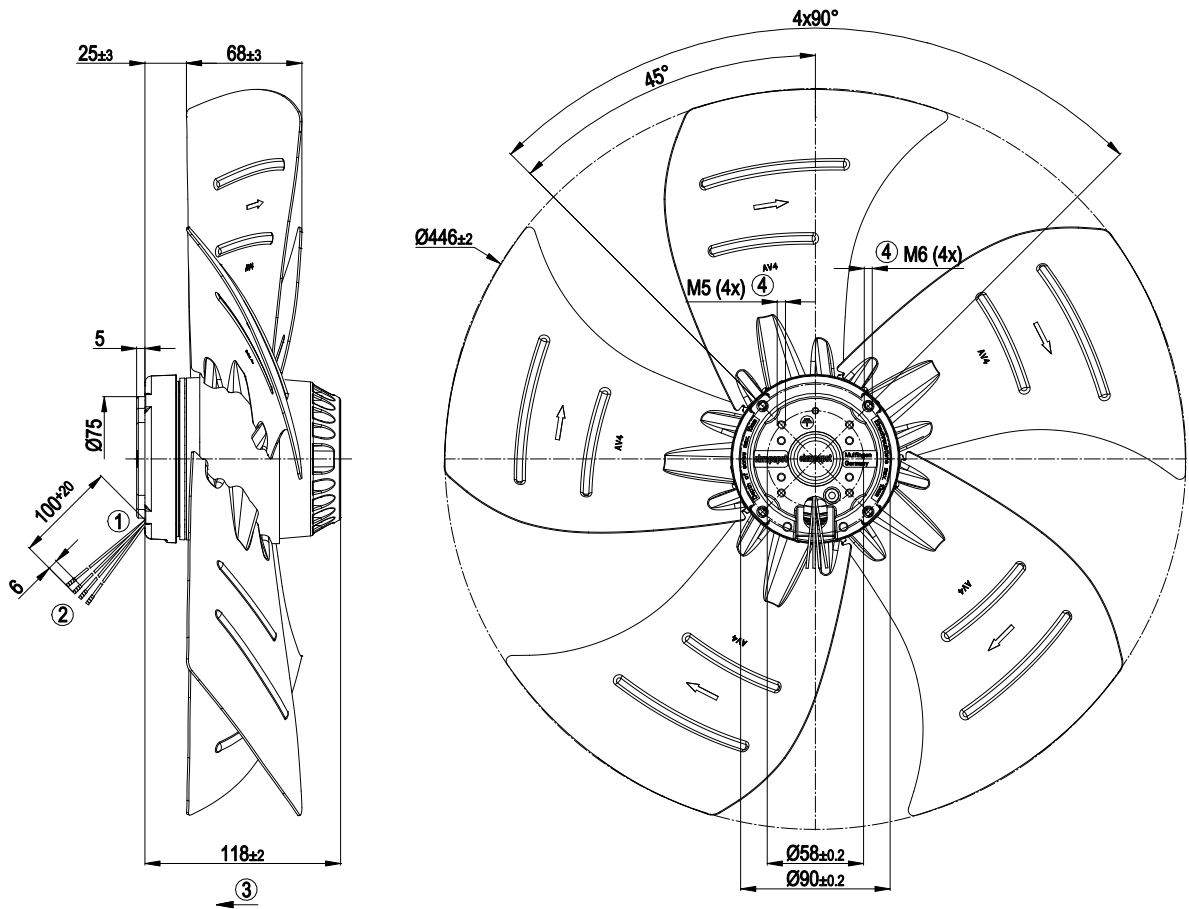

- | | |
|---|---|
| 1 | Accessory part: Terminal box 64443-1-7612 not included in scope of delivery |
| 2 | Cable halogen-silicone-free 4G 0.5 mm ² , 4x crimped splices |
| 3 | Direction of air flow "V" |
| 4 | Max. clearance for screw 10 mm |



Connection diagram

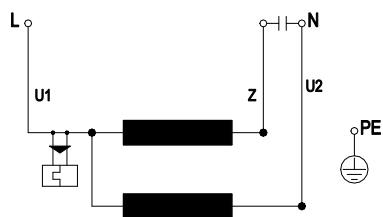

U1	blue	Z	brown	U2	black
PE	green/yellow				

Curves: Air performance 50 Hz

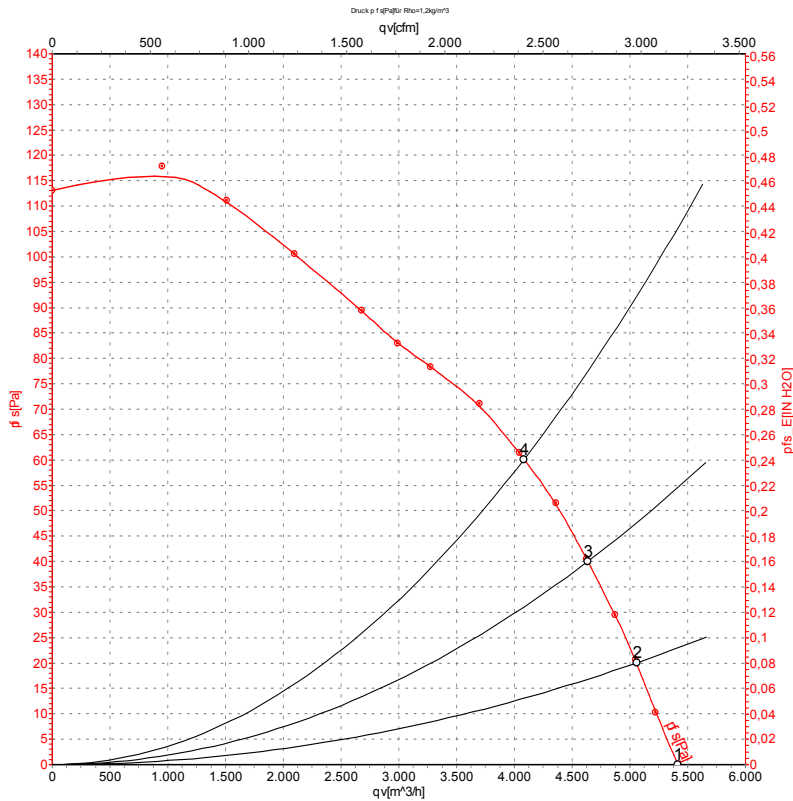

Measurement: LU-34432-1

Air performance measured according to ISO 5801 installation category A. For detailed information on the measurement setup, contact ebm-papst. Intake sound level: Sound power level according to ISO 13347 / sound pressure level measured at 1 m distance from fan axis. The values given are valid under the specified measuring conditions and may vary due to conditions of installation. For deviations from the standard configuration, the parameters have to be checked on the installed unit.

Measured values

	U	f	n	P _e	I	q _v	P _{fs}	q _v	P _{fs}
	V	Hz	min ⁻¹	W	A	m ³ /h	Pa	cfm	inH ₂ O
1	230	50	1350	225	1.00	5415	0	3185	0.00
2	230	50	1320	242	1.07	5055	20	2975	0.08
3	230	50	1290	256	1.13	4635	40	2730	0.16
4	230	50	1260	275	1.21	4085	60	2405	0.24

U = Power supply · f = Frequency · n = Speed (rpm) · P_e = Power consumption · I = Current draw · q_v = Air flow · P_{fs} = Pressure increase

