

A4E450-AO09-09 ebmpapst Datasheet

sales@fansco.com

www.fansco.com

Limited partnership · Headquarters Mulfingen

Amtsgericht (court of registration) Stuttgart · HRA 590344

General partner Elektrobau Mulfingen GmbH · Headquarters Mulfingen

Amtsgericht (court of registration) Stuttgart · HRB 590142



## Nominal data

Type	A4E450-AO09-09		
Motor	M4E094-HA		
Phase		1~	1~
Nominal voltage	VAC	230	230
Frequency	Hz	50	60
Method of obtaining data		ml	ml
Valid for approval/standard		CE	CE
Speed (rpm)	min <sup>-1</sup>	1310	1390
Power consumption	W	490	650
Current draw	A	2.36	2.96
Capacitor	µF	10	10
Capacitor voltage	VDB	400	400
Max. back pressure	Pa	125	115
Max. back pressure	inH <sub>2</sub> O	0.5	0.46
Min. ambient temperature	°C	-40	-40
Max. ambient temperature	°C	65	55

ml = Max. load · me = Max. efficiency · fa = Free air · cs = Customer specification · ce = Customer equipment  
Subject to change

## Data according to ErP Directive

	Actual	Req. 2015				
01 Overall efficiency $\eta_{es}$	%	31.7	31.7	09 Power consumption $P_e$	kW	0.48
02 Measurement category	A			09 Air flow $q_v$	m <sup>3</sup> /h	4420
03 Efficiency category	Static			09 Pressure increase $p_{fs}$	Pa	122
04 Efficiency grade N	40	40		10 Speed (rpm) n	min <sup>-1</sup>	1315
05 Variable speed drive	No			11 Specific ratio*		1.00

Data obtained at optimum efficiency level.  
The ErP data is determined using a motor-impeller combination in a standardized measurement setup.

\* Specific ratio =  $1 + p_{fs} / 100\,000\text{ Pa}$

LU-106846



## Technical description

Weight	7.3 kg
Fan size	450 mm
Rotor surface	Painted black
Blade material	Press-fitted sheet steel blank, sprayed with PP plastic
Number of blades	5
Airflow direction	"V"
Direction of rotation	Counterclockwise, viewed toward rotor
Degree of protection	IP54
Insulation class	"F"
Moisture (F) / Environmental (H) protection class	F4-1
Max. permitted ambient temp. for motor (transport/storage)	+80 °C
Min. permitted ambient temp. for motor (transport/storage)	-40 °C
Installation position	Shaft horizontal or rotor on bottom; rotor on top on request
Condensation drainage holes	On rotor side
Mode	S1
Motor bearing	Ball bearing
Touch current according to IEC 60990 (measuring circuit Fig. 4, TN system)	<= 3.5 mA
Motor protection	Thermal overload protector (TOP) with basic insulation
With cable	Variable
Protection class	I (with customer connection of protective earth)
Conformity with standards	EN 60034-1 (2004); CE

Product drawing

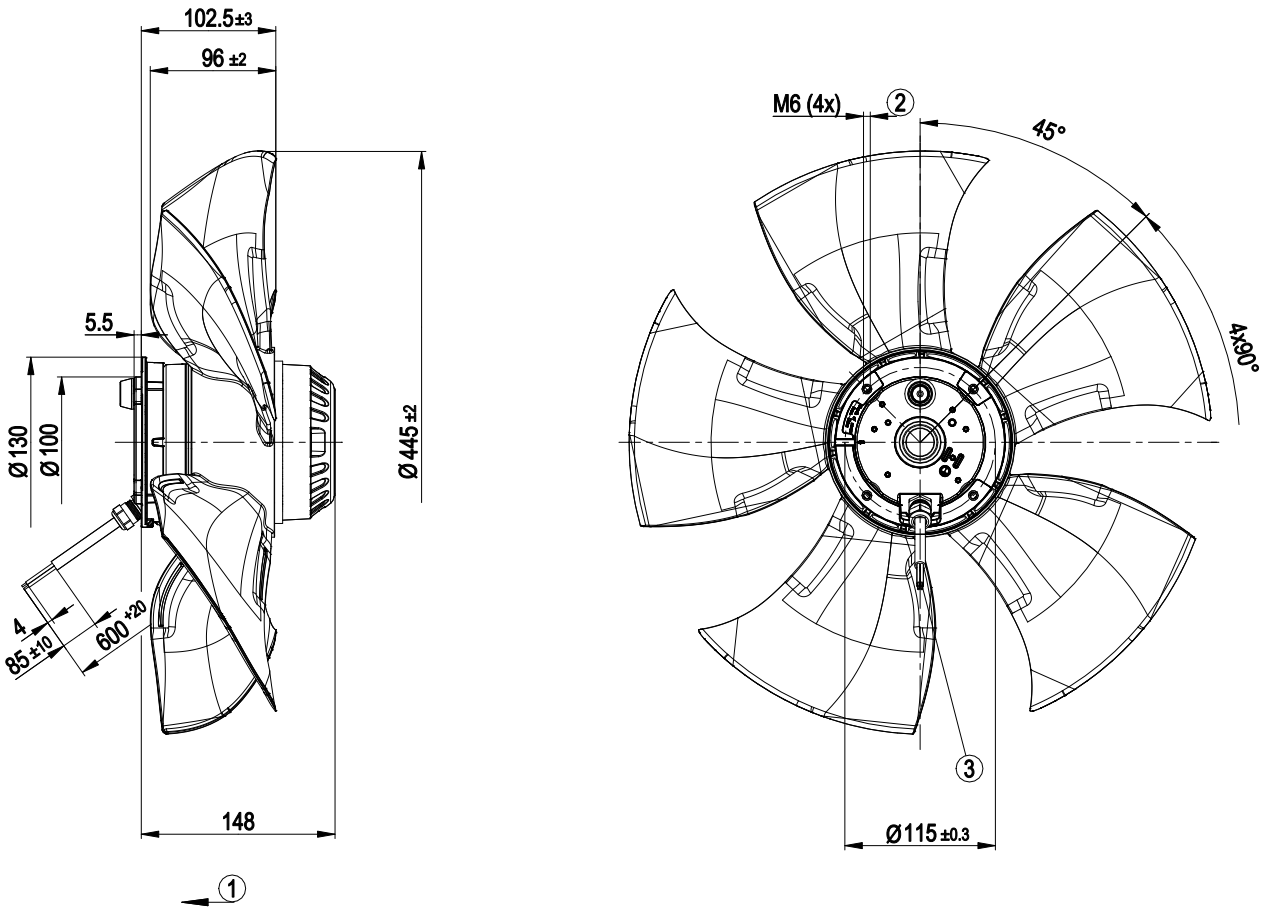

1	Direction of air flow "V"
2	Max. clearance for screw 12 mm
3	Cable silicone 6G0.5, 6 x crimped splices



## Connection diagram

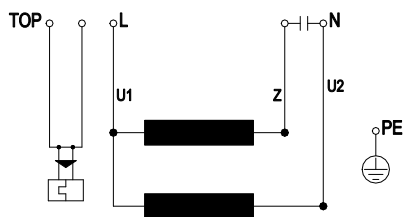

TOP	2x gray	U1	blue	Z	brown
U2	black	PE	green/yellow		

## Curves: Air performance 50 Hz

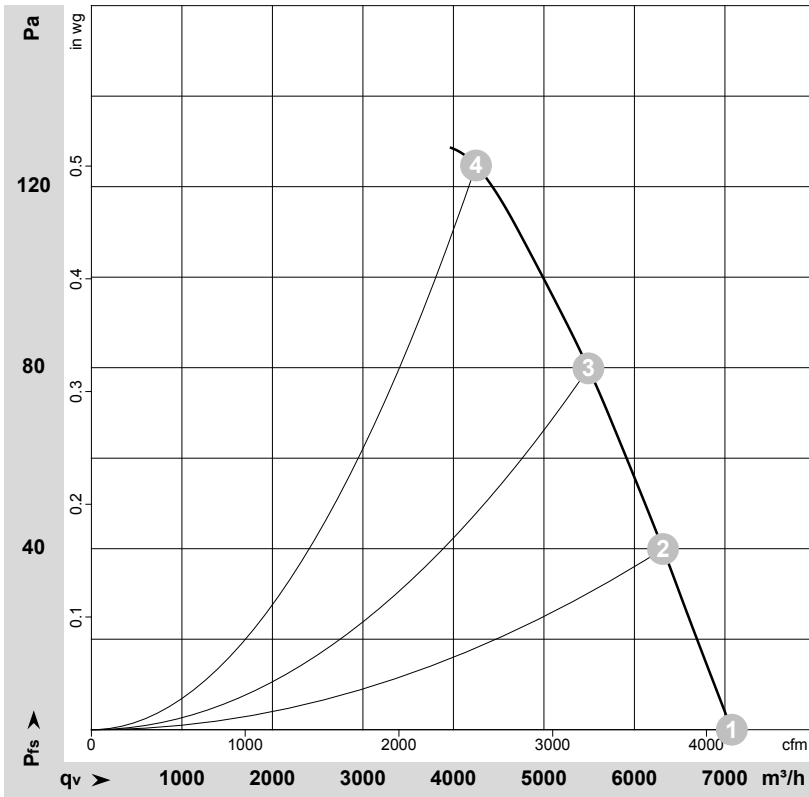

$\rho = 1.179 \text{ kg/m}^3 \pm 2 \%$

Measurement: LU-106846-1

Air performance measured according to ISO 5801 installation category A. For detailed information on the measurement setup, contact ebmpapst. Intake sound level: Sound power level according to ISO 13347 / sound pressure level measured at 1 m distance from fan axis. The values given are valid under the specified measuring conditions and may vary due to conditions of installation. For deviations from the standard configuration, the parameters have to be checked on the installed unit.

## Measured values

	U	f	n	P <sub>e</sub>	I	LpA <sub>in</sub>	LwA <sub>in</sub>	LwA <sub>out</sub>	qv	P <sub>fs</sub>	qv	P <sub>fs</sub>
	V	Hz	min <sup>-1</sup>	W	A	dB(A)	dB(A)	dB(A)	m <sup>3</sup> /h	Pa	CFM	inH <sub>2</sub> O
1	230	50	1350	423	2.05	63	69	70	7075	0	4165	0.00
2	230	50	1340	447	2.16	62	68	69	6315	40	3715	0.16
3	230	50	1325	470	2.26	62	68	69	5490	80	3230	0.32
4	230	50	1310	490	2.36	62	69	69	4250	125	2500	0.50

U = Power supply · f = Frequency · n = Speed (rpm) · P<sub>e</sub> = Power consumption · I = Current draw · LpA<sub>in</sub> = Sound pressure level intake side · LwA<sub>in</sub> = Sound power level intake side  
 LwA<sub>out</sub> = Sound power level outlet side · qv = Air flow · P<sub>fs</sub> = Pressure increase



## Curves: Air performance 60 Hz

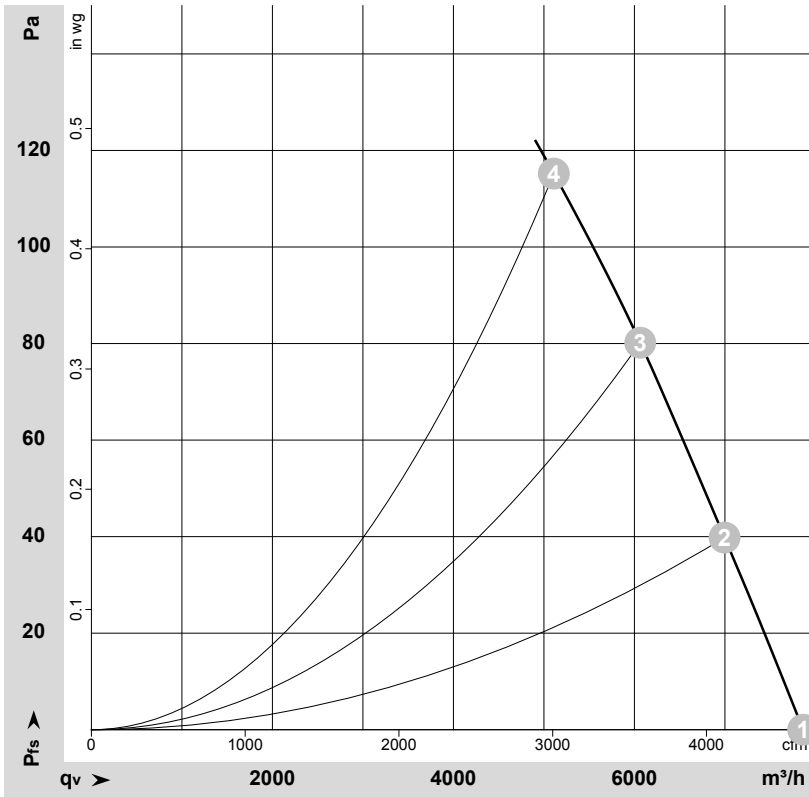

$\rho = 1.178 \text{ kg/m}^3 \pm 2 \%$

Measurement: LU-106848-1

Air performance measured according to ISO 5801 installation category A. For detailed information on the measurement setup, contact ebmpapst. Intake sound level: Sound power level according to ISO 13347 / sound pressure level measured at 1 m distance from fan axis. The values given are valid under the specified measuring conditions and may vary due to conditions of installation. For deviations from the standard configuration, the parameters have to be checked on the installed unit.

## Measured values

	U	f	n	P <sub>e</sub>	I	LpA <sub>in</sub>	LwA <sub>in</sub>	LwA <sub>out</sub>	qv	P <sub>fs</sub>	qv	P <sub>fs</sub>
	V	Hz	min <sup>-1</sup>	W	A	dB(A)	dB(A)	dB(A)	m <sup>3</sup> /h	Pa	CFM	inH <sub>2</sub> O
1	230	60	1500	593	2.64	65	72	73	7865	0	4630	0.00
2	230	60	1455	616	2.76	64	70	71	6995	40	4120	0.16
3	230	60	1415	638	2.88	63	70	71	6065	80	3570	0.32
4	230	60	1390	650	2.96	62	69	70	5110	115	3010	0.46

U = Power supply · f = Frequency · n = Speed (rpm) · P<sub>e</sub> = Power consumption · I = Current draw · LpA<sub>in</sub> = Sound pressure level intake side · LwA<sub>in</sub> = Sound power level intake side  
LwA<sub>out</sub> = Sound power level outlet side · qv = Air flow · P<sub>fs</sub> = Pressure increase

