

A4E450-AN05-01 ebmpapst Datasheet

sales@fansco.com

www.fansco.com

Nominal data

Type	A4E450-AN05-01	
Motor	M4E094-FA	
Phase		1~
Nominal voltage	VAC	230
Frequency	Hz	50
Method of obtaining data		ml
Valid for approval/standard		CE
Speed (rpm)	min ⁻¹	1300
Power consumption	W	450
Current draw	A	2.1
Capacitor	µF	8
Capacitor voltage	VDB	400
Max. back pressure	Pa	120
Max. back pressure	in. wg	0.48
Min. ambient temperature	°C	-40
Max. ambient temperature	°C	60

ml = Max. load · me = Max. efficiency · fa = Free air · cs = Customer specification · ce = Customer equipment
Subject to change

Data according to Commission Regulation (EU) 327/2011 (prEN 17166)

		Actual	Req. 2015			
01 Overall efficiency η_{es}	%	31.5	31.4	09 Power consumption P_e	kW	0.43
02 Measurement category		A		09 Air flow q_v	m ³ /h	4520
03 Efficiency category		Static		09 Pressure increase p_{fs}	Pa	111
04 Efficiency grade N		40.1	40	10 Speed (rpm) n	min ⁻¹	1315
05 Variable speed drive		No		11 Specific ratio*		1.00

Data obtained at optimum efficiency level.

The efficiency values displayed for achieving conformity with the Ecodesign Regulation EU 327/2011 has been reached with defined air duct components (e.g. inlet rings).

The dimensions must be requested from ebm-papst. If other air conduction geometries are used on the installation side, the ebm-papst evaluation loses its validity/the conformity must be confirmed again.

The product does not fall within the scope of Regulation (EU) 2019/1781 due to the exception specified in Article 2 (2a) (motors completely integrated into a product).

* Specific ratio = $1 + p_{fs} / 100\,000\text{ Pa}$

LU-201651



Technical description

Weight	6 kg
Size	450 mm
Motor size	94
Rotor surface	Painted black
Terminal box material	PP plastic
Blade material	Press-fitted sheet steel blank, sprayed with PP plastic
Number of blades	5
Airflow direction	V
Direction of rotation	Counterclockwise, viewed toward rotor
Degree of protection	IP54
Insulation class	"F"
Moisture (F) / Environmental (H) protection class	H2
Ambient temperature note	Occasional start-up at temperatures between -40°C and -25°C is permitted. For continuous operation at ambient temperatures below -25°C (such as refrigeration applications), use must be made of a fan design with special low-temperature bearings.
Max. permitted ambient temp. for motor (transport/storage)	+80 °C
Min. permitted ambient temp. for motor (transport/storage)	-40 °C
Installation position	Shaft horizontal or rotor on bottom; rotor on top on request
Condensation drainage holes	On rotor side
Mode	S1
Motor bearing	Ball bearing
Touch current according to IEC 60990 (measuring circuit Fig. 4, TN system)	<= 3.5 mA
Electrical hookup	Terminal box
Motor protection	Thermal overload protector (TOP) with basic insulation
Protection class	I (with customer connection of protective earth)
Motor capacitor according to EN 60252-1 in safety protection class	S0
Conformity with standards	EN 60034-1 (2010); CE; UKCA
Approval	EAC

AC axial fan

sickle-shaped blades (S series)

Product drawing

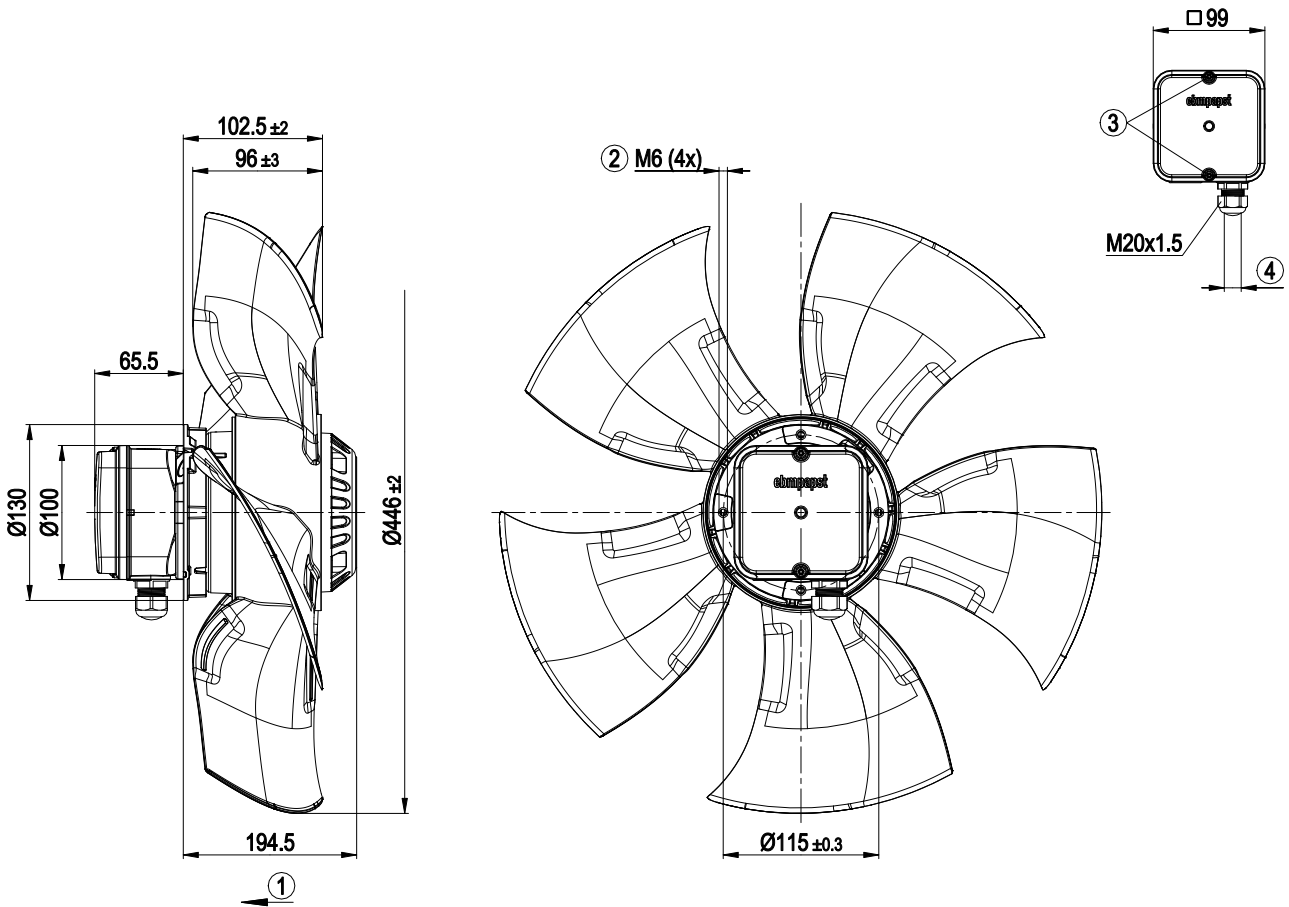

1	Direction of air flow "V"
2	Max. clearance for screw 12 mm
3	Tightening torque 1.5 ± 0.2 Nm
4	Cable diameter min. 6 mm, max. 12 mm, tightening torque 2 ± 0.3 Nm



Connection diagram

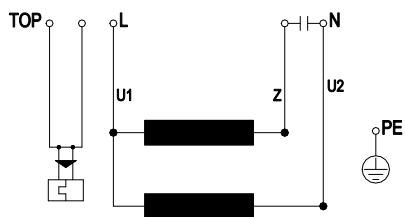

TOP	2x gray	U1	blue	Z	brown
U2	black	PE	green/yellow		

Curves: Air performance 50 Hz

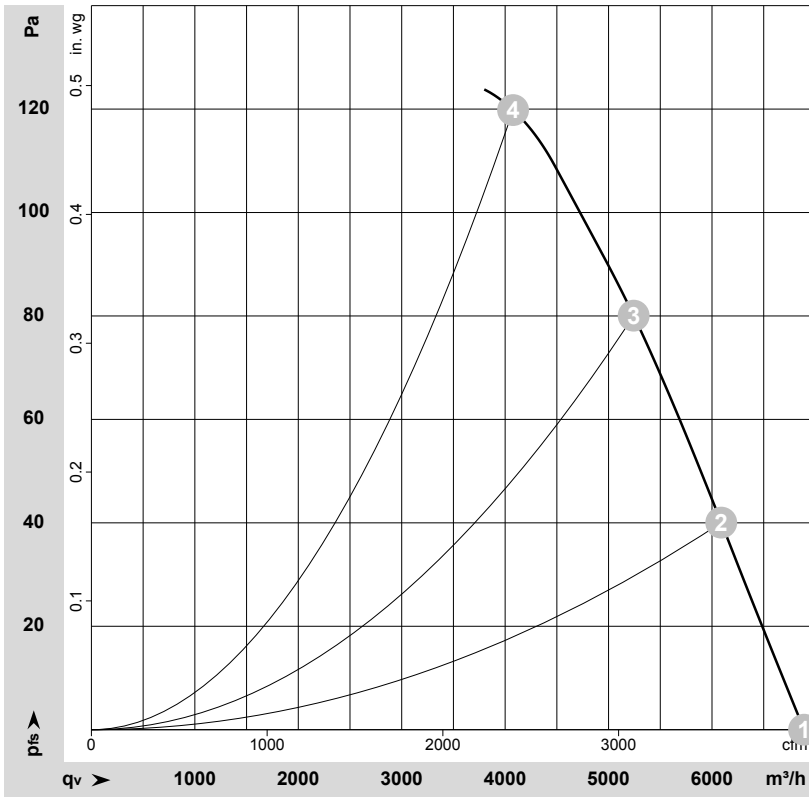

$\rho = 1.15 \text{ kg/m}^3 \pm 2 \%$

Measurement: LU-108810-1

Air performance measured according to ISO 5801 installation category A. For detailed information on the measurement setup, contact ebmpapst. Intake sound level: Sound power level according to ISO 13347 / sound pressure level measured at 1 m distance from fan axis. The values given are valid under the specified measuring conditions and may vary due to conditions of installation. For deviations from the standard configuration, the parameters have to be checked on the installed unit.

Measured values

	Wired	U	f	n	P _e	I	LpA _{in}	LwA _{in}	LwA _{out}	q _v	p _{fs}	q _v	p _{fs}
		V	Hz	min ⁻¹	W	A	dB(A)	dB(A)	dB(A)	m ³ /h	Pa	cfm	in. wg
1	1~	230	50	1360	377	1.78	64	69	70	6890	0	4055	0.00
2	1~	230	50	1335	403	1.89	61	67	68	6090	40	3585	0.16
3	1~	230	50	1315	428	1.98	61	67	67	5245	80	3085	0.32
4	1~	230	50	1300	450	2.10	62	68	68	4075	120	2400	0.48

Wired = Wiring · U = Voltage · f = Frequency · n = Speed (rpm) · P_e = Power consumption · I = Current draw · LpA_{in} = Sound pressure level intake side · LwA_{in} = Sound power level intake side
 LwA_{out} = Sound power level outlet side · q_v = Air flow · p_{fs} = Pressure increase

