

# AC axial fan

sickled blades (S series)

A4E400-AQ12-01 ebmpapst Datasheet  
 sales@fansco.com  
 www.fansco.com

Limited partnership · Headquarters Mulfingen  
 County court Stuttgart · HRA 590344

General partner Elektrobau Mulfingen GmbH · Headquarters Mulfingen  
 County court Stuttgart · HRB 590142

## Nominal data

Type	A4E400-AQ12-01	
Motor	M4E074-DF	
Phase		1~
Nominal voltage	VAC	230
Frequency	Hz	50
Type of data definition		fa
Valid for approval / standard		CE
Speed (rpm)	min <sup>-1</sup>	1400
Power input	W	150
Current draw	A	0.66
Motor capacitor	µF	5
Capacitor voltage	VDB	400
Max. back pressure	Pa	70
Min. ambient temperature	°C	-25
Max. ambient temperature	°C	60

ml = Max. load · me = Max. efficiency · fa = Running at free air · cs = Customer specs · cu = Customer unit  
 Subject to alterations

## Data according to ErP directive

		Actual	Request 2015		
01 Overall efficiency $\eta_{es}$	%	29	29	09 Power input $P_e$	kW 0.18
02 Measurement category		A		09 Air flow $q_v$	m <sup>3</sup> /h 2790
03 Efficiency category		Static		09 Pressure increase $p_{fs}$	Pa 70
04 Efficiency grade N		40	40	10 Speed (rpm) n	min <sup>-1</sup> 1335
05 Variable speed drive		No		11 Specific ratio*	1.00

Data definition with optimum efficiency.  
 The ErP data is determined using a motor-impeller combination in a standardised measurement configuration.

\* Specific ratio =  $1 + p_g / 100\,000\text{ Pa}$

LU-33842



## Technical features

<b>Mass</b>	4.7 kg
<b>Size</b>	400 mm
<b>Surface of rotor</b>	Coated in black
<b>Material of blades</b>	Sheet steel, coated in black
<b>Number of blades</b>	5
<b>Direction of air flow</b>	"V"
<b>Direction of rotation</b>	Counter-clockwise, seen on rotor
<b>Type of protection</b>	IP 44; Depending on installation and position as per EN 60034-5 The IP protection is guaranteed only if the provided cable guard and terminal box are installed.
<b>Insulation class</b>	"F"
<b>Humidity (F)/environmental protection class (H)</b>	H0+
<b>Max. permissible ambient motor temp. (transp./ storage)</b>	+ 80 °C
<b>Min. permissible ambient motor temp. (transp./storage)</b>	- 40 °C
<b>Mounting position</b>	Shaft horizontal or rotor on bottom; rotor on top on request
<b>Condensate discharge holes</b>	Rotor-side
<b>Operation mode</b>	S1
<b>Motor bearing</b>	Ball bearing
<b>Touch current acc. IEC 60990 (measuring network Fig. 4, TN system)</b>	< 0.75 mA
<b>Motor protection</b>	Thermal overload protector (TOP) wired internally
<b>Cable exit</b>	Variable
<b>Protection class</b>	I (if protective earth is connected by customer)
<b>Product conforming to standard</b>	EN 60335-1; CE



Product drawing

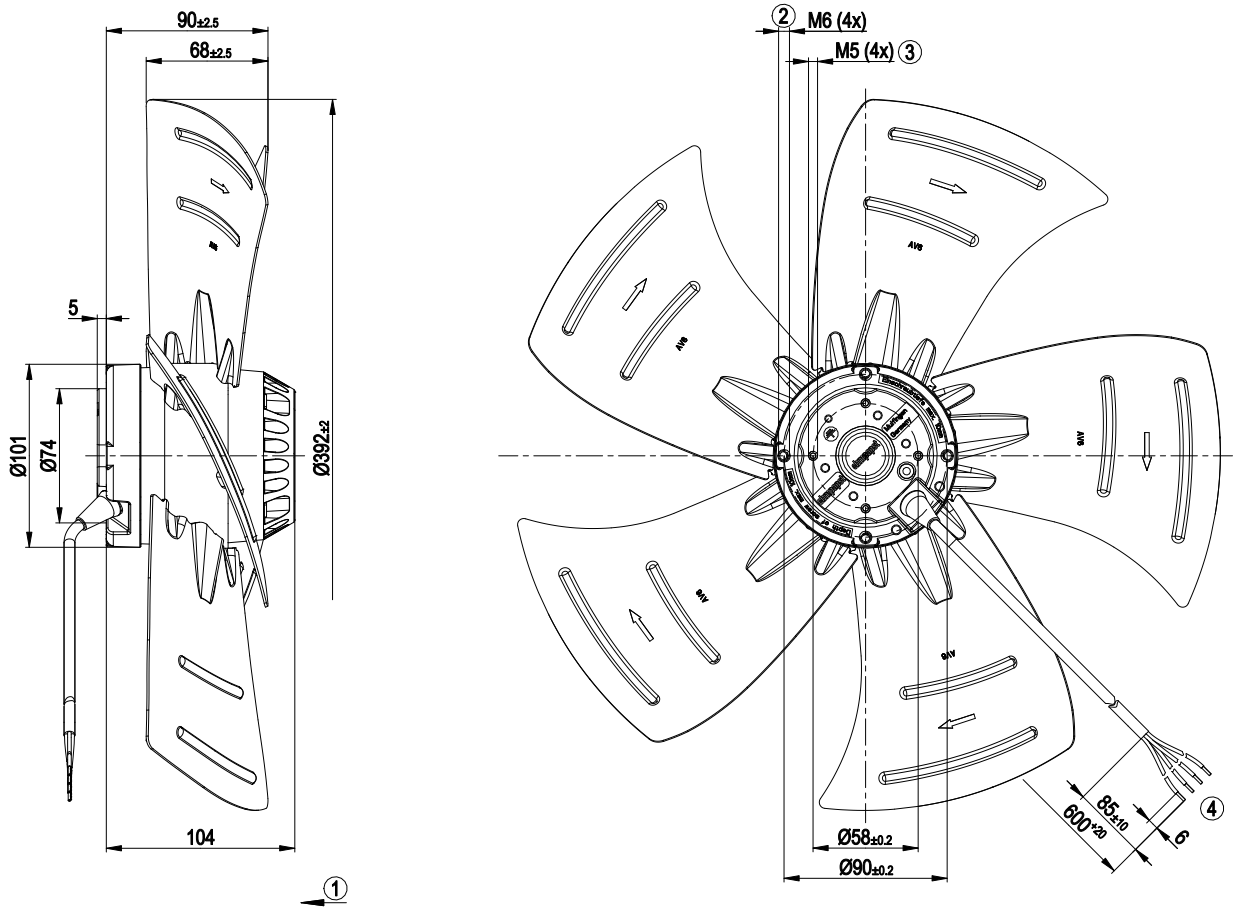

1	Direction of air flow "V"
2	Thread reach max. 10 mm
3	Thread reach max. 5 mm
4	Connection line silicone 4G 0.5 mm <sup>2</sup> , 4x crimped core-end sleeves



## Connection screen

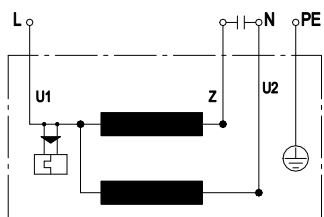

U1	blue	Z	brown	U2	black
PE	green/yellow				



## Charts: Air flow 50 Hz

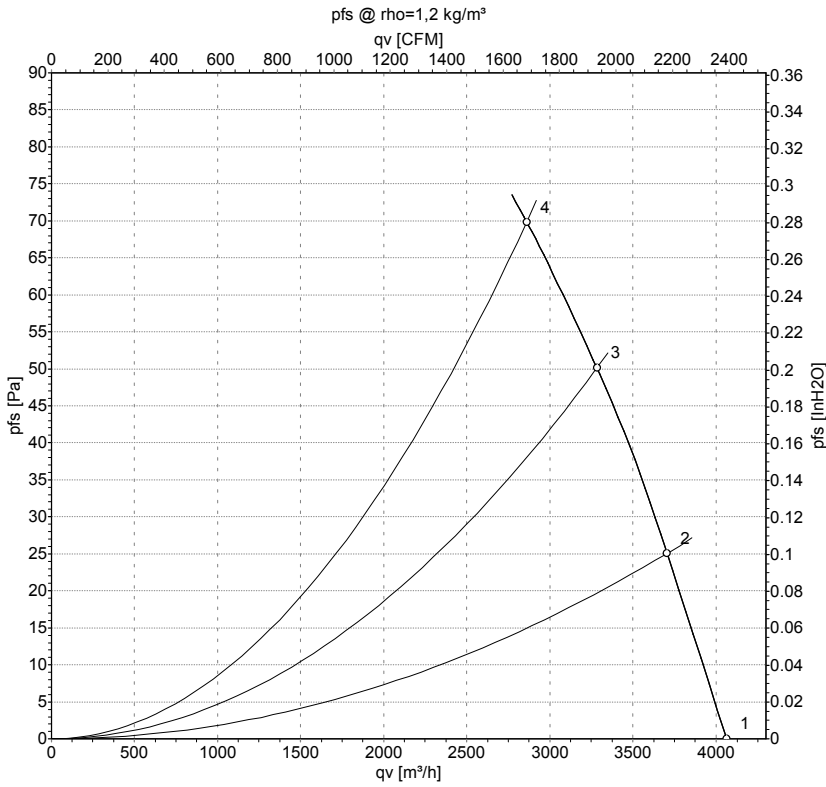

Measurement: LU-33842-1

Air performance measured as per ISO 5801 Installation category A. For detailed information on the measuring set-up, please contact ebmpapst. Suction-side noise levels: LwA measured as per ISO 13347 / LpA measured with 1m distance to fan axis. The values given are valid under the measuring conditions mentioned above and may vary according to the actual installation situation. With any deviation from the standard set-up, the specific values have to be checked and reviewed with the unit installed.

## Measured values

	U	f	n	P <sub>e</sub>	I	q <sub>v</sub>	p <sub>fs</sub>	q <sub>v</sub>	p <sub>fs</sub>
	V	Hz	min <sup>-1</sup>	W	A	m³/h	Pa	cfm	inH2O
1	230	50	1400	150	0.66	4065	0	2390	0.00
2	230	50	1385	158	0.69	3705	25	2180	0.10
3	230	50	1360	171	0.75	3285	50	1930	0.20
4	230	50	1340	184	0.80	2860	70	1685	0.28

U = Supply voltage · f = Frequency · n = Speed (rpm) · P<sub>e</sub> = Power input · I = Current draw · q<sub>v</sub> = Air flow · p<sub>fs</sub> = Pressure increase

