



A4E350-AR06-05 ebmpapst Datasheet

sales@fansco.com

www.fansco.com

Limited partnership · Headquarters Muldingen
County court Stuttgart · HRA 590344

General partner Elektrobau Muldingen GmbH · Headquarters Muldingen
County court Stuttgart · HRB 590142



Nominal data

Type	A4E350-AR06-05		
Motor	M4E068-EC		
Phase		1~	1~
Nominal voltage	VAC	230	230
Frequency	Hz	50	60
Type of data definition		fa	fa
Valid for approval / standard		CE	CE
Speed	min ⁻¹	1365	1530
Power input	W	132	180
Current draw	A	0.58	0.8
Motor capacitor	µF	5	5
Capacitor voltage	VDB	400	400
Capacitor standard		P0 (CE)	P0 (CE)
Max. back pressure	Pa	90	65
Min. ambient temperature	°C	-25	-25
Max. ambient temperature	°C	60	50
Starting current	A	1.4	1.3

ml = Max. load · me = Max. efficiency · fa = Running at free air · cs = Customer specs · cu = Customer unit
Subject to alterations

Data according to ErP directive

Installation category	A
Efficiency category	Static
Variable speed drive	No
Specific ratio*	1.00

* Specific ratio = $1 + p_b / 100\,000\text{ Pa}$

	Actual	Request 2013	Request 2015
Overall efficiency η_{es}	26.3	24.6	28.6
Efficiency grade N	37.7	36	40
Power input P_e	kW	0.16	
Air flow q_v	m ³ /h	2095	
Pressure increase p_{fs}	Pa	73	
Speed n	min ⁻¹	1285	

Data established at point of optimum efficiency



AC axial fan

sickled blades (S series), single inlet

Technical features

Mass	3.3 kg
Size	350 mm
Surface of rotor	Coated in black
Material of blades	Sheet steel, coated in black
Number of blades	5
Direction of air flow	"V"
Direction of rotation	Counter-clockwise, seen on rotor
Type of protection	IP 44; Depending on installation and position
Insulation class	"F"
Humidity class	F5
Max. permissible ambient motor temp. (transp./ storage)	+ 80 °C
Min. permissible ambient motor temp. (transp./storage)	- 40 °C
Mounting position	Shaft horizontal or rotor on bottom; rotor on top on request
Condensate discharge holes	Rotor-side
Operation mode	S1
Motor bearing	Ball bearing
Touch current acc. IEC 60990 (measuring network Fig. 4, TN system)	< 0.75 mA
Motor protection	Thermal overload protector (TOP) wired internally
Cable exit	Lateral
Protection class	I (if protective earth is connected by customer)
Product conforming to standard	CE



AC axial fan

sickled blades (S series), single inlet

Product drawing

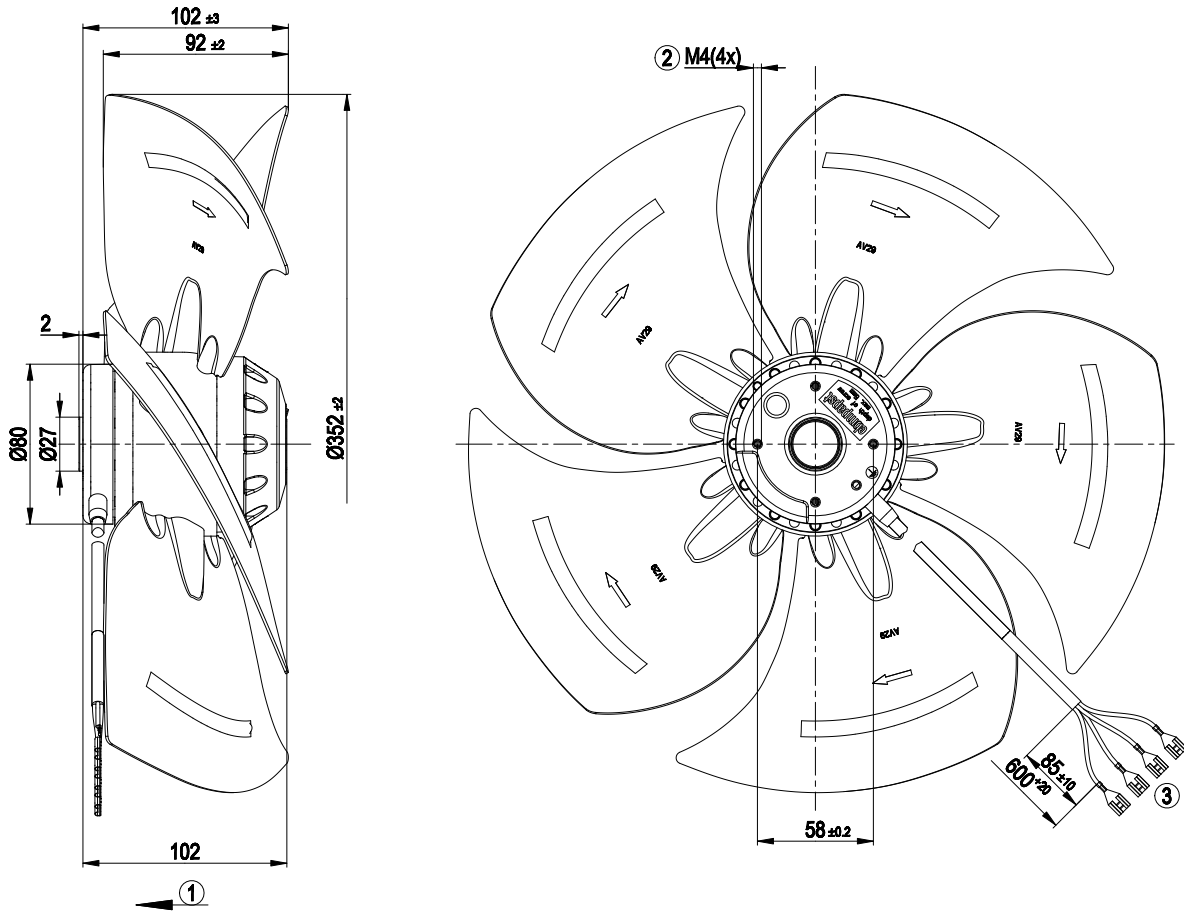

1	Direction of air flow "V"
2	Depth of screw max. 5 mm
3	Connection line silicone 4G 0.5mm ² , 4x receptacle for tabs 6.3 Stocko RSB 8178.108 crimped

Connection screen

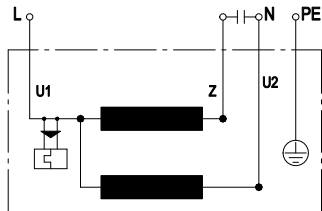

U1	blue	Z	brown	U2	black
PE	green/yellow				



Charts: Air flow 50 Hz

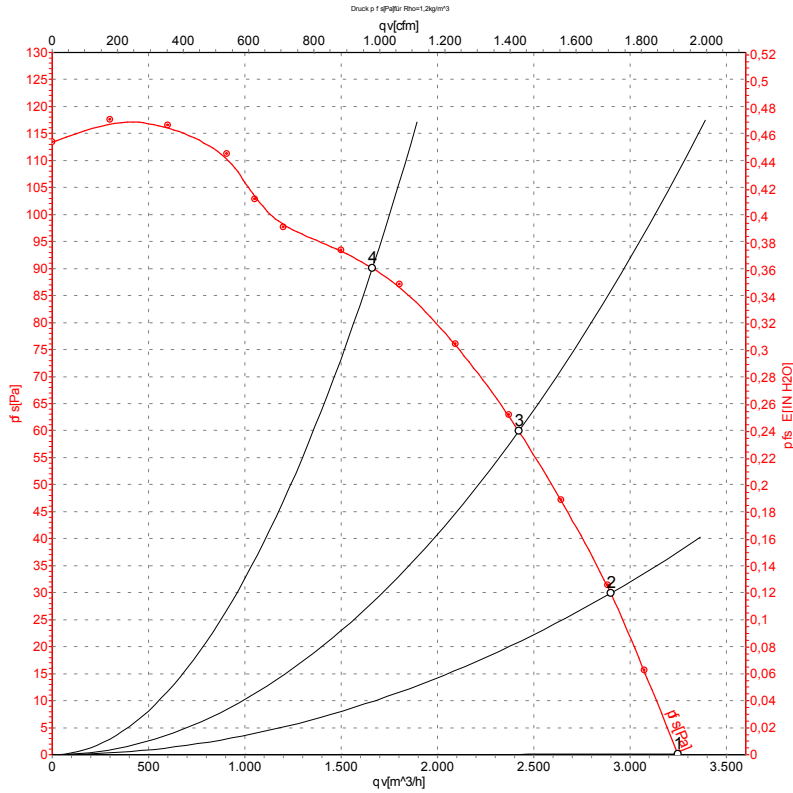

Measurement: LU-67365

Air performance measured as per ISO 5801 Installation category A. For detailed information on the measuring set-up, please contact ebm-papst. Suction-side noise levels: L_{wA} measured as per ISO 13347 / L_{pA} measured with 1m distance to fan axis. The values given are valid under the measuring conditions mentioned above and may vary according to the actual installation situation. With any deviation from the standard set-up, the specific values have to be checked and reviewed with the unit installed.

Measured values

	U	f	n	P _e	I	qv	P _{fs}
	V	Hz	min ⁻¹	W	A	m³/h	Pa
1	230	50	1365	132	0.58	3250	0
2	230	50	1340	142	0.62	2900	30
3	230	50	1305	154	0.68	2420	60
4	230	50	1220	178	0.79	1660	90

U = Supply voltage · f = Frequency · n = Speed · P_e = Power input · I = Current draw · qv = Air flow · P_{fs} = Pressure increase



Charts: Air flow 60 Hz

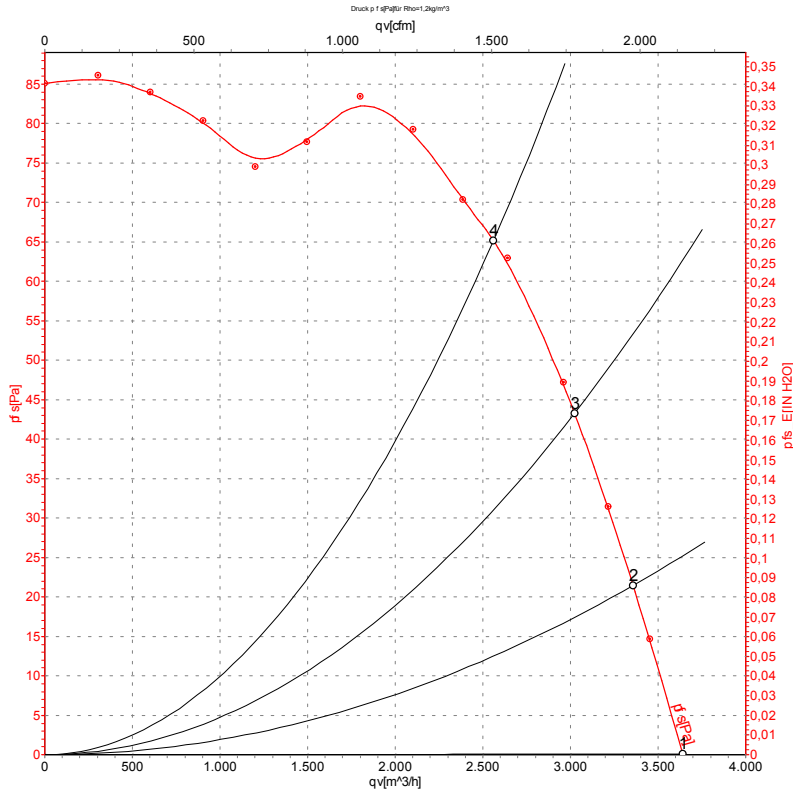

Measurement: LU-67366

Air performance measured as per ISO 5801 Installation category A. For detailed information on the measuring set-up, please contact ebm-papst. Suction-side noise levels: L_{wA} measured as per ISO 13347 / L_{pA} measured with 1m distance to fan axis. The values given are valid under the measuring conditions mentioned above and may vary according to the actual installation situation. With any deviation from the standard set-up, the specific values have to be checked and reviewed with the unit installed.

Measured values

	U	f	n	P _e	I	qv	p _{fs}
	V	Hz	min ⁻¹	W	A	m ³ /h	Pa
1	230	60	1530	180	0.80	3640	0
2	230	60	1490	187	0.82	3355	22
3	230	60	1440	196	0.85	3025	43
4	230	60	1360	206	0.89	2560	65

U = Supply voltage · f = Frequency · n = Speed · P_e = Power input · I = Current draw · qv = Air flow · p_{fs} = Pressure increase

