

A4E350-AQ02-09 ebmpapst Datasheet

sales@fansco.com

www.fansco.com

Limited partnership · Headquarters Muldingen

Amtsgericht (court of registration) Stuttgart · HRA 590344

General partner Elektrobau Muldingen GmbH · Headquarters Muldingen

Amtsgericht (court of registration) Stuttgart · HRB 590142



## Nominal data

|                             |                   |      |      |
|-----------------------------|-------------------|------|------|
| Type                        | A4E350-AQ02-09    |      |      |
| Motor                       | M4E074-EI         |      |      |
| Phase                       |                   | 1~   | 1~   |
| Nominal voltage             | VAC               | 230  | 230  |
| Frequency                   | Hz                | 50   | 60   |
| Method of obtaining data    |                   | ce   | ce   |
| Valid for approval/standard |                   | CE   | CE   |
| Speed (rpm)                 | min <sup>-1</sup> | 1420 | 1660 |
| Power consumption           | W                 | 180  | 275  |
| Current draw                | A                 | 0.8  | 1.2  |
| Capacitor                   | µF                | 6    | 6    |
| Capacitor voltage           | VDB               | 400  | 400  |
| Min. ambient temperature    | °C                | -40  | -40  |
| Max. ambient temperature    | °C                | 50   | 50   |
| Starting current            | A                 | 2.0  | 1.9  |

ml = Max. load · me = Max. efficiency · fa = Free air · cs = Customer specification · ce = Customer equipment

Subject to change

## Data according to ErP Directive

|                                   |   | Actual | Req. 2015 |                               |                   |      |
|-----------------------------------|---|--------|-----------|-------------------------------|-------------------|------|
| 01 Overall efficiency $\eta_{es}$ | % | 31.4   | 28.8      | 09 Power consumption $P_e$    | kW                | 0.17 |
| 02 Measurement category           |   | A      |           | 09 Air flow $q_v$             | m <sup>3</sup> /h | 2445 |
| 03 Efficiency category            |   | Static |           | 09 Pressure increase $p_{fs}$ | Pa                | 80   |
| 04 Efficiency grade N             |   | 42.6   | 40        | 10 Speed (rpm) n              | min <sup>-1</sup> | 1415 |
| 05 Variable speed drive           |   | No     |           | 11 Specific ratio*            |                   | 1.00 |

Data obtained at optimum efficiency level.

The ErP data is determined using a motor-impeller combination in a standardized measurement setup.

\* Specific ratio =  $1 + p_g / 100\,000\text{ Pa}$ 

LU-71990



### Technical description

|  |  |
|--|--|
| Weight   | 4.15 kg  |
| Fan size   | 350 mm   |
| Rotor surface  | Painted black  |
| Blade material   | Sheet steel  |
| Number of blades   | 5  |
| Airflow direction  | "V"  |
| Direction of rotation  | Counterclockwise, viewed toward rotor                        |
| Degree of protection   | IP44   |
| Insulation class   | "F"  |
| Moisture (F) / Environmental (H) protection class                          | F2-2   |
| Max. permitted ambient temp. for motor (transport/storage)                 | + 70 °C  |
| Min. permitted ambient temp. for motor (transport/storage)                 | - 40 °C  |
| Installation position  | Shaft horizontal or rotor on bottom; rotor on top on request |
| Condensation drainage holes  | On rotor side  |
| Mode   | S1   |
| Motor bearing  | Ball bearing with low-temperature lubricant                  |
| Touch current according to IEC 60990 (measuring circuit Fig. 4, TN system) | < 0.75 mA  |
| Motor protection   | Thermal overload protector (TOP) internally connected        |
| With cable   | Variable   |
| Protection class   | I (with customer connection of protective earth)             |
| Conformity with standards  | EN 60335-1; CE   |

## Product drawing

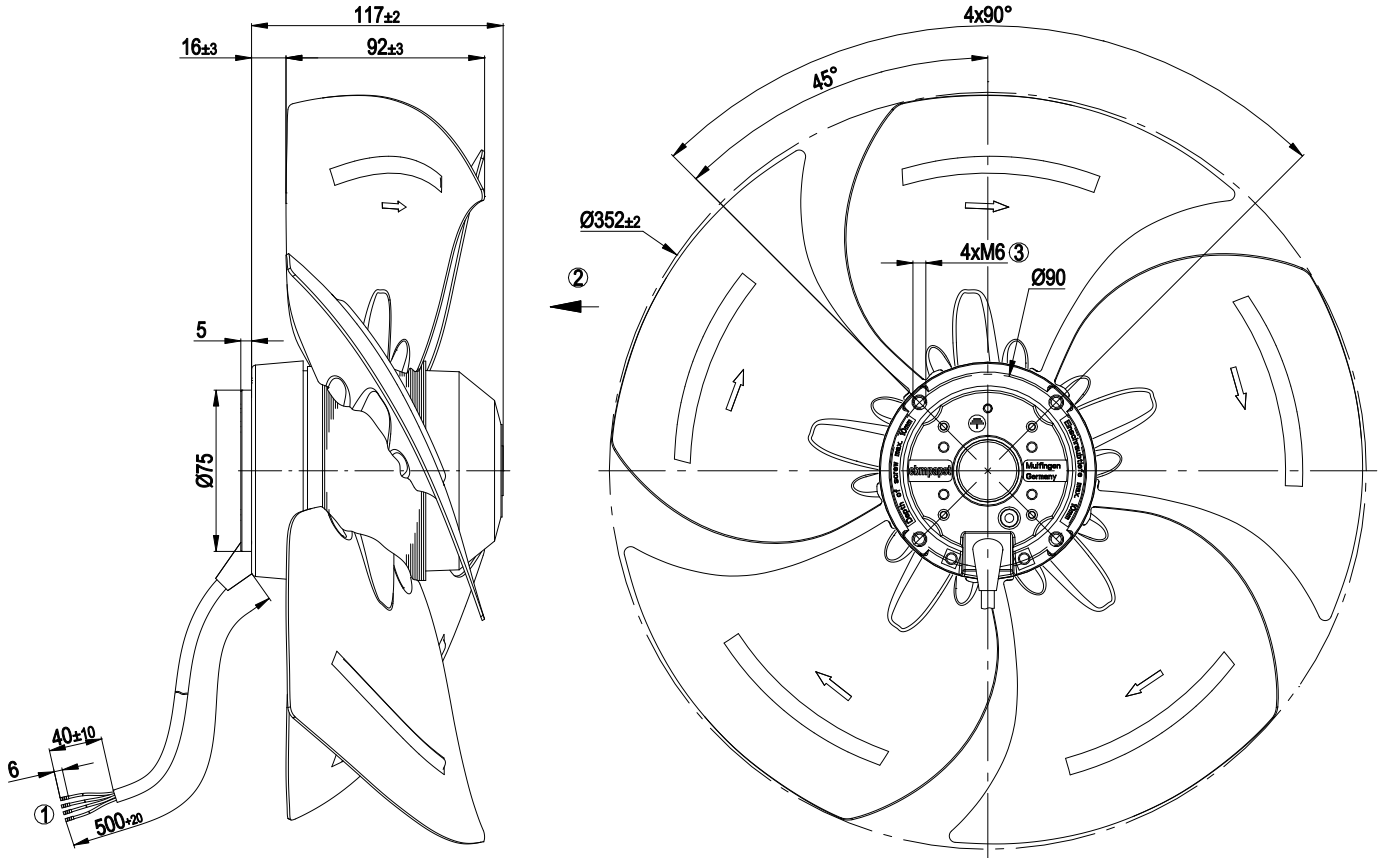

|   |                                    |
|---|------------------------------------|
| 1 | Cable silicone, 4x crimped splices |
| 2 | Direction of air flow "V"          |
| 3 | Max. clearance for screw 10 mm     |

## Connection diagram

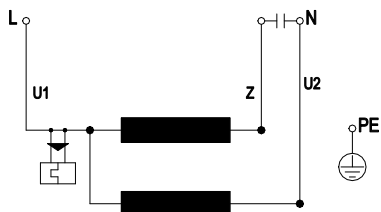

|    |              |   |       |    |       |
|----|--------------|---|-------|----|-------|
| U1 | blue         | Z | brown | U2 | black |
| PE | green/yellow |   |       |    |       |

## Curves: Air performance 50 Hz

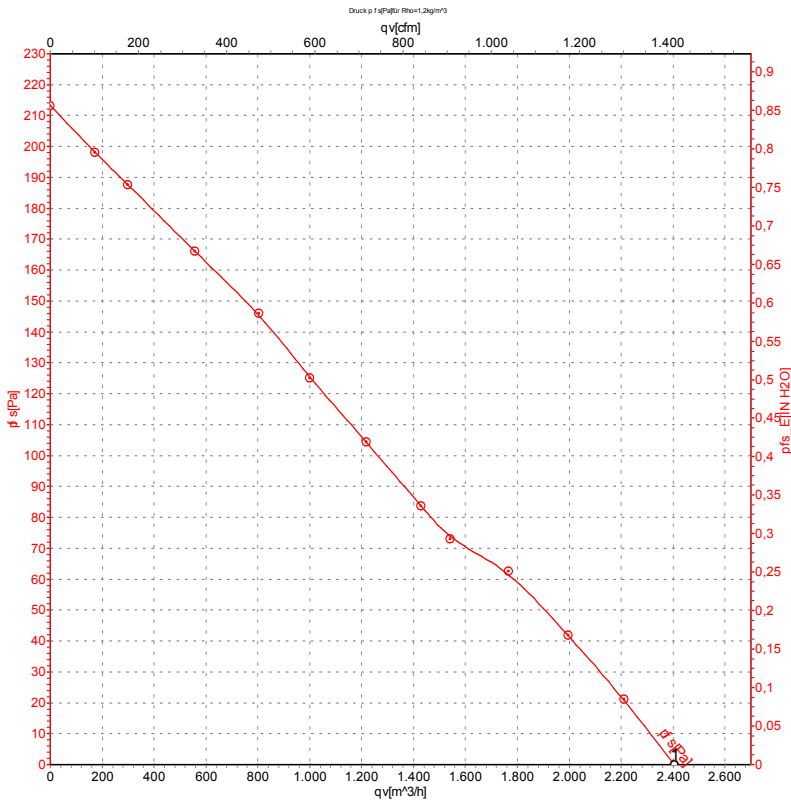

Measurement: LU-32761-1

Air performance measured according to ISO 5801 installation category A. For detailed information on the measurement setup, contact ebm-papst. Intake sound level: Sound power level according to ISO 13347 / sound pressure level measured at 1 m distance from fan axis. The values given are valid under the specified measuring conditions and may vary due to conditions of installation. For deviations from the standard configuration, the parameters have to be checked on the installed unit.

## Measured values

|   | U   | f  | n                 | P <sub>e</sub> | I    | qv                | qv   | p <sub>fs</sub>    |
|---|-----|----|-------------------|----------------|------|-------------------|------|--------------------|
|   | V   | Hz | min <sup>-1</sup> | W              | A    | m <sup>3</sup> /h | CFM  | inH <sub>2</sub> O |
| 1 | 230 | 50 | 1420              | 180            | 0.80 | 2405              | 1415 | 0.00               |

U = Power supply · f = Frequency · n = Speed (rpm) · P<sub>e</sub> = Power consumption · I = Current draw · qv = Air flow



## Curves: Air performance 60 Hz

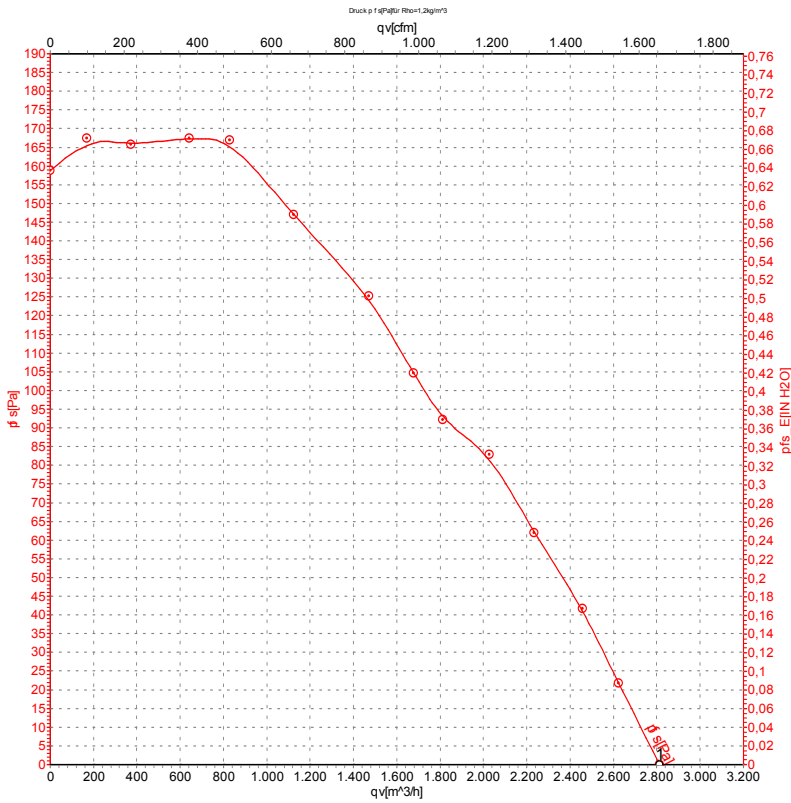

Measurement: LU-32762-1

Air performance measured according to ISO 5801 installation category A. For detailed information on the measurement setup, contact ebm-papst. Intake sound level: Sound power level according to ISO 13347 / sound pressure level measured at 1 m distance from fan axis. The values given are valid under the specified measuring conditions and may vary due to conditions of installation. For deviations from the standard configuration, the parameters have to be checked on the installed unit.

## Measured values

|   | U   | f  | n                 | P <sub>e</sub> | I    | qv                | qv   | p <sub>fs</sub>    |
|---|-----|----|-------------------|----------------|------|-------------------|------|--------------------|
|   | V   | Hz | min <sup>-1</sup> | W              | A    | m <sup>3</sup> /h | CFM  | inH <sub>2</sub> O |
| 1 | 230 | 60 | 1660              | 275            | 1.20 | 2815              | 1655 | 0.00               |

U = Power supply · f = Frequency · n = Speed (rpm) · P<sub>e</sub> = Power consumption · I = Current draw · qv = Air flow

