



A4E350-AP06-32 ebmpapst Datasheet

sales@fansco.com

www.fansco.com

## Nominal data

Type	A4E350-AP06-32		
Motor	M4E074-DF		
Phase		1~	1~
Nominal voltage	VAC	230	230
Frequency	Hz	50	60
Method of obtaining data		fa	fa
Valid for approval/standard		CE	CE
Speed (rpm)	min <sup>-1</sup>	1400	1590
Power consumption	W	130	190
Current draw	A	0.58	0.83
Capacitor	μF	4	4
Capacitor voltage	VDB	400	400
Max. back pressure	Pa	90	60
Max. back pressure	in. wg	0.36	0.24
Min. ambient temperature	°C	-40	-40
Max. ambient temperature	°C	55	55
Starting current	A	1.2	1.1

ml = Max. load · me = Max. efficiency · fa = Free air · cs = Customer specification · ce = Customer equipment  
Subject to change

## Data according to Commission Regulation (EU) 327/2011

		Actual	Req. 2015
01 Overall efficiency $\eta_{es}$	%	29	28.6
02 Measurement category		A	
03 Efficiency category		Static	
04 Efficiency grade N		40.4	40
05 Variable speed drive		No	

Data obtained at optimum efficiency level.

The ErP data is determined using a motor-impeller combination in a standardized measurement setup.

09 Power consumption $P_e$	kW	0.15
09 Air flow $q_v$	m <sup>3</sup> /h	2245
09 Pressure increase $p_{fs}$	Pa	74
10 Speed (rpm) n	min <sup>-1</sup>	1330
11 Specific ratio*		1.00

\* Specific ratio =  $1 + p_{fs} / 100\,000\text{ Pa}$ 

LU-199285



## Technical description

Weight	3.4 kg
Size	350 mm
Motor size	74
Rotor surface	Painted black
Blade material	Sheet steel, painted black
Number of blades	5
Airflow direction	V
Direction of rotation	Counterclockwise, viewed toward rotor
Degree of protection	IP44; installation- and position-dependent as per EN 60034-5. The degree of protection is only assured when the intended cable guard and terminal box are installed.
Insulation class	"F"
Moisture (F) / Environmental (H) protection class	H1+
Max. permitted ambient temp. for motor (transport/storage)	+ 70 °C
Min. permitted ambient temp. for motor (transport/storage)	- 40 °C
Installation position	Shaft horizontal or rotor on bottom; rotor on top on request
Condensation drainage holes	On rotor side
Mode	S1
Motor bearing	Ball bearing with low-temperature lubricant
Touch current according to IEC 60990 (measuring circuit Fig. 4, TN system)	< 0.75 mA
Electrical hookup	Prepared for terminal box installation
Motor protection	Thermal overload protector (TOP) internally connected
With cable	Variable
Protection class	I (with customer connection of protective earth)
Conformity with standards	EN 60335-1; CE
Approval	CCC

## Product drawing

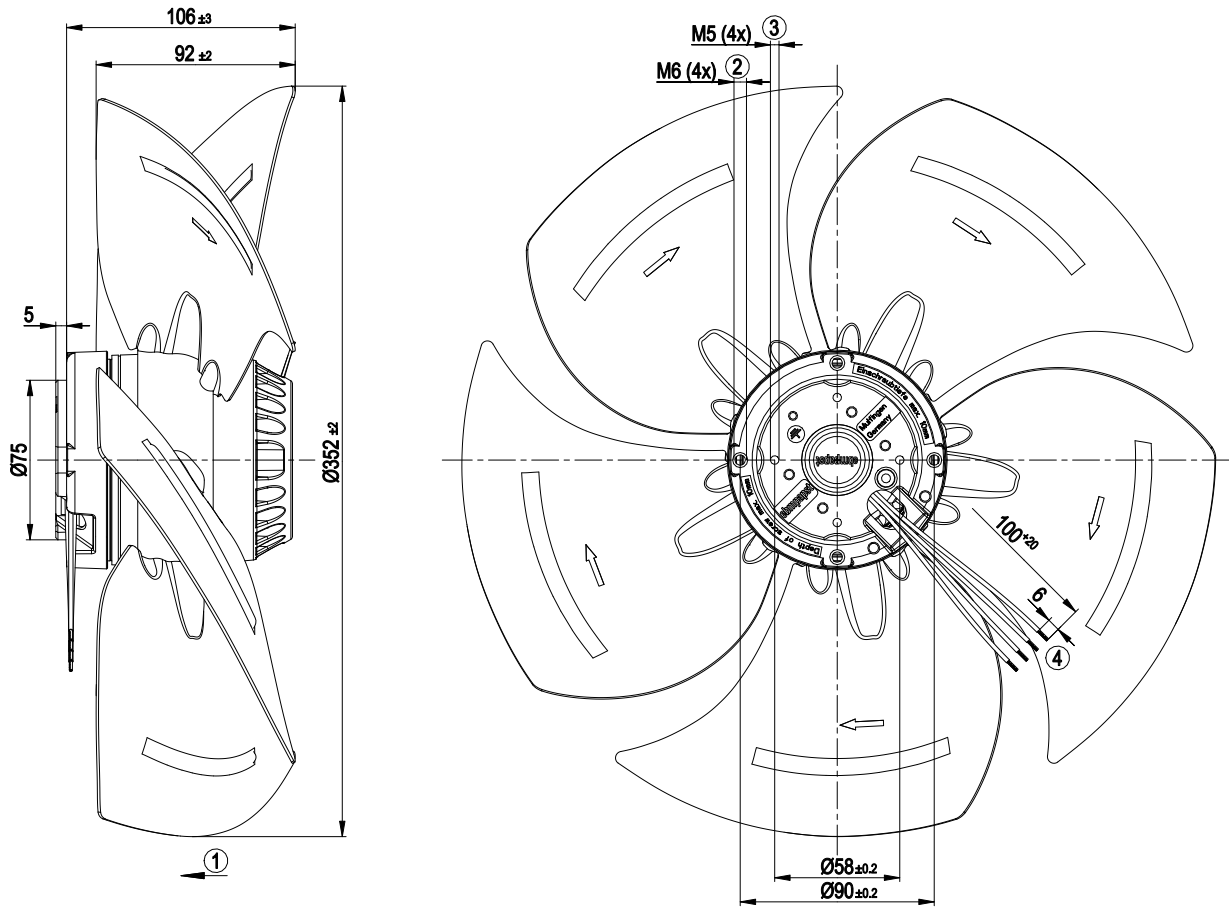

1	Direction of air flow "V"
2	Max. clearance for screw 10 mm
3	Max. clearance for screw 8 mm
4	Cable halogen-silicone-free 4G 0.5 mm <sup>2</sup> , 4x crimped splices

## Connection diagram

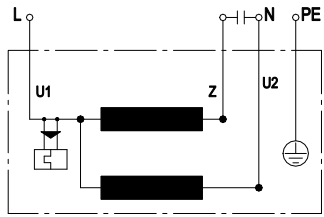

U1	blue	Z	brown	U2	black
PE	green/yellow				

## Curves: Air performance 50 Hz

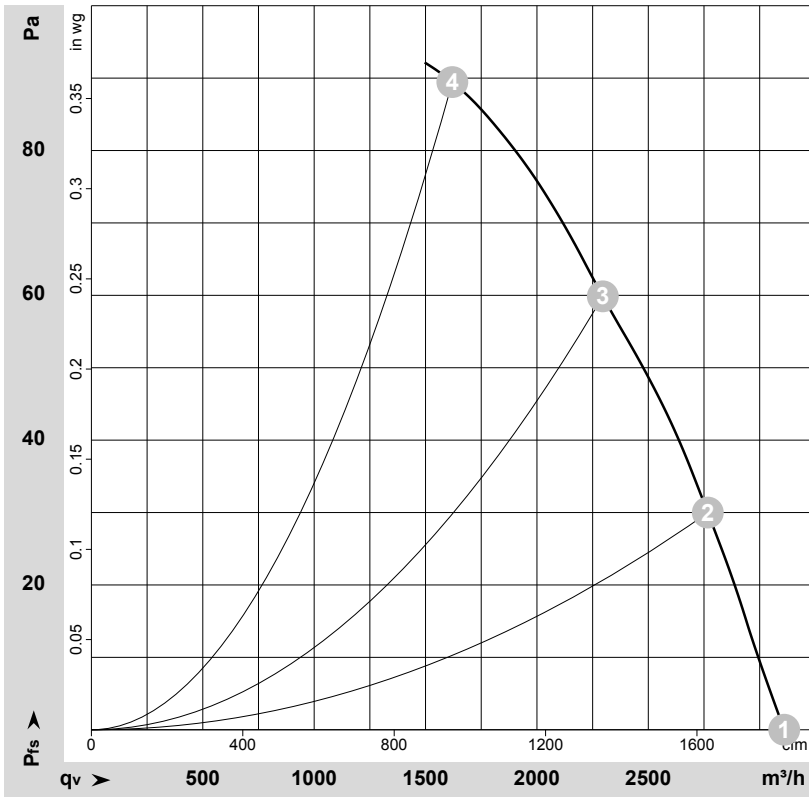

$\rho = 1.15 \text{ kg/m}^3 \pm 2 \%$

Measurement: LU-28525-1

Air performance measured according to ISO 5801 installation category A. For detailed information on the measurement setup, contact ebm-papst. Intake sound level: Sound power level according to ISO 13347 / sound pressure level measured at 1 m distance from fan axis. The values given are valid under the specified measuring conditions and may vary due to conditions of installation. For deviations from the standard configuration, the parameters have to be checked on the installed unit.

## Measured values

	U	f	n	P <sub>e</sub>	I	q <sub>v</sub>	P <sub>fs</sub>	q <sub>v</sub>	P <sub>fs</sub>
	V	Hz	min <sup>-1</sup>	W	A	m <sup>3</sup> /h	Pa	cfm	in. wg
1	230	50	1400	130	0.58	3110	0	1830	0.00
2	230	50	1380	140	0.62	2765	30	1630	0.12
3	230	50	1355	152	0.66	2295	60	1350	0.24
4	230	50	1275	179	0.78	1620	90	955	0.36

U = Voltage · f = Frequency · n = Speed (rpm) · P<sub>e</sub> = Power consumption · I = Current draw · q<sub>v</sub> = Air flow · p<sub>s</sub> = Pressure increase



## Curves: Air performance 60 Hz

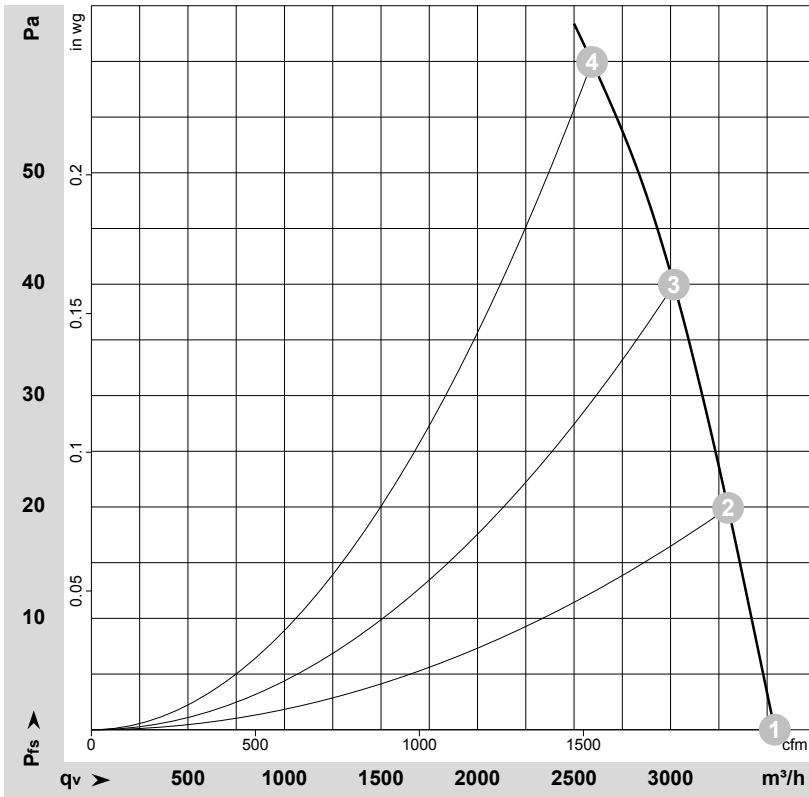

$\rho = 1.15 \text{ kg/m}^3 \pm 2 \%$

Measurement: LU-28527-1

Air performance measured according to ISO 5801 installation category A. For detailed information on the measurement setup, contact ebmpapst. Intake sound level: Sound power level according to ISO 13347 / sound pressure level measured at 1 m distance from fan axis. The values given are valid under the specified measuring conditions and may vary due to conditions of installation. For deviations from the standard configuration, the parameters have to be checked on the installed unit.

## Measured values

	U	f	n	P <sub>e</sub>	I	q <sub>v</sub>	p <sub>fs</sub>	q <sub>v</sub>	p <sub>fs</sub>
	V	Hz	min <sup>-1</sup>	W	A	m <sup>3</sup> /h	Pa	cfm	in. wg
1	230	60	1590	190	0.83	3540	0	2085	0.00
2	230	60	1565	197	0.85	3300	20	1940	0.08
3	230	60	1520	203	0.88	3015	40	1775	0.16
4	230	60	1445	209	0.91	2595	60	1525	0.24

U = Voltage · f = Frequency · n = Speed (rpm) · P<sub>e</sub> = Power consumption · I = Current draw · q<sub>v</sub> = Air flow · p<sub>fs</sub> = Pressure increase

