

A4E350-AO02-16 ebmpapst Datasheet
 sales@fansco.com
 www.fansco.com

Limited partnership · Headquarters Mulfingen
 County court Stuttgart · HRA 590344

General partner Elektrobau Mulfingen GmbH · Headquarters Mulfingen
 County court Stuttgart · HRB 590142

Nominal data

Type	A4E350-AO02-16		
Motor	M4E074-EI		
Phase		1~	1~
Nominal voltage	VAC	230	230
Frequency	Hz	50	60
Type of data definition		ml	ml
Valid for approval / standard		CE	CE
Speed (rpm)	min ⁻¹	1400	1600
Power input	W	180	250
Current draw	A	0.81	1.1
Motor capacitor	µF	5	5
Capacitor voltage	VDB	400	400
Capacitor standard		S0 (CE)	S0 (CE)
Max. back pressure	Pa	100	100
Min. ambient temperature	°C	-25	-25
Max. ambient temperature	°C	75	50
Starting current	A	2.2	1.92

ml = Max. load · me = Max. efficiency · fa = Running at free air · cs = Customer specs · cu = Customer unit
 Subject to alterations

Data according to ErP directive

	Actual	Request 2015	
01 Overall efficiency η_{es}	%	29.3	28.6
02 Measurement category	A		
03 Efficiency category	Static		
04 Efficiency grade N	40.7	40	
05 Variable speed drive	No		

Data definition with optimum efficiency.
 The ErP data is determined using a motor-impeller combination in a standardised measurement configuration.

09 Power input P_e	kW	0.16
09 Air flow q_v	m ³ /h	2260
09 Pressure increase p_{fs}	Pa	80
10 Speed (rpm) n	min ⁻¹	1410
11 Specific ratio*		1.00

* Specific ratio = $1 + p_{fs} / 100\,000\text{ Pa}$

LU-130206



Technical features

Mass	3.7 kg
Size	350 mm
Surface of rotor	Coated in black
Material of blades	PP plastic
Number of blades	5
Direction of air flow	"A"
Direction of rotation	Clockwise, seen on rotor
Type of protection	IP 44; Depending on installation and position as per EN 60034-5
Insulation class	"F"
Humidity (F)/environmental protection class (H)	F2-2
Max. permissible ambient motor temp. (transp./ storage)	+ 80 °C
Min. permissible ambient motor temp. (transp./storage)	- 40 °C
Mounting position	Shaft horizontal or rotor on bottom; rotor on top on request
Condensate discharge holes	None
Operation mode	S1
Motor bearing	Ball bearing
Touch current acc. IEC 60990 (measuring network Fig. 4, TN system)	< 0.75 mA
Electrical leads	Prepared for terminal box installation/assembly
Motor protection	Thermal overload protector (TOP) wired internally
Cable exit	Variable
Protection class	I (if protective earth is connected by customer)
Product conforming to standard	EN 60335-1; CE



Product drawing

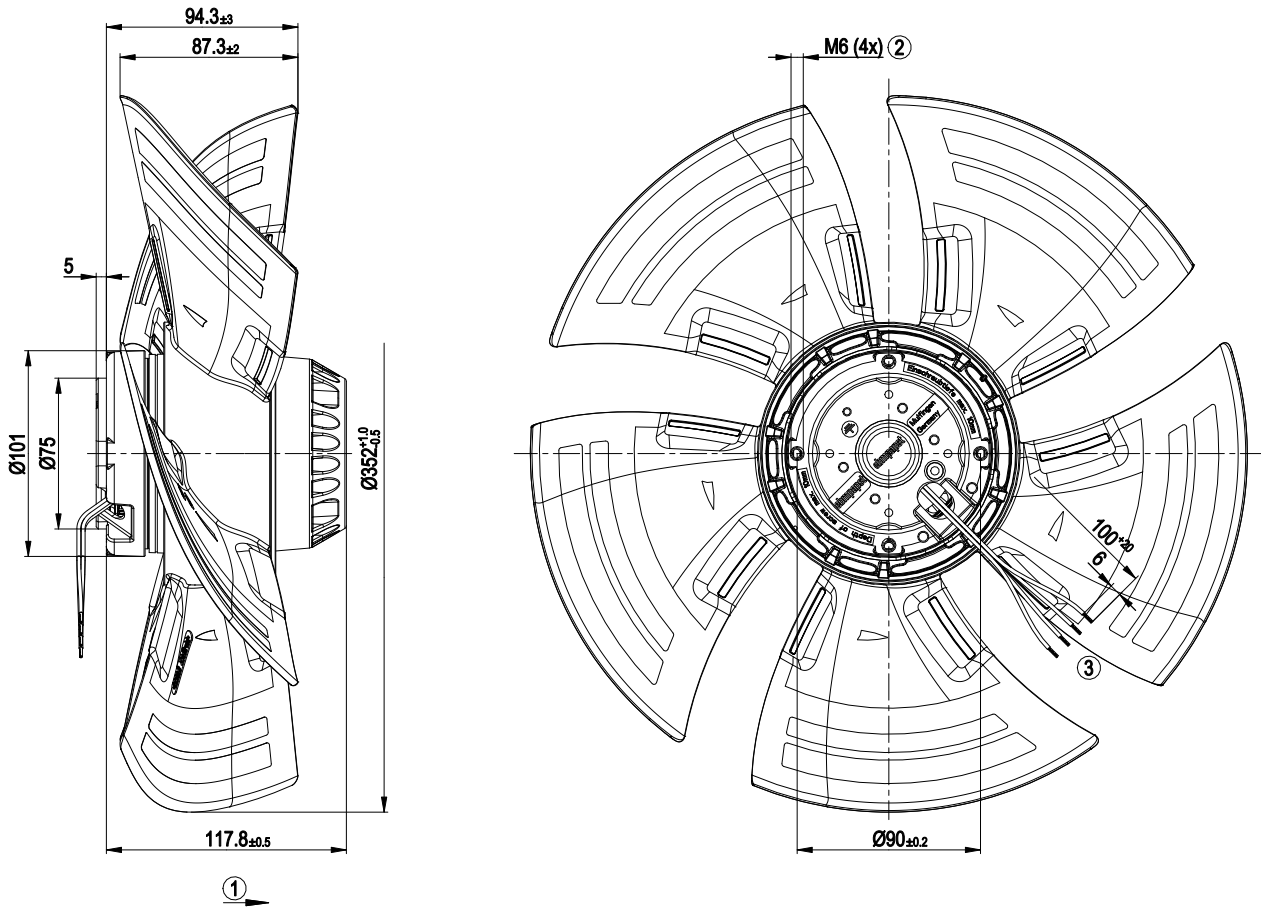

1	Direction of air flow "A"
2	Thread reach max. 10 mm
3	Connection line halogen-silicone-free 4x 0.5 mm ² , 4x lead tips crimped

Connection screen

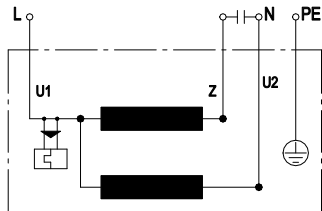

U1	blue	Z	brown	U2	black
PE	green/yellow				



Charts: Air flow 50 Hz

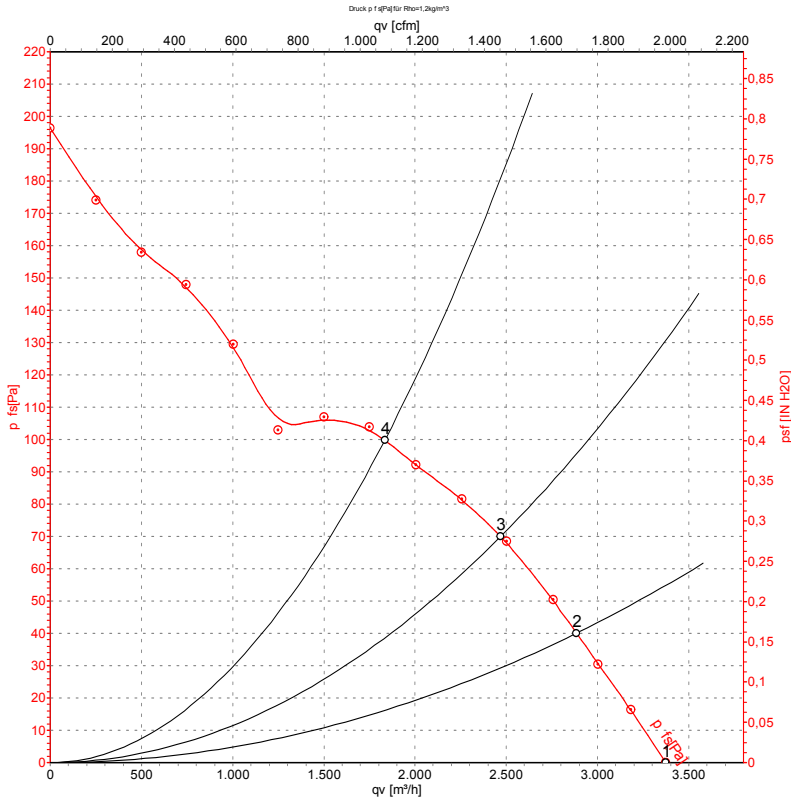

Measurement: LU-130206-1

Air performance measured as per ISO 5801 Installation category A. For detailed information on the measuring set-up, please contact ebm-papst. Suction-side noise levels: LwA measured as per ISO 13347 / LpA measured with 1m distance to fan axis. The values given are valid under the measuring conditions mentioned above and may vary according to the actual installation situation. With any deviation from the standard set-up, the specific values have to be checked and reviewed with the unit installed.

Measured values

	U	f	n	P _e	I	LpA _{in}	LwA _{in}	q _v	P _{fs}	q _v	P _{fs}
	V	Hz	min ⁻¹	W	A	dB(A)	dB(A)	m ³ /h	Pa	cfm	inH ₂ O
1	230	50	1435	143	0.68	62	70	3375	0	1985	0.00
2	230	50	1425	156	0.73	59	67	2885	40	1695	0.16
3	230	50	1415	166	0.76	56	64	2470	70	1455	0.28
4	230	50	1400	180	0.81	62	70	1835	100	1080	0.40

U = Supply voltage · f = Frequency · n = Speed (rpm) · P_e = Power input · I = Current draw · LpA_{in} = Sound pressure level inlet side · LwA_{in} = Sound power level inlet side · q_v = Air flow
 P_{fs} = Pressure increase



Charts: Air flow 60 Hz

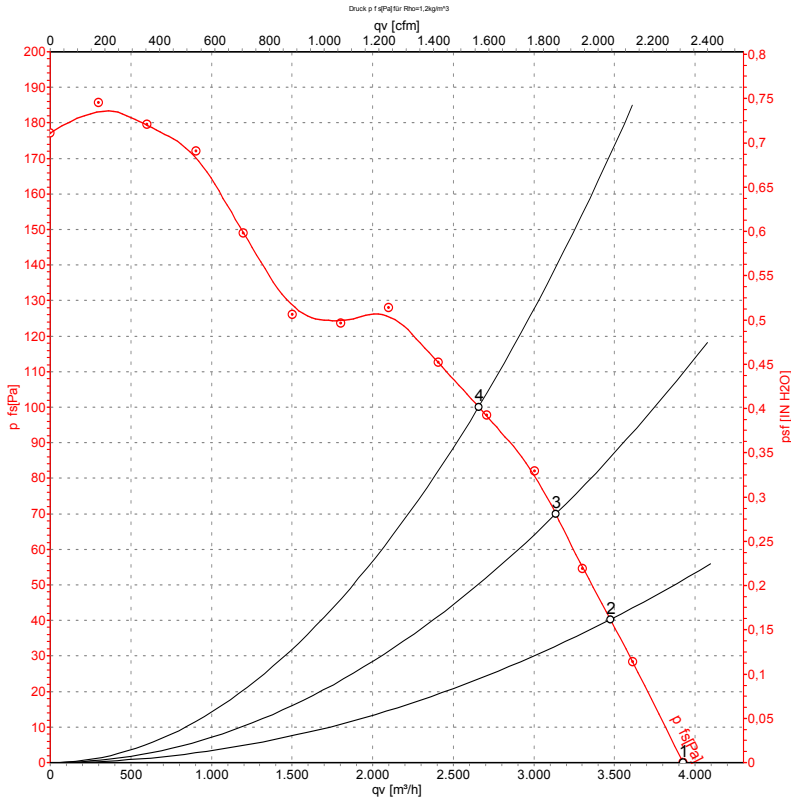

Measurement: LU-130207-1

Air performance measured as per ISO 5801 Installation category A. For detailed information on the measuring set-up, please contact ebmpapst. Suction-side noise levels: LwA measured as per ISO 13347 / LpA measured with 1m distance to fan axis. The values given are valid under the measuring conditions mentioned above and may vary according to the actual installation situation. With any deviation from the standard set-up, the specific values have to be checked and reviewed with the unit installed.

Measured values

	U	f	n	P _e	I	LpA _{in}	LwA _{in}	q _v	P _{fs}	q _v	P _{fs}
	V	Hz	min ⁻¹	W	A	dB(A)	dB(A)	m³/h	Pa	cfm	inH2O
1	230	60	1675	204	0.89	66	74	3925	0	2310	0.00
2	230	60	1650	224	0.98	63	71	3475	40	2045	0.16
3	230	60	1635	234	1.02	61	69	3135	70	1845	0.28
4	230	60	1600	250	1.10	59	67	2655	100	1565	0.40

U = Supply voltage · f = Frequency · n = Speed (rpm) · P_e = Power input · I = Current draw · LpA_{in} = Sound pressure level inlet side · LwA_{in} = Sound power level inlet side · q_v = Air flow
 P_{fs} = Pressure increase

