

A4E350-AO02-10 ebmpapst Datasheet

sales@fansco.com

www.fansco.com

Nominal data

Type	A4E350-AO02-10		
Motor	M4E074-EI		
Phase		1~	1~
Nominal voltage	VAC	230	230
Frequency	Hz	50	60
Method of obtaining data		ml	ml
Valid for approval/standard		CE	CE
Speed (rpm)	min ⁻¹	1400	1600
Power consumption	W	180	250
Current draw	A	0.81	1.1
Capacitor	μF	5	5
Capacitor voltage	VDB	400	400
Capacitor standard		S0 (CE)	S0 (CE)
Max. back pressure	Pa	100	100
Max. back pressure	in. wg	0.4	0.4
Min. ambient temperature	°C	-25	-25
Max. ambient temperature	°C	75	50
Starting current	A	2.2	1.92

ml = Max. load · me = Max. efficiency · fa = Free air · cs = Customer specification · ce = Customer equipment
Subject to change

Data according to Commission Regulation (EU) 327/2011 (EN 17166)

		Actual	Req. 2015			
01 Overall efficiency η_{es}	%	31.1	28.7	09 Power consumption P_e	kW	0.16
02 Measurement category		A		09 Air flow q_v	m ³ /h	2245
03 Efficiency category		Static		09 Pressure increase p_{fs}	Pa	82
04 Efficiency grade N		42.4	40	10 Speed (rpm) n	min ⁻¹	1415
05 Variable speed drive		No		11 Specific ratio*		1.00

Data obtained at optimum efficiency level.

The ErP data is determined using a motor-impeller combination in a standardized measurement setup.

* Specific ratio = $1 + p_g / 100\,000\text{ Pa}$

LU-199640



Technical description

Weight	3.69 kg
Size	350 mm
Motor size	74
Rotor surface	Painted black
Blade material	PP plastic
Number of blades	5
Airflow direction	V
Direction of rotation	Counterclockwise, viewed toward rotor
Degree of protection	IP44; installation- and position-dependent as per EN 60034-5
Insulation class	"F"
Moisture (F) / Environmental (H) protection class	H1+
Max. permitted ambient temp. for motor (transport/storage)	+ 80 °C
Min. permitted ambient temp. for motor (transport/storage)	- 40 °C
Installation position	Shaft horizontal or rotor on bottom; rotor on top on request
Condensation drainage holes	On rotor side
Mode	S1
Motor bearing	Ball bearing
Touch current according to IEC 60990 (measuring circuit Fig. 4, TN system)	< 0.75 mA
Electrical hookup	Prepared for terminal box installation
Motor protection	Thermal overload protector (TOP) internally connected
With cable	Variable
Protection class	I (with customer connection of protective earth)
Conformity with standards	EN 60335-1; CE

AC axial fan

sickle-shaped blades (S series)

Product drawing

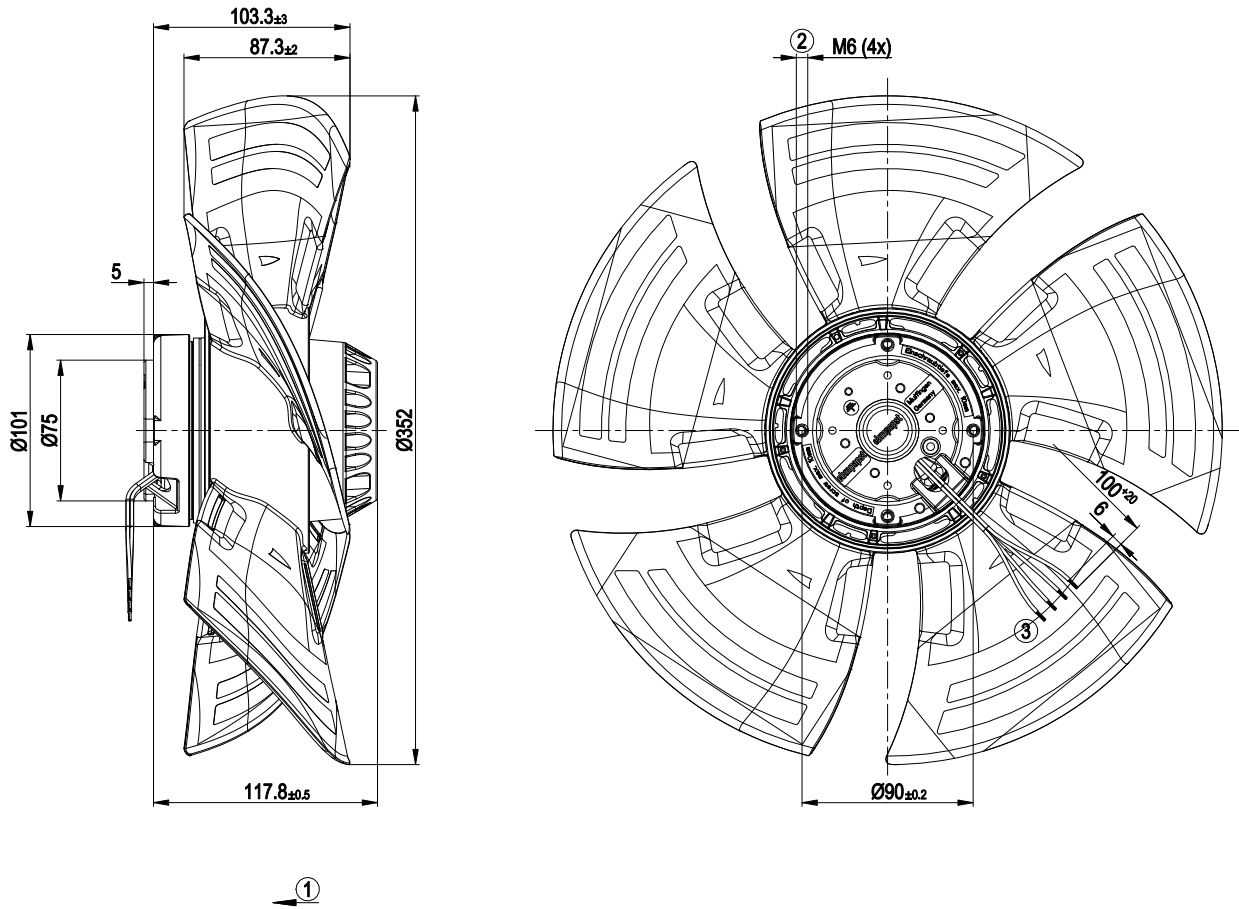

1	Direction of air flow "V"
2	Max. clearance for screw 10 mm
3	Cable halogen-silicone-free 4x 0.5 mm ² , 4x crimped splices

Connection diagram



U1	blue	Z	brown	U2	black
PE	green/yellow				



Curves: Air performance 50 Hz

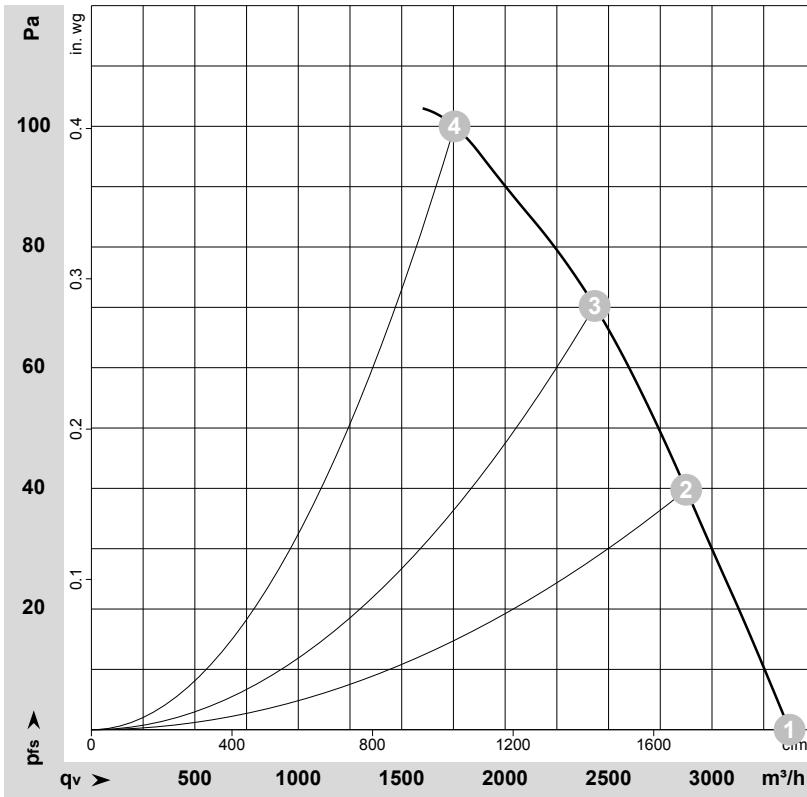

$\rho = 1.15 \text{ kg/m}^3 \pm 2 \%$

Measurement: LU-130206-1

Air performance measured according to ISO 5801 installation category A. For detailed information on the measurement setup, contact ebmpapst. Intake sound level: Sound power level according to ISO 13347 / sound pressure level measured at 1 m distance from fan axis. The values given are valid under the specified measuring conditions and may vary due to conditions of installation. For deviations from the standard configuration, the parameters have to be checked on the installed unit.

Measured values

	U	f	n	P _e	I	LpA _{in}	LwA _{in}	q _v	p _{fs}	q _v	p _{fs}
	V	Hz	min ⁻¹	W	A	dB(A)	dB(A)	m ³ /h	Pa	cfm	in. wg
1	230	50	1435	143	0.68	62	70	3375	0	1985	0.00
2	230	50	1425	157	0.73	59	67	2875	40	1690	0.16
3	230	50	1415	167	0.77	56	64	2435	70	1430	0.28
4	230	50	1400	180	0.81	65	73	1755	100	1035	0.40

U = Voltage · f = Frequency · n = Speed (rpm) · P_e = Power consumption · I = Current draw · LpA_{in} = Sound pressure level intake side · LwA_{in} = Sound power level intake side
 q_v = Air flow · p_{fs} = Pressure increase



Curves: Air performance 60 Hz

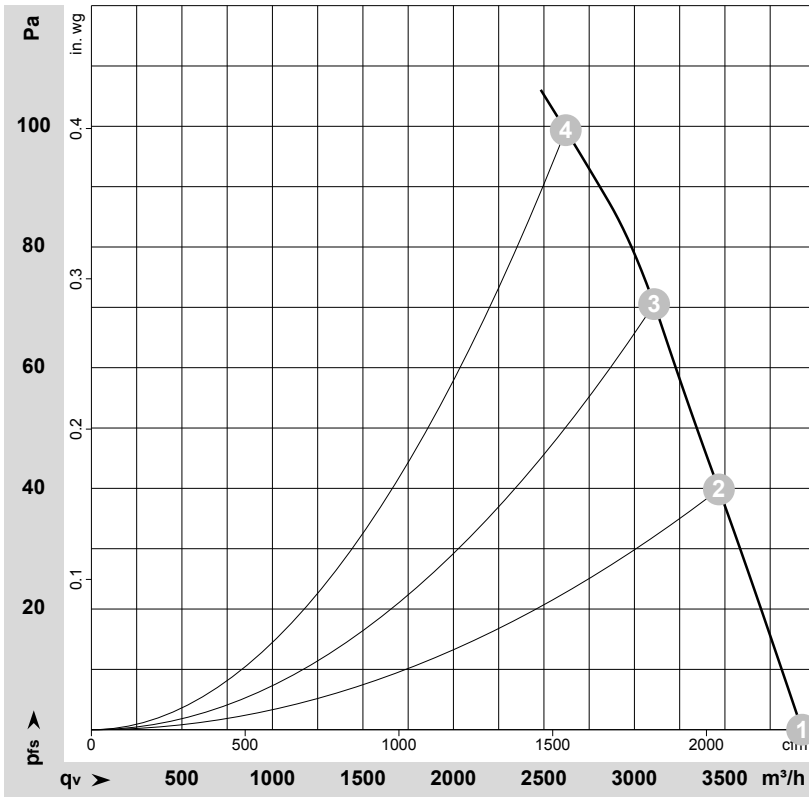

$\rho = 1.15 \text{ kg/m}^3 \pm 2 \%$

Measurement: LU-130207-1

Air performance measured according to ISO 5801 installation category A. For detailed information on the measurement setup, contact ebmpapst. Intake sound level: Sound power level according to ISO 13347 / sound pressure level measured at 1 m distance from fan axis. The values given are valid under the specified measuring conditions and may vary due to conditions of installation. For deviations from the standard configuration, the parameters have to be checked on the installed unit.

Measured values

	U	f	n	P _e	I	LpA _{in}	LwA _{in}	q _v	p _{fs}	q _v	p _{fs}
	V	Hz	min ⁻¹	W	A	dB(A)	dB(A)	m ³ /h	Pa	cfm	in. wg
1	230	60	1675	204	0.89	66	73	3925	0	2310	0.00
2	230	60	1650	224	0.98	63	71	3465	40	2040	0.16
3	230	60	1635	235	1.02	61	69	3110	70	1830	0.28
4	230	60	1600	250	1.10	60	68	2620	100	1545	0.40

U = Voltage · f = Frequency · n = Speed (rpm) · P_e = Power consumption · I = Current draw · LpA_{in} = Sound pressure level intake side · LwA_{in} = Sound power level intake side
 q_v = Air flow · p_{fs} = Pressure increase

