



A4E350-AN25-71 ebmpapst Datasheet

sales@fansco.com

www.fansco.com

Limited partnership · Headquarters Muldingen

Amtsgericht (court of registration) Stuttgart · HRA 590344

General partner Elektrobau Muldingen GmbH · Headquarters Muldingen

Amtsgericht (court of registration) Stuttgart · HRB 590142

Nominal data

Type	A4E350-AN25-71		
Motor	M4E074-DF		
Phase		1~	1~
Nominal voltage	VAC	115	115
Frequency	Hz	60	60
Method of obtaining data		ml	ml
Valid for approval/standard		CE	UL 2111
Speed (rpm)	min ⁻¹	1390	1500
Power consumption	W	205	200
Current draw	A	1.75	1.68
Capacitor	µF	16	16
Capacitor voltage	VDB	250	250
Capacitor standard		S0 (CE)	UL
Max. back pressure	Pa	55	55
Max. back pressure	inH ₂ O	0.22	0.22
Min. ambient temperature	°C	-25	-25
Max. ambient temperature	°C	40	40
Starting current	A	2.2	

ml = Max. load · me = Max. efficiency · fa = Free air · cs = Customer specification · ce = Customer equipment
Subject to change



Technical description

Weight	3.5 kg
Fan size	350 mm
Rotor surface	Painted black
Impeller material	PP plastic
Number of blades	5
Airflow direction	"A"
Direction of rotation	Clockwise, viewed toward rotor
Degree of protection	IP44; installation- and position-dependent as per EN 60034-5
Insulation class	"F"
Moisture (F) / Environmental (H) protection class	H0+
Max. permitted ambient temp. for motor (transport/storage)	+ 80 °C
Min. permitted ambient temp. for motor (transport/storage)	- 40 °C
Installation position	Shaft horizontal or rotor on bottom; rotor on top on request
Condensation drainage holes	On rotor side
Mode	S1
Motor bearing	Ball bearing
Touch current according to IEC 60990 (measuring circuit Fig. 4, TN system)	< 0.75 mA
Motor protection	Thermal overload protector (TOP) internally connected
With cable	Variable
Protection class	I (with customer connection of protective earth)
Conformity with standards	EN 60335-1; CE
Approval	CSA C22.2 No. 77; UL 2111

Product drawing

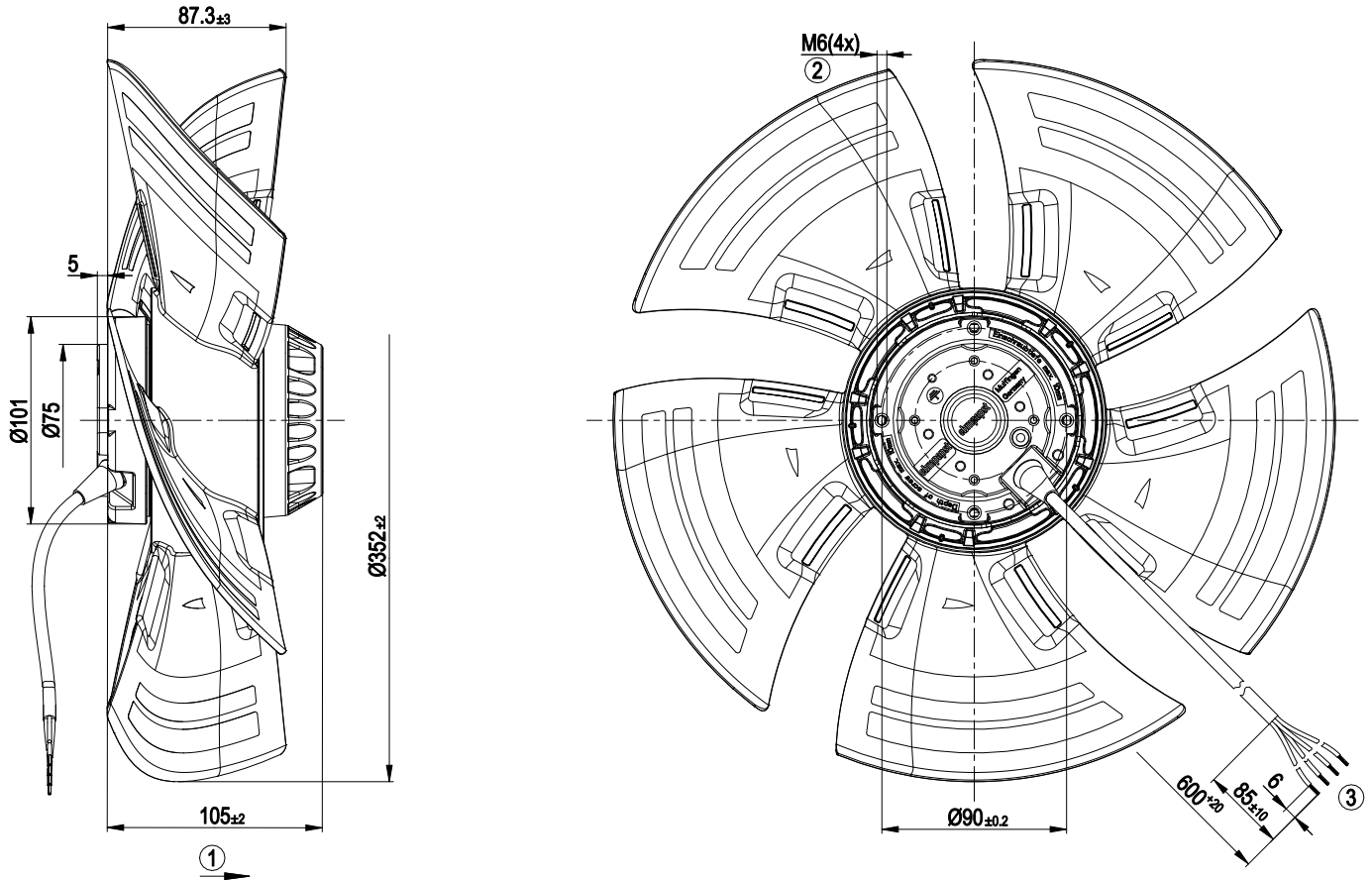

1	Direction of air flow "A"
2	Max. clearance for screw 10 mm
3	Cable PFA 4G, 4x crimped splices

Connection diagram



U1	blue	Z	brown	U2	black
PE	green/yellow				

Curves: Air performance 60 Hz

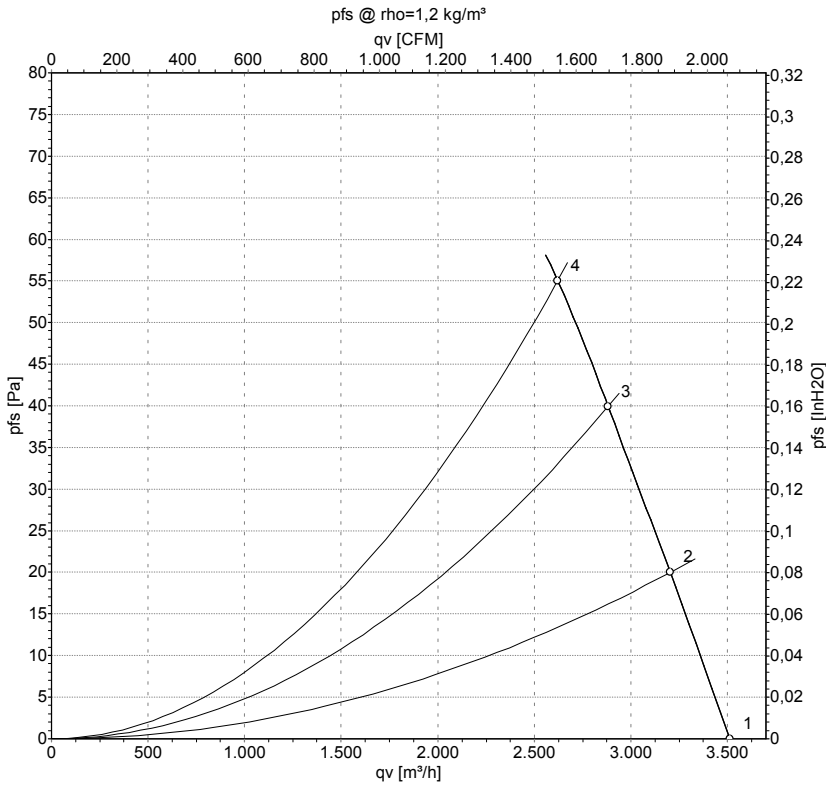

Measurement: LU-134885-1

Air performance measured according to ISO 5801 installation category A. For detailed information on the measurement setup, contact ebm-papst. Intake sound level: Sound power level according to ISO 13347 / sound pressure level measured at 1 m distance from fan axis. The values given are valid under the specified measuring conditions and may vary due to conditions of installation. For deviations from the standard configuration, the parameters have to be checked on the installed unit.

Measured values

	U	f	n	P _e	I	q _v	p _{fs}	q _v	p _{fs}
	V	Hz	min ⁻¹	W	A	m ³ /h	Pa	cfm	inH2O
1	115	60	1500	185	1.61	3510	0	2065	0.00
2	115	60	1465	192	1.66	3205	20	1885	0.08
3	115	60	1425	198	1.71	2885	40	1695	0.16
4	115	60	1390	205	1.75	2620	55	1545	0.22

U = Power supply · f = Frequency · n = Speed (rpm) · P_e = Power consumption · I = Current draw · q_v = Air flow · p_{fs} = Pressure increase

