

A4E350-AN19-32

# AC axial fan

sickle-shaped blades (S series)



A4E350-AN19-32 ebmpapst Datasheet FansCo

[sales@fansco.com](mailto:sales@fansco.com)

[www.fansco.com](http://www.fansco.com)

## Nominal data

Type	A4E350-AN19-32		
Motor	M4E074-DF		
Phase		1~	1~
Nominal voltage	VAC	230	230
Frequency	Hz	50	60
Method of obtaining data		ml	ml
Valid for approval/standard		-	-
Speed (rpm)	min <sup>-1</sup>	1270	1350
Power consumption	W	158	200
Current draw	A	0.70	0.88
Capacitor	µF	4	4
Capacitor voltage	VDB	400	400
Capacitor standard		S0 (CE)	S0 (CE)
Max. back pressure	Pa	80	60
Max. back pressure	in. wg	0.32	0.24
Min. ambient temperature	°C	-40	-40
Max. ambient temperature	°C	55	45
Starting current	A	1.1	1.11

ml = Max. load · me = Max. efficiency · fa = Free air · cs = Customer specification · ce = Customer equipment  
Subject to change

### Technical description

<b>Weight</b>	3.4 kg
<b>Size</b>	350 mm
<b>Motor size</b>	74
<b>Rotor surface</b>	Painted black
<b>Blade material</b>	PP plastic
<b>Number of blades</b>	5
<b>Airflow direction</b>	V
<b>Direction of rotation</b>	Counterclockwise, viewed toward rotor
<b>Degree of protection</b>	IP44; installation- and position-dependent as per EN 60034-5. The degree of protection is only assured when the intended cable guard and terminal box are installed.
<b>Insulation class</b>	"F"
<b>Moisture (F) / Environmental (H) protection class</b>	F2-2; H1+
<b>Max. permitted ambient temp. for motor (transport/storage)</b>	+ 80 °C
<b>Min. permitted ambient temp. for motor (transport/storage)</b>	- 40 °C
<b>Installation position</b>	Shaft horizontal or rotor on bottom; rotor on top on request
<b>Condensation drainage holes</b>	On rotor side
<b>Mode</b>	S1
<b>Motor bearing</b>	Ball bearing with low-temperature lubricant
<b>Touch current according to IEC 60990 (measuring circuit Fig. 4, TN system)</b>	< 0.75 mA
<b>Electrical hookup</b>	Prepared for terminal box installation
<b>Motor protection</b>	Thermal overload protector (TOP) internally connected
<b>With cable</b>	Variable
<b>Protection class</b>	I (with customer connection of protective earth)
<b>Conformity with standards</b>	EN 60335-1

## Product drawing

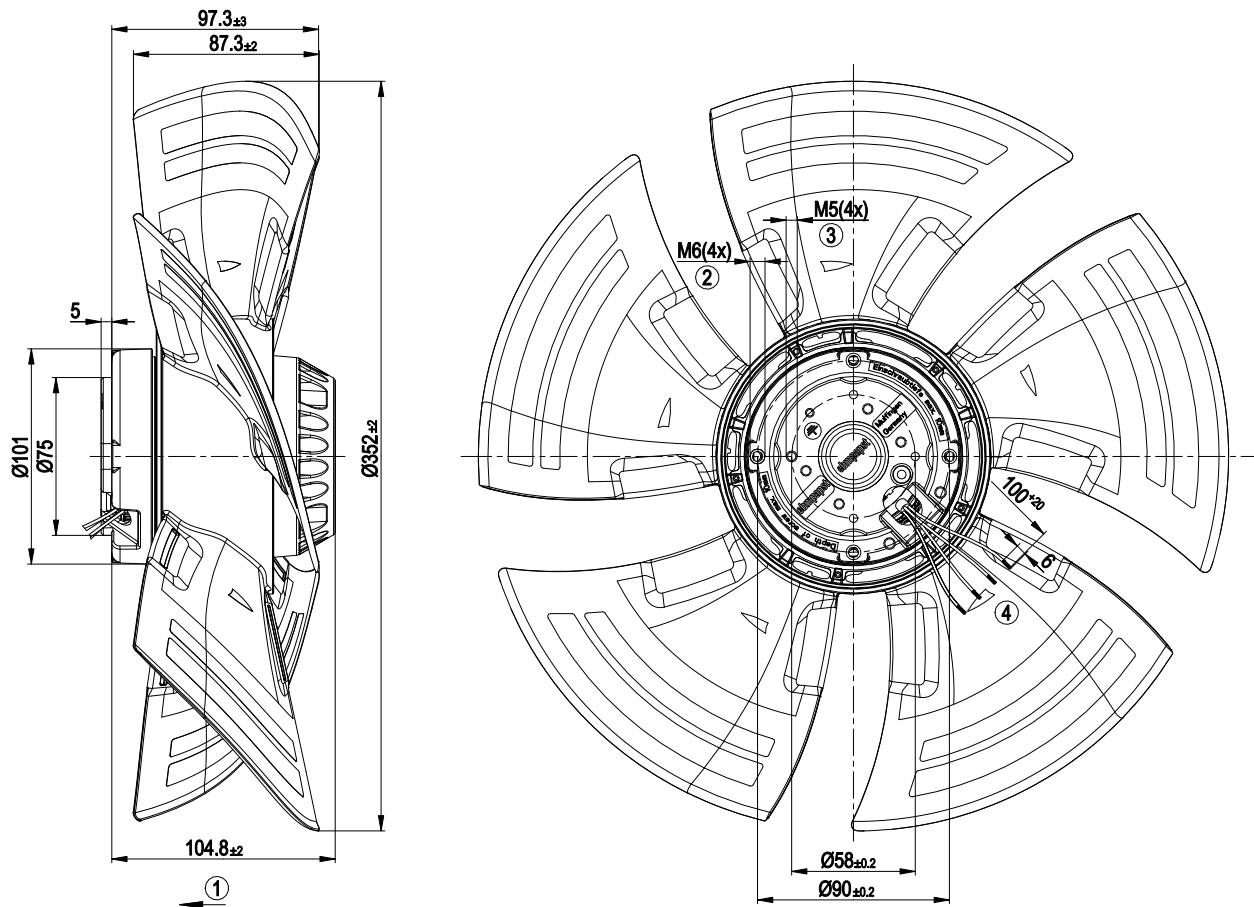

1	Direction of air flow "V"
2	Max. clearance for screw 10 mm
3	Max. clearance for screw 8 mm
4	Cable Dipotherm 4G 0.5 mm <sup>2</sup> , 4x crimped splices

## Connection diagram

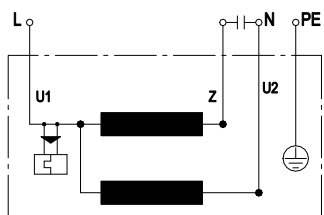

U1	blue	Z	brown	U2	black
PE	green/yellow				

## Curves: Air performance 50 Hz

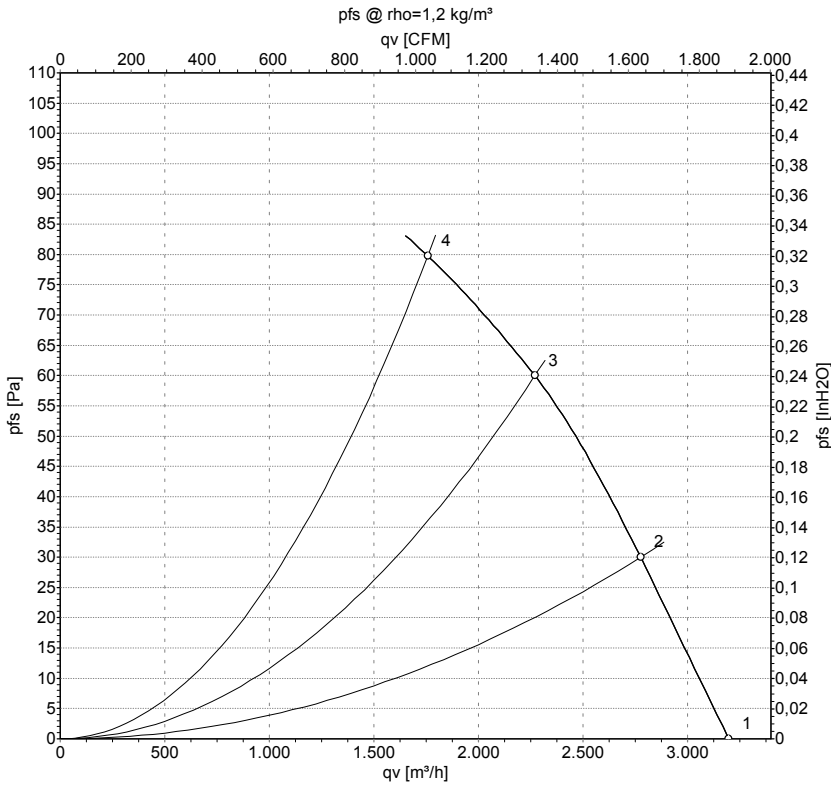

Measurement: LU-134319-1

Air performance measured according to ISO 5801 installation category A. For detailed information on the measurement setup, contact ebm-papst. Intake sound level: Sound power level according to ISO 13347 / sound pressure level measured at 1 m distance from fan axis. The values given are valid under the specified measuring conditions and may vary due to conditions of installation. For deviations from the standard configuration, the parameters have to be checked on the installed unit.

## Measured values

	U	f	n	P <sub>e</sub>	I	q <sub>v</sub>	p <sub>fs</sub>	q <sub>v</sub>	p <sub>fs</sub>
	V	Hz	min <sup>-1</sup>	W	A	m <sup>3</sup> /h	Pa	cfm	in. wg
1	230	50	1355	134	0.60	3200	0	1885	0.00
2	230	50	1330	142	0.63	2775	30	1635	0.12
3	230	50	1305	151	0.66	2270	60	1335	0.24
4	230	50	1270	158	0.70	1760	80	1035	0.32

U = Voltage · f = Frequency · n = Speed (rpm) · P<sub>e</sub> = Power consumption · I = Current draw · q<sub>v</sub> = Air flow · p<sub>fs</sub> = Pressure increase

## Curves: Air performance 60 Hz

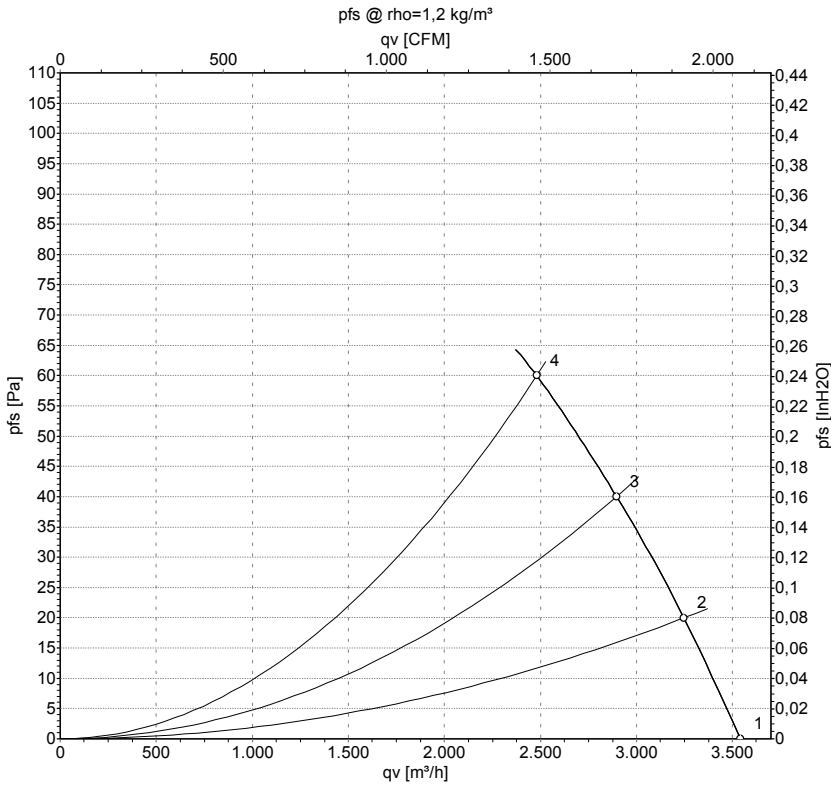

Measurement: LU-134321-1

Air performance measured according to ISO 5801 installation category A. For detailed information on the measurement setup, contact ebm-papst. Intake sound level: Sound power level according to ISO 13347 / sound pressure level measured at 1 m distance from fan axis. The values given are valid under the specified measuring conditions and may vary due to conditions of installation. For deviations from the standard configuration, the parameters have to be checked on the installed unit.

## Measured values

	U	f	n	P <sub>e</sub>	I	q <sub>v</sub>	p <sub>fs</sub>	q <sub>v</sub>	p <sub>fs</sub>
	V	Hz	min <sup>-1</sup>	W	A	m <sup>3</sup> /h	Pa	cfm	in. wg
1	230	60	1500	183	0.80	3540	0	2085	0.00
2	230	60	1465	189	0.82	3245	20	1910	0.08
3	230	60	1420	194	0.84	2895	40	1705	0.16
4	230	60	1350	200	0.88	2480	60	1460	0.24

U = Voltage · f = Frequency · n = Speed (rpm) · P<sub>e</sub> = Power consumption · I = Current draw · q<sub>v</sub> = Air flow · p<sub>fs</sub> = Pressure increase