

A4E350-AA06-53 ebmpapst Datasheet

sales@fansco.com

www.fansco.com

Nominal data

Type	A4E350-AA06-53			
Motor	M4E068-EC			
Phase		1~	1~	1~
Nominal voltage	VAC	230	230	230
Frequency	Hz	50	60	60
Method of obtaining data		fa	fa	fa
Valid for approval/standard		CE	CE	UL
Speed (rpm)	min ⁻¹	1390	1550	1550
Power consumption	W	140	195	205
Current draw	A	0.62	0.86	0.9
Capacitor	μF	5	5	5
Capacitor voltage	VDB	400	400	400
Capacitor standard		P0 (CE)	P0 (CE)	UL
Max. back pressure	Pa	120	90	90
Max. back pressure	inH ₂ O	0.48	0.36	0.36
Min. ambient temperature	°C	-25	-25	-25
Max. ambient temperature	°C	70	50	50
Starting current	A	1.4	1.3	1.3

ml = Max. load · me = Max. efficiency · fa = Free air · cs = Customer specification · ce = Customer equipment
Subject to change

Data according to ErP Directive

		Actual	Req. 2015
01 Overall efficiency η_{es}	%	28.5	28.5
02 Measurement category		A	
03 Efficiency category		Static	
04 Efficiency grade N		40	40
05 Variable speed drive		No	

Data obtained at optimum efficiency level.

The ErP data is determined using a motor-impeller combination in a standardized measurement setup.

09 Power consumption P_e	kW	0.15
09 Air flow q_v	m ³ /h	1880
09 Pressure increase p_{fs}	Pa	80
10 Speed (rpm) n	min ⁻¹	1360
11 Specific ratio*		1.00

* Specific ratio = $1 + p_g / 100\,000\text{ Pa}$

LU-64421



AC axial fan

straight blades (A series)

Technical description

Weight	3 kg
Fan size	350 mm
Rotor surface	Painted black
Impeller material	Sheet steel, hot-dip galvanized
Number of blades	5
Airflow direction	"V"
Direction of rotation	Counterclockwise, viewed toward rotor
Degree of protection	IP44
Insulation class	"F"
Moisture (F) / Environmental (H) protection class	H0+
Max. permitted ambient temp. for motor (transport/storage)	+ 80 °C
Min. permitted ambient temp. for motor (transport/storage)	- 40 °C
Installation position	Shaft horizontal or rotor on bottom; rotor on top on request
Condensation drainage holes	On rotor side
Mode	S1
Motor bearing	Ball bearing
Touch current according to IEC 60990 (measuring circuit Fig. 4, TN system)	< 0.75 mA
Motor protection	Thermal overload protector (TOP) internally connected
With cable	Lateral
Protection class	I (with customer connection of protective earth)
Conformity with standards	EN 60335-1; CE



Product drawing

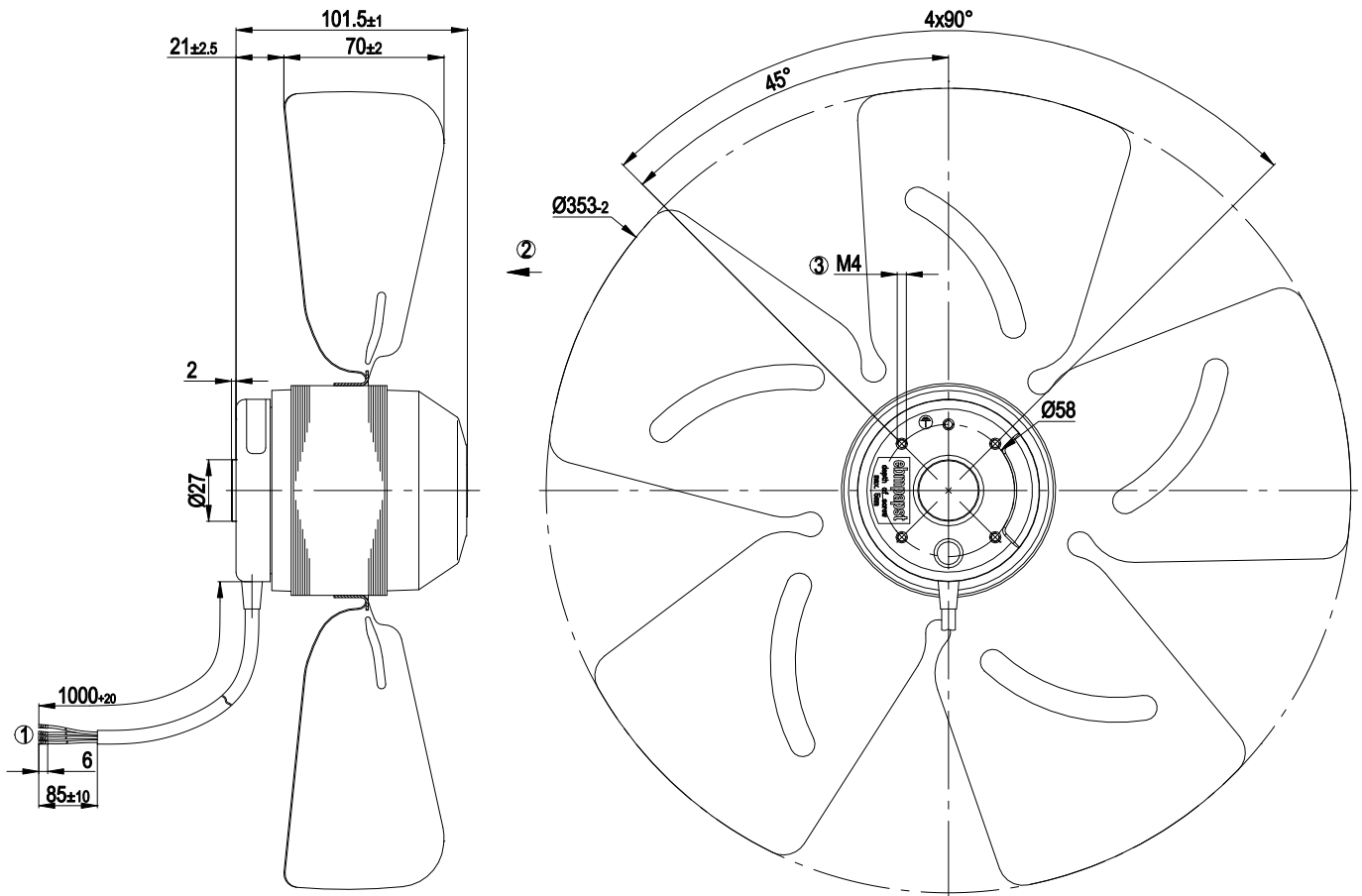

1	Cable silicone, crimped splices
2	Direction of air flow "V"
3	Direction of rotation counterclockwise, viewed toward rotor

Connection diagram

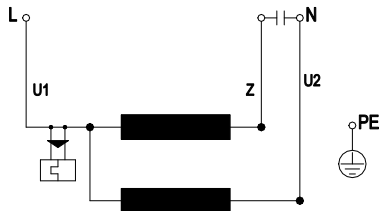

U1	blue	Z	brown	U2	black
PE	green/yellow				

Curves: Air performance 50 Hz

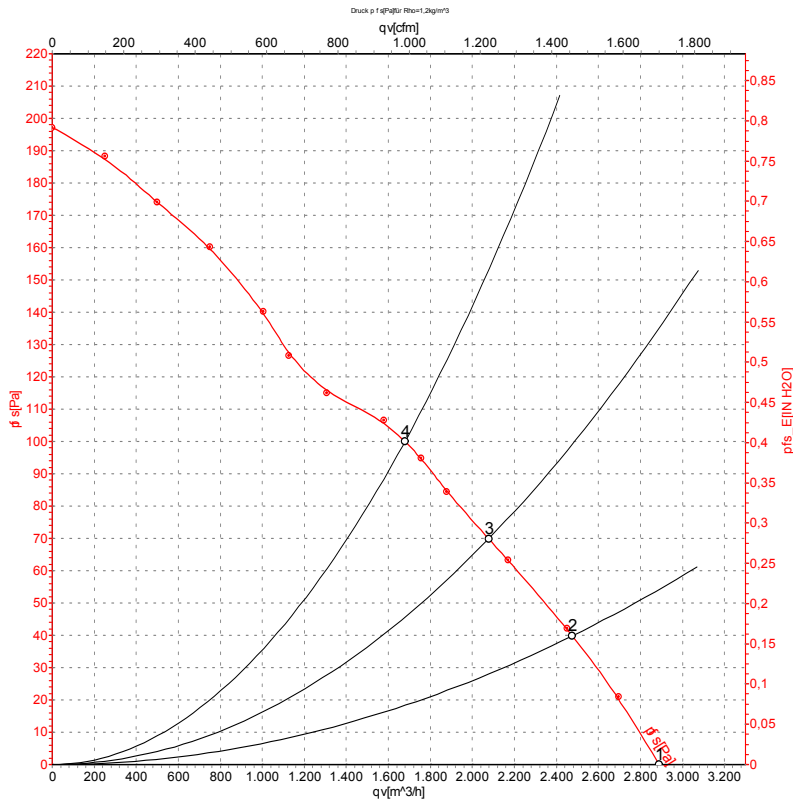

Measurement: LU-64421-1

Air performance measured according to ISO 5801 installation category A. For detailed information on the measurement setup, contact ebm-papst. Intake sound level: Sound power level according to ISO 13347 / sound pressure level measured at 1 m distance from fan axis. The values given are valid under the specified measuring conditions and may vary due to conditions of installation. For deviations from the standard configuration, the parameters have to be checked on the installed unit.

Measured values

	U	f	n	P _e	I	qv	p _{fs}	qv	p _{fs}
	V	Hz	min ⁻¹	W	A	m ³ /h	Pa	CFM	inH ₂ O
1	230	50	1390	140	0.62	2890	0	1700	0.00
2	230	50	1370	143	0.63	2475	40	1455	0.16
3	230	50	1360	149	0.65	2080	70	1225	0.28
4	230	50	1330	167	0.73	1680	100	990	0.40

U = Power supply · f = Frequency · n = Speed (rpm) · P_e = Power consumption · I = Current draw · qv = Air flow · p_{fs} = Pressure increase



Curves: Air performance 60 Hz

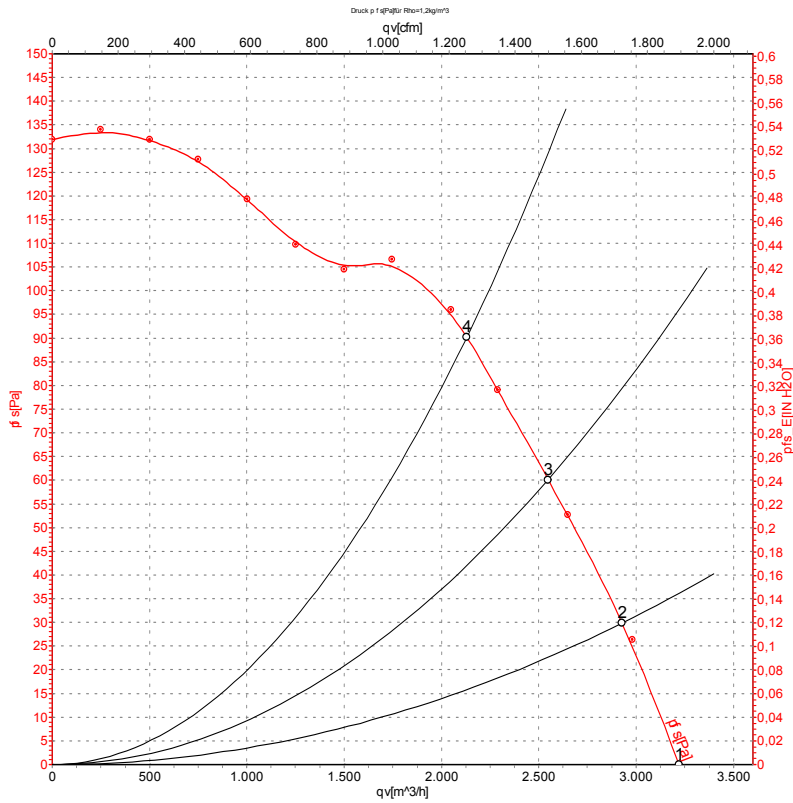

Measurement: LU-64461-1

Air performance measured according to ISO 5801 installation category A. For detailed information on the measurement setup, contact ebm-papst. Intake sound level: Sound power level according to ISO 13347 / sound pressure level measured at 1 m distance from fan axis. The values given are valid under the specified measuring conditions and may vary due to conditions of installation. For deviations from the standard configuration, the parameters have to be checked on the installed unit.

Measured values

	U	f	n	P _e	I	qv	p _{fs}	qv	p _{fs}
	V	Hz	min ⁻¹	W	A	m ³ /h	Pa	CFM	inH ₂ O
1	230	60	1550	195	0.86	3220	0	1895	0.00
2	230	60	1520	202	0.88	2925	30	1725	0.12
3	230	60	1495	210	0.91	2550	60	1500	0.24
4	230	60	1475	216	0.94	2130	90	1255	0.36

U = Power supply · f = Frequency · n = Speed (rpm) · P_e = Power consumption · I = Current draw · qv = Air flow · p_{fs} = Pressure increase

