

AC axial fan

sickled blades (S series)

A4E330-AP20-21 ebmpapst Datasheet FansCo

sales@fansco.com

www.fansco.com

Nominal data

Type	A4E330-AP20-21		
Motor	M4E068-DF		
Phase		1~	1~
Nominal voltage	VAC	230	230
Frequency	Hz	50	60
Type of data definition		fa	fa
Valid for approval / standard		CE	CE
Speed (rpm)	min ⁻¹	1360	1520
Power input	W	105	135
Current draw	A	0.52	0.6
Motor capacitor	µF	3	3
Capacitor voltage	VDB	400	400
Capacitor standard		S0 (CE)	S0 (CE)
Max. back pressure	Pa	60	70
Min. ambient temperature	°C	-25	-25
Max. ambient temperature	°C	45	45

ml = Max. load · me = Max. efficiency · fa = Running at free air · cs = Customer specs · cu = Customer unit
Subject to alterations



Technical features

Mass	2.6 kg
Size	330 mm
Surface of rotor	Coated in black
Material of blades	Sheet steel, coated in black
Number of blades	5
Direction of air flow	"V"
Direction of rotation	Counter-clockwise, seen on rotor
Type of protection	IP 44; Depending on installation and position as per EN 60034-5
Insulation class	"B"
Humidity (F)/environmental protection class (H)	H0+
Max. permissible ambient motor temp. (transp./ storage)	+ 80 °C
Min. permissible ambient motor temp. (transp./storage)	- 40 °C
Mounting position	Any
Condensate discharge holes	Rotor-side
Operation mode	S1
Motor bearing	Ball bearing
Touch current acc. IEC 60990 (measuring network Fig. 4, TN system)	< 0.75 mA
Motor protection	Thermal overload protector (TOP) wired internally
Cable exit	Axial
Protection class	I (if protective earth is connected by customer)
Product conforming to standard	EN 60335-1; CE



Product drawing

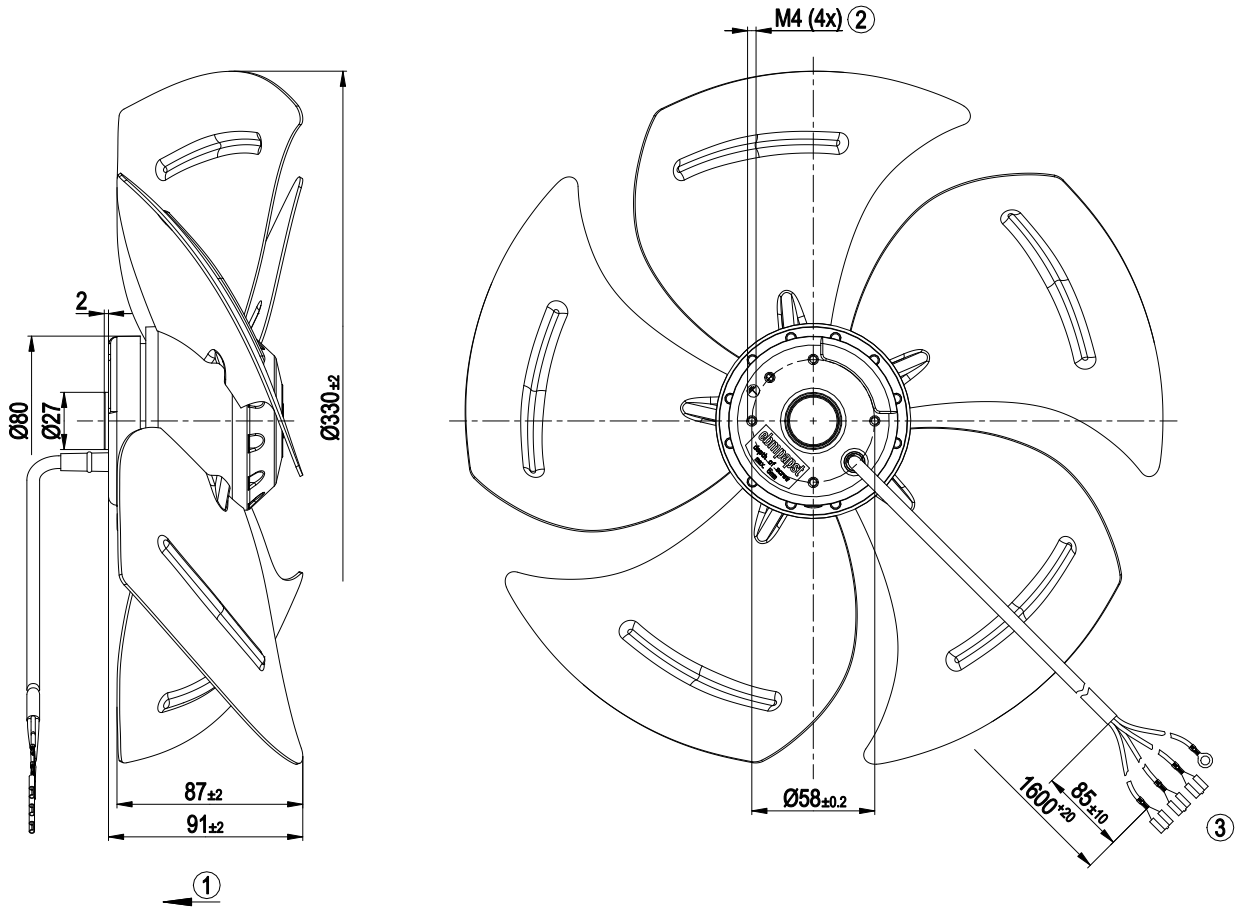

1	Direction of air flow "V"
2	Thread reach max. 5 mm
3	Connection line PVC 4G 0.5 mm ² , 3x threaded pin 6.3x0.8, 1x contact stud Ø 4.3

Connection screen

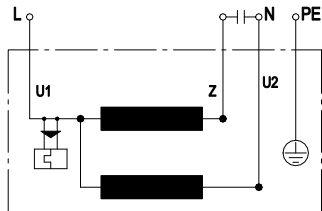

U1	blue	Z	brown	U2	black
PE	green/yellow				



Charts: Air flow 50 Hz

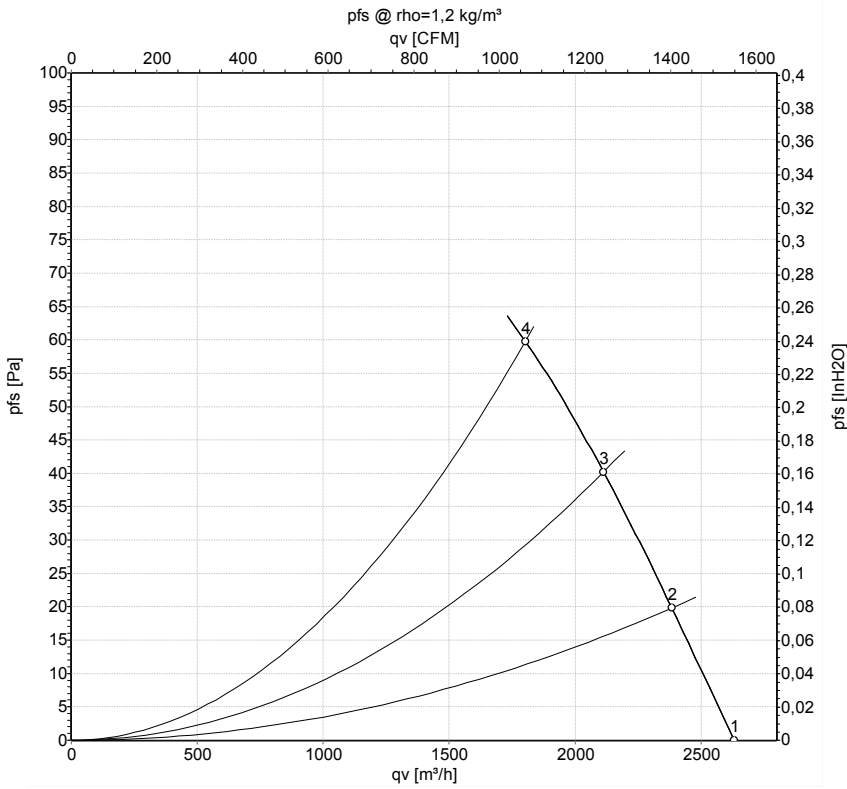

Measurement: LU-160750-1

Air performance measured as per ISO 5801 Installation category A. For detailed information on the measuring set-up, please contact ebm-papst. Suction-side noise levels: L_{wA} measured as per ISO 13347 / L_{pA} measured with 1m distance to fan axis. The values given are valid under the measuring conditions mentioned above and may vary according to the actual installation situation. With any deviation from the standard set-up, the specific values have to be checked and reviewed with the unit installed.

Measured values

	U	f	n	P _e	I	L _{pA_{in}}	L _{wA_{in}}	q _v	p _{fs}	q _v	p _{fs}
	V	Hz	min ⁻¹	W	A	dB(A)	dB(A)	m ³ /h	Pa	cfm	inH ₂ O
1	230	50	1360	105	0.52	65	72	2630	0	1550	0.00
2	230	50	1345	113	0.54	64	71	2385	20	1405	0.08
3	230	50	1330	118	0.55	63	70	2115	40	1245	0.16
4	230	50	1315	123	0.57	62	68	1800	60	1060	0.24

U = Supply voltage · f = Frequency · n = Speed (rpm) · P_e = Power input · I = Current draw · L_{pA_{in}} = Sound pressure level inlet side · L_{wA_{in}} = Sound power level inlet side · q_v = Air flow
 p_{fs} = Pressure increase



Charts: Air flow 60 Hz

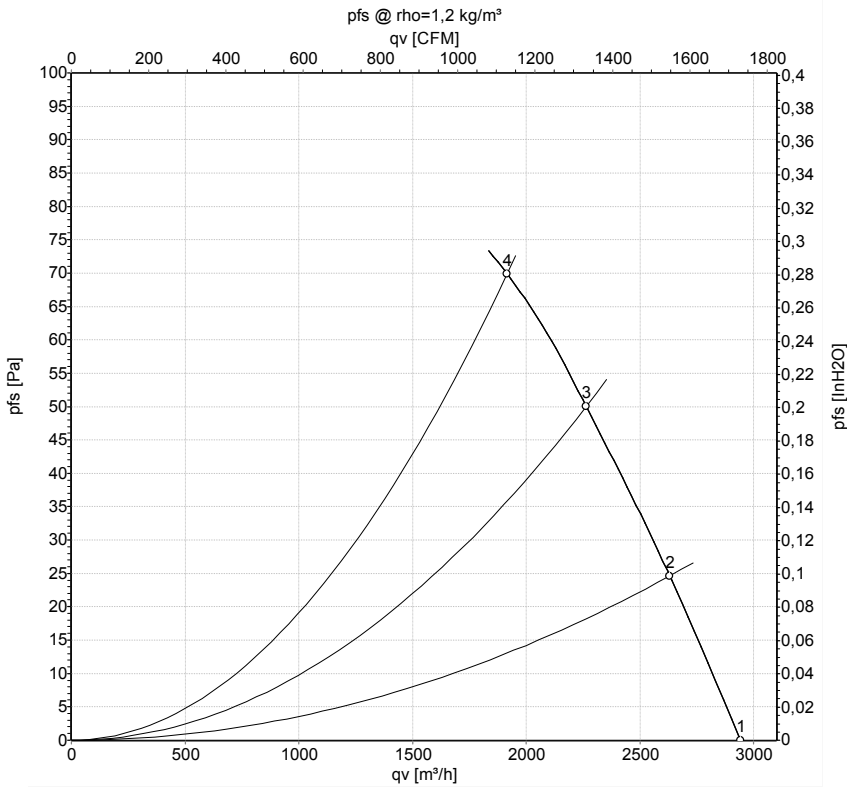

Measurement: LU-160973-1

Air performance measured as per ISO 5801 Installation category A. For detailed information on the measuring set-up, please contact ebm-papst. Suction-side noise levels: L_{wA} measured as per ISO 13347 / L_{pA} measured with 1m distance to fan axis. The values given are valid under the measuring conditions mentioned above and may vary according to the actual installation situation. With any deviation from the standard set-up, the specific values have to be checked and reviewed with the unit installed.

Measured values

	U	f	n	P_e	I	$L_{pA_{in}}$	$L_{wA_{in}}$	q_v	p_{fs}	q_v	p_{fs}
	V	Hz	min^{-1}	W	A	dB(A)	dB(A)	$\text{m}^3\text{/h}$	Pa	cfm	inH2O
1	230	60	1520	135	0.60	68	75	2940	0	1730	0.00
2	230	60	1480	148	0.65	66	73	2630	25	1550	0.10
3	230	60	1445	158	0.69	65	71	2265	50	1330	0.20
4	230	60	1405	164	0.72	63	70	1915	70	1125	0.28

U = Supply voltage · f = Frequency · n = Speed (rpm) · P_e = Power input · I = Current draw · $L_{pA_{in}}$ = Sound pressure level inlet side · $L_{wA_{in}}$ = Sound power level inlet side · q_v = Air flow
 p_{fs} = Pressure increase

