

AC axial fan

sickle-shaped blades (S series), single-intake
with support ring

A4E330-AP18-18 ebmpapst Datasheet

sales@fansco.com

www.fansco.com

Limited partnership · Headquarters Mulfingen

Amtsgericht (court of registration) Stuttgart · HRA 590344

General partner Elektrobau Mulfingen GmbH · Headquarters Mulfingen

Amtsgericht (court of registration) Stuttgart · HRB 590142

Nominal data

Type	A4E330-AP18-18		
Motor	M4E068-DF		
Phase		1~	1~
Nominal voltage	VAC	230	230
Frequency	Hz	50	60
Method of obtaining data		fa	fa
Valid for approval/standard		-	-
Speed (rpm)	min ⁻¹	1390	1600
Power consumption	W	120	140
Current draw	A	0.57	0.61
Capacitor	µF	4	4
Capacitor voltage	VDB	400	400
Capacitor standard		S0 (CE)	S0 (CE)
Max. back pressure	Pa	90	75
Max. back pressure	inH ₂ O	0.36	0.3
Min. ambient temperature	°C	-25	-25
Max. ambient temperature	°C	40	40
Starting current	A	1.4	1.3

ml = Max. load · me = Max. efficiency · fa = Free air · cs = Customer specification · ce = Customer equipment
Subject to change



AC axial fan

sickle-shaped blades (S series), single-intake
with support ring

Technical description

Weight	2.5 kg
Fan size	330 mm
Rotor surface	Painted black
Blade material	Sheet steel, painted black
Number of blades	5
Airflow direction	"V"
Direction of rotation	Counterclockwise, viewed toward rotor
Degree of protection	IP44; installation- and position-dependent as per EN 60034-5
Insulation class	"B"
Moisture (F) / Environmental (H) protection class	F3-1
Max. permitted ambient temp. for motor (transport/storage)	+ 80 °C
Min. permitted ambient temp. for motor (transport/storage)	- 40 °C
Installation position	Any
Condensation drainage holes	On rotor side
Mode	S1
Motor bearing	Ball bearing
Touch current according to IEC 60990 (measuring circuit Fig. 4, TN system)	< 0.75 mA
Motor protection	Thermal overload protector (TOP) internally connected
With cable	Axial
Protection class	I (with customer connection of protective earth)
Conformity with standards	EN 60335-1
Approval	CCC



AC axial fan

sickle-shaped blades (S series), single-intake
with support ring

Product drawing

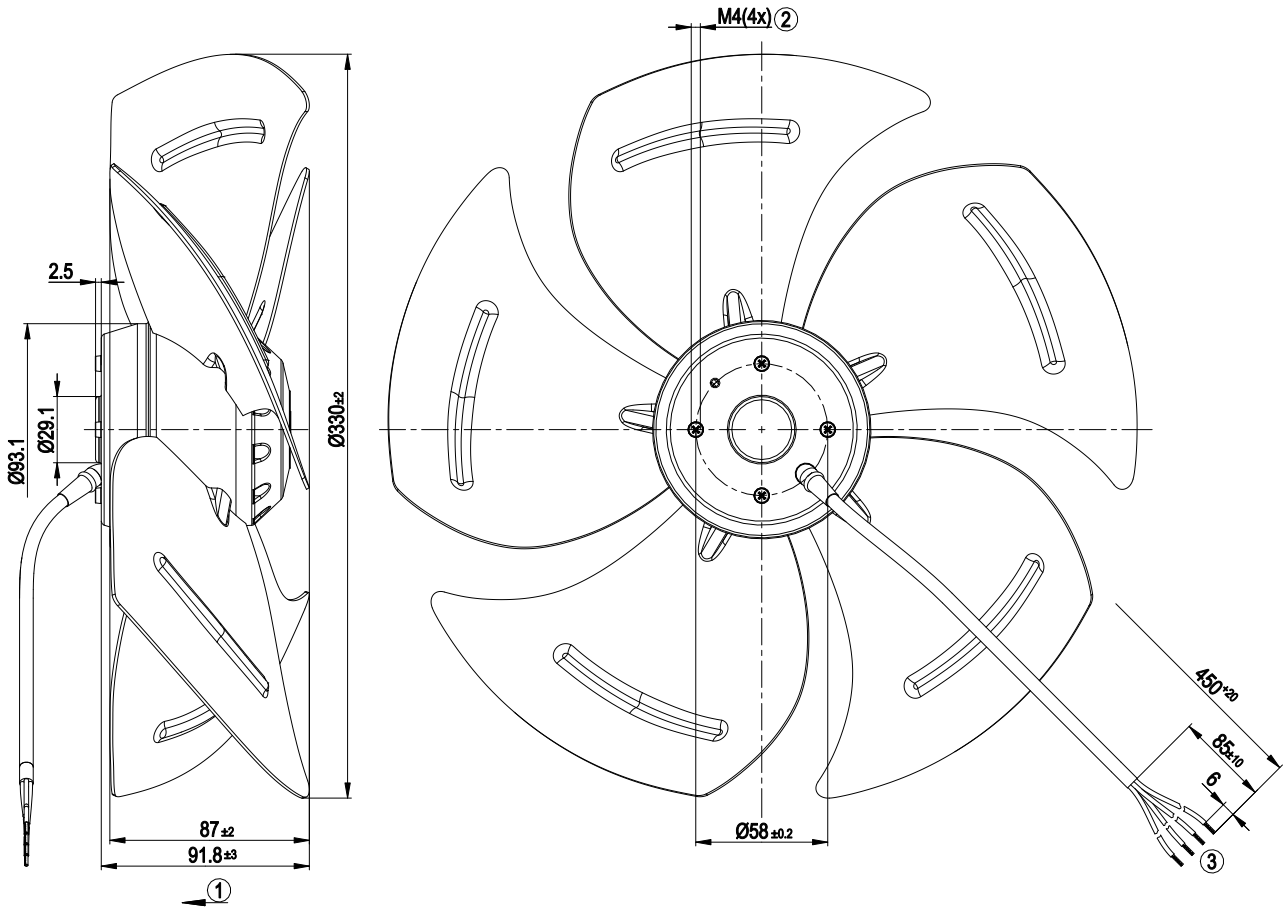

1	Direction of air flow "V"
2	Max. clearance for screw 5 mm
3	Cable silicone 4G 0.5 mm ² , 4x crimped splices

Connection diagram

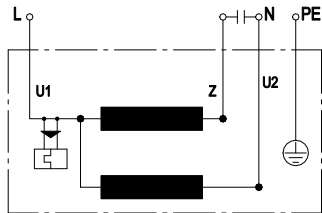

U1	blue	Z	brown	U2	black
PE	green/yellow				



AC axial fan

sickle-shaped blades (S series), single-intake
with support ring

Curves: Air performance 50 Hz

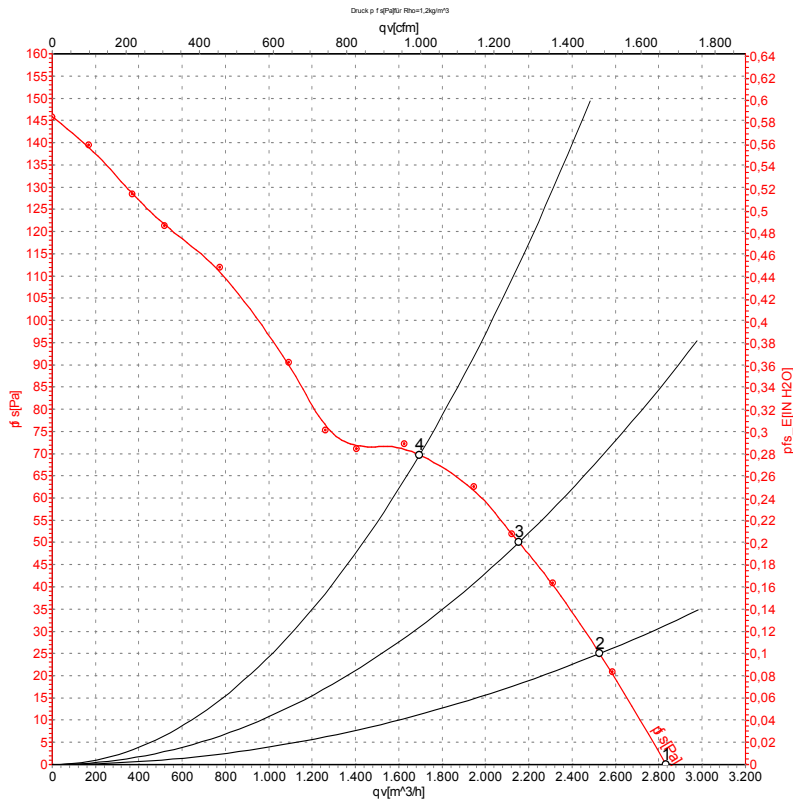

Measurement: LU-32943-1

Air performance measured according to ISO 5801 installation category A. For detailed information on the measurement setup, contact ebmpapst. Intake sound level: Sound power level according to ISO 13347 / sound pressure level measured at 1 m distance from fan axis. The values given are valid under the specified measuring conditions and may vary due to conditions of installation. For deviations from the standard configuration, the parameters have to be checked on the installed unit.

Measured values

	U	f	n	P _e	I	q _v	P _{fs}	q _v	P _{fs}
	V	Hz	min ⁻¹	W	A	m ³ /h	Pa	cfm	inH2O
1	230	50	1390	120	0.57	2835	0	1670	0.00
2	230	50	1375	122	0.58	2525	25	1485	0.10
3	230	50	1355	130	0.61	2155	50	1270	0.20
4	230	50	1330	140	0.64	1695	70	1000	0.28

U = Power supply · f = Frequency · n = Speed (rpm) · P_e = Power consumption · I = Current draw · q_v = Air flow · P_{fs} = Pressure increase



AC axial fan

sickle-shaped blades (S series), single-intake
with support ring

Curves: Air performance 60 Hz

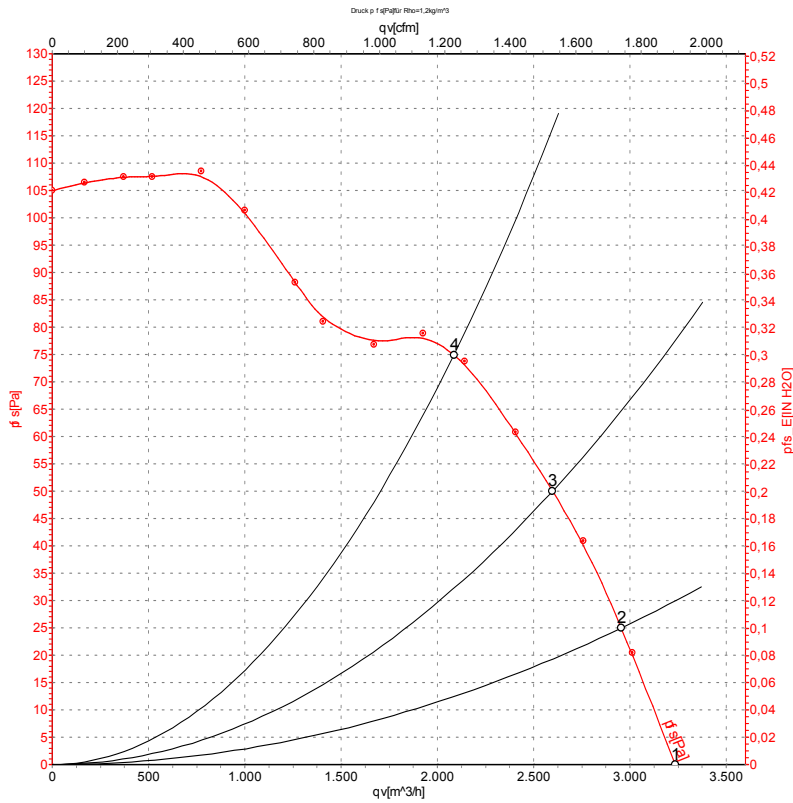

Measurement: LU-32944-1

Air performance measured according to ISO 5801 installation category A. For detailed information on the measurement setup, contact ebmpapst. Intake sound level: Sound power level according to ISO 13347 / sound pressure level measured at 1 m distance from fan axis. The values given are valid under the specified measuring conditions and may vary due to conditions of installation. For deviations from the standard configuration, the parameters have to be checked on the installed unit.

Measured values

	U	f	n	P _e	I	q _v	p _{fs}	q _v	p _{fs}
	V	Hz	min ⁻¹	W	A	m ³ /h	Pa	cfm	inH ₂ O
1	230	60	1600	140	0.61	3235	0	1905	0.00
2	230	60	1575	150	0.65	2955	25	1740	0.10
3	230	60	1530	163	0.71	2600	50	1530	0.20
4	230	60	1470	179	0.78	2085	75	1230	0.30

U = Power supply · f = Frequency · n = Speed (rpm) · P_e = Power consumption · I = Current draw · q_v = Air flow · p_{fs} = Pressure increase

