

AC axial fan

straight blades (A series)

A4E330-AB16-20 ebmpapst Datasheet
 sales@fansco.com
 www.fansco.com

Limited partnership · Headquarters Muldingen
 Amtsgericht (court of registration) Stuttgart · HRA 590344
 General partner Elektrobau Muldingen GmbH · Headquarters Muldingen
 Amtsgericht (court of registration) Stuttgart · HRB 590142

Nominal data

Type	A4E330-AB16-20		
Motor	M4E068-DF		
Phase		1~	1~
Nominal voltage	VAC	230	230
Frequency	Hz	50	60
Method of obtaining data		fa	fa
Valid for approval/standard		CE	CE
Speed (rpm)	min ⁻¹	1350	1500
Power consumption	W	100	140
Current draw	A	0.45	0.62
Capacitor	µF	4	4
Capacitor voltage	VDB	400	400
Capacitor standard		S0 (CE)	S0 (CE)
Max. back pressure	Pa	75	80
Max. back pressure	inH ₂ O	0.3	0.32
Min. ambient temperature	°C	-25	-25
Max. ambient temperature	°C	65	45
Starting current	A	0.86	0.81

ml = Max. load · me = Max. efficiency · fa = Free air · cs = Customer specification · ce = Customer equipment
 Subject to change



Technical description

Weight	2.4 kg
Fan size	330 mm
Rotor surface	Painted black
Blade material	Sheet steel, painted black
Number of blades	5
Airflow direction	"V"
Direction of rotation	Counterclockwise, viewed toward rotor
Degree of protection	IP44; installation- and position-dependent as per EN 60034-5
Insulation class	"F"
Moisture (F) / Environmental (H) protection class	F2-2
Max. permitted ambient temp. for motor (transport/storage)	+ 80 °C
Min. permitted ambient temp. for motor (transport/storage)	- 40 °C
Installation position	Shaft horizontal or rotor on bottom; rotor on top on request
Condensation drainage holes	On rotor side
Mode	S1
Motor bearing	Ball bearing
Touch current according to IEC 60990 (measuring circuit Fig. 4, TN system)	< 0.75 mA
Electrical hookup	With plug
Motor protection	Thermal overload protector (TOP) internally connected
With cable	Axial
Protection class	I (with customer connection of protective earth)
Conformity with standards	EN 60335-1; CE

Product drawing

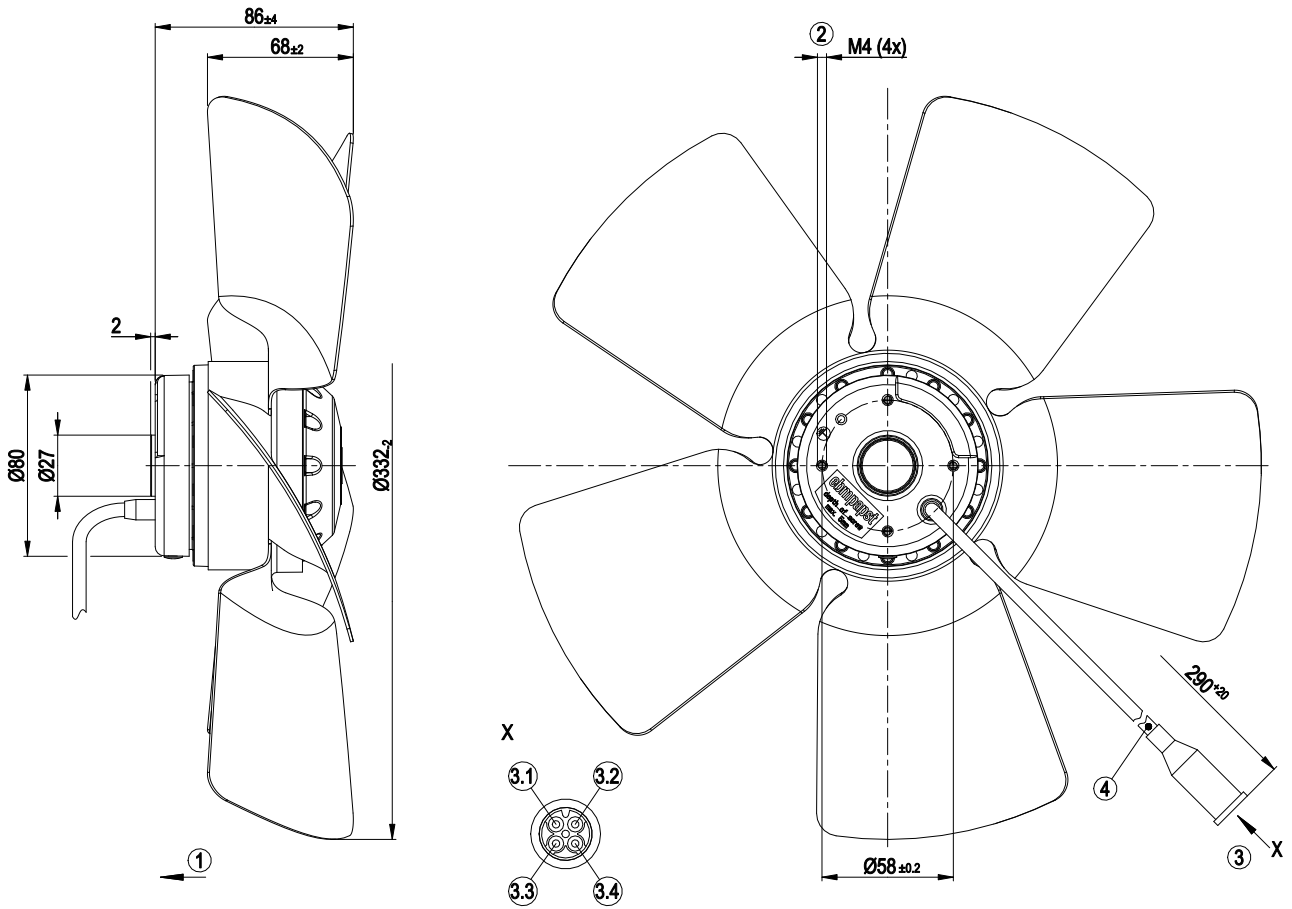

1	Direction of air flow "V"
2	Max. clearance for screw 5 mm
3	Cable silicone 4G 0.5 mm ² , 4-pole connector housing tyco 925075-7 with insulating sleeve, 4x plug pin tyco 163555-8
3.1	Z (brown)
3.2	N (black)
3.3	PE (green/yellow)
3.4	L (blue)
4	Red marking

Connection diagram

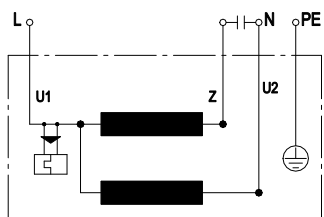

U1	blue	Z	brown	U2	black
PE	green/yellow				

Curves: Air performance 50 Hz

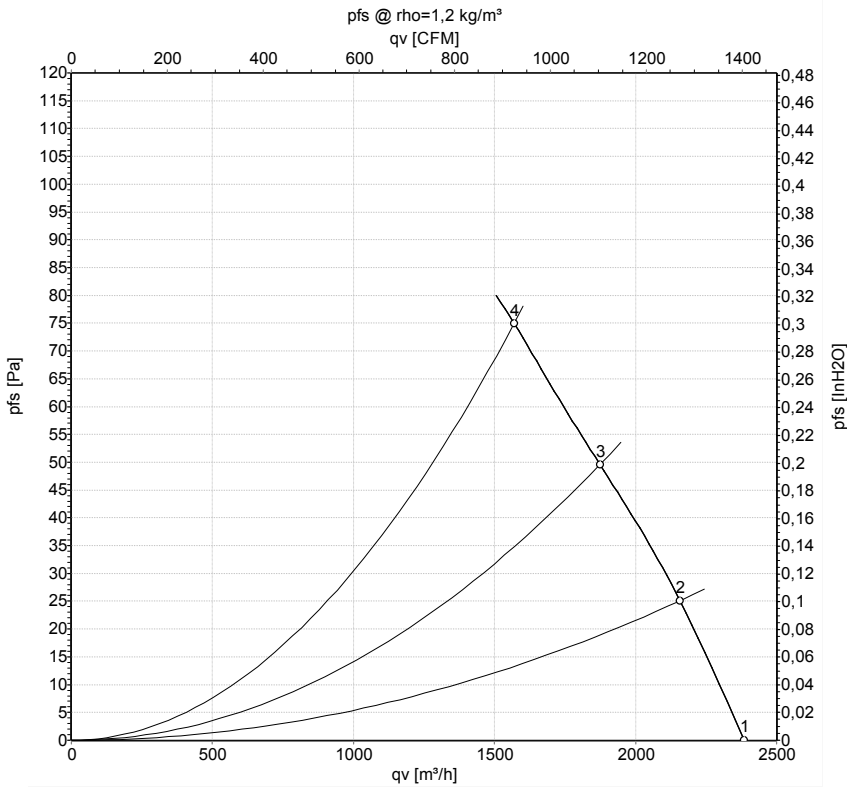

Measurement: LU-160751-1

Air performance measured according to ISO 5801 installation category A. For detailed information on the measurement setup, contact ebm-papst. Intake sound level: Sound power level according to ISO 13347 / sound pressure level measured at 1 m distance from fan axis. The values given are valid under the specified measuring conditions and may vary due to conditions of installation. For deviations from the standard configuration, the parameters have to be checked on the installed unit.

Measured values

	U	f	n	P _e	I	LpA _{in}	LwA _{in}	q _v	p _{fs}	q _v	p _{fs}
	V	Hz	min ⁻¹	W	A	dB(A)	dB(A)	m ³ /h	Pa	cfm	inH ₂ O
1	230	50	1350	100	0.45	66	73	2385	0	1405	0.00
2	230	50	1335	108	0.47	65	72	2160	25	1270	0.10
3	230	50	1315	113	0.49	62	68	1875	50	1105	0.20
4	230	50	1295	119	0.52	56	63	1570	75	925	0.30

U = Power supply · f = Frequency · n = Speed (rpm) · P_e = Power consumption · I = Current draw · LpA_{in} = Sound pressure level intake side · LwA_{in} = Sound power level intake side
 q_v = Air flow · p_{fs} = Pressure increase



Curves: Air performance 60 Hz

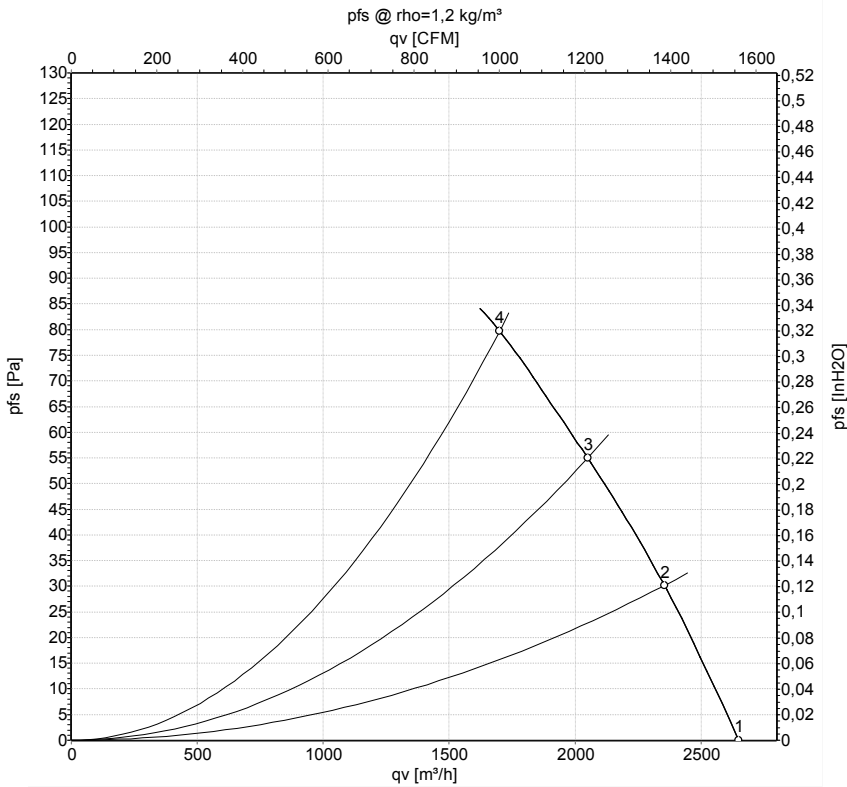

Measurement: LU-160967-1

Air performance measured according to ISO 5801 installation category A. For detailed information on the measurement setup, contact ebm-papst. Intake sound level: Sound power level according to ISO 13347 / sound pressure level measured at 1 m distance from fan axis. The values given are valid under the specified measuring conditions and may vary due to conditions of installation. For deviations from the standard configuration, the parameters have to be checked on the installed unit.

Measured values

	U	f	n	P _e	I	LpA _{in}	LwA _{in}	q _v	p _{fs}	q _v	p _{fs}
	V	Hz	min ⁻¹	W	A	dB(A)	dB(A)	m ³ /h	Pa	cfm	inH ₂ O
1	230	60	1500	140	0.62	69	75	2650	0	1560	0.00
2	230	60	1450	150	0.66	67	74	2355	30	1385	0.12
3	230	60	1415	156	0.69	64	70	2050	55	1205	0.22
4	230	60	1375	159	0.70	59	66	1700	80	1000	0.32

U = Power supply · f = Frequency · n = Speed (rpm) · P_e = Power consumption · I = Current draw · LpA_{in} = Sound pressure level intake side · LwA_{in} = Sound power level intake side
 q_v = Air flow · p_{fs} = Pressure increase

