

A4E315-AC08-09

AC axial fan

straight blades (A series)



A4E315-AC08-09 ebmpapst Datasheet
sales@fansco.com
www.fansco.com

Limited partnership · Headquarters Muldingen
Amtsgericht (court of registration) Stuttgart · HRA 590344

General partner Elektrobau Muldingen GmbH · Headquarters Muldingen
Amtsgericht (court of registration) Stuttgart · HRB 590142

Nominal data

Type	A4E315-AC08-09		
Motor	M4E068-DF		
Phase		1~	1~
Nominal voltage	VAC	230	230
Frequency	Hz	50	60
Method of obtaining data		fa	fa
Valid for approval/standard		CE	CE
Speed (rpm)	min ⁻¹	1370	1530
Power consumption	W	95	135
Current draw	A	0.42	0.6
Capacitor	µF	3	3
Capacitor voltage	VDB	400	400
Capacitor standard		S0 (CE)	S0 (CE)
Max. back pressure	Pa	75	65
Max. back pressure	inH2O	0.3	0.26
Min. ambient temperature	°C	-40	-40
Max. ambient temperature	°C	40	40

ml = Max. load · me = Max. efficiency · fa = Free air · cs = Customer specification · ce = Customer equipment
Subject to change



Technical description

Weight	2.5 kg
Fan size	315 mm
Rotor surface	Painted black
Blade material	Sheet steel, painted black
Number of blades	5
Airflow direction	"V"
Direction of rotation	Counterclockwise, viewed toward rotor
Degree of protection	IP44; installation- and position-dependent as per EN 60034-5
Insulation class	"B"
Moisture (F) / Environmental (H) protection class	F2-2
Max. permitted ambient temp. for motor (transport/storage)	+ 80 °C
Min. permitted ambient temp. for motor (transport/storage)	- 40 °C
Installation position	Shaft horizontal or rotor on bottom; rotor on top on request
Condensation drainage holes	On rotor side
Mode	S1
Motor bearing	Ball bearing with low-temperature lubricant
Touch current according to IEC 60990 (measuring circuit Fig. 4, TN system)	< 0.75 mA
Motor protection	Thermal overload protector (TOP) internally connected
With cable	Variable
Protection class	I (with customer connection of protective earth)
Conformity with standards	EN 60335-1; CE
Approval	CCC

Product drawing

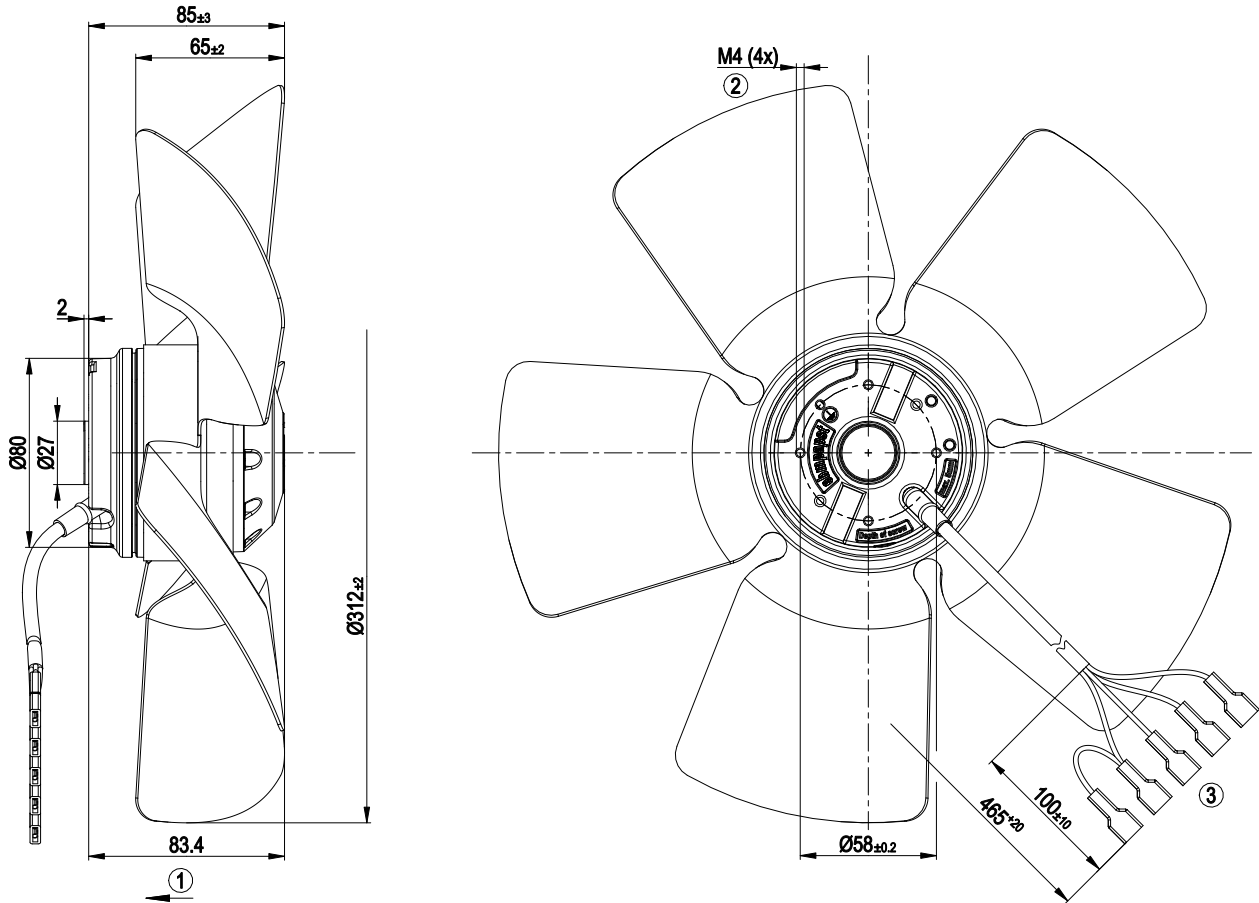

1	Direction of air flow "V"
2	Max. clearance for screw 5 mm
3	Cable silicone 4G 0.5 mm ² , 5x flat push-on receptacle 6.3 x 0.8 with insulating sleeve crimped

Connection diagram

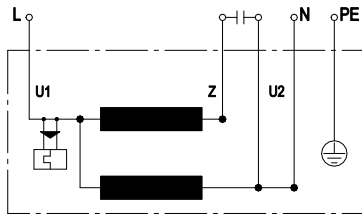

L	blue	Z	brown	U2	black
N	black	PE	green/yellow		

Curves: Air performance 50 Hz

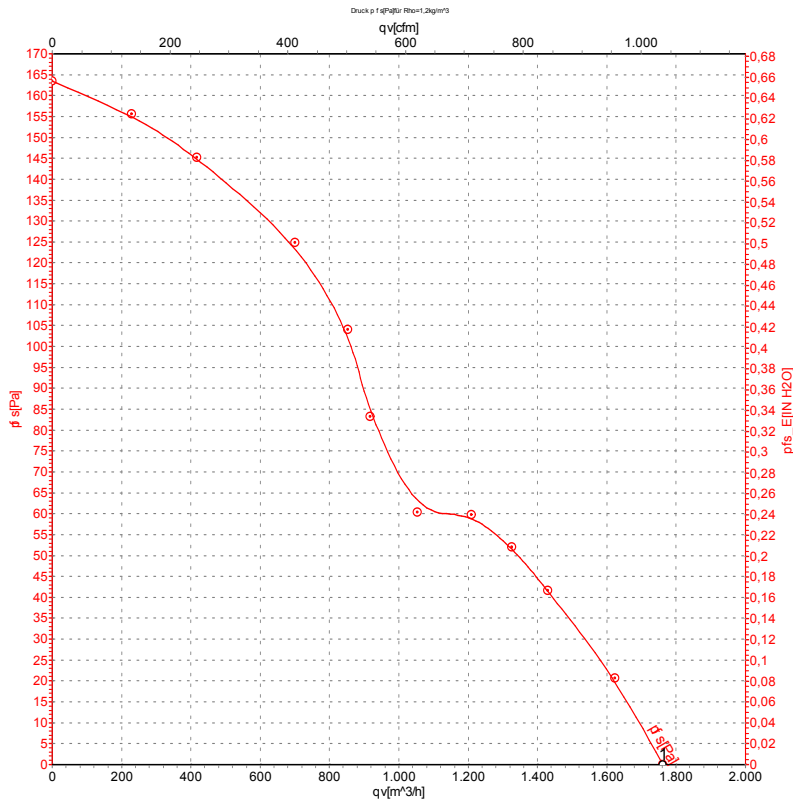

Measurement: LU-37061-1

Air performance measured according to ISO 5801 installation category A. For detailed information on the measurement setup, contact ebm-papst. Intake sound level: Sound power level according to ISO 13347 / sound pressure level measured at 1 m distance from fan axis. The values given are valid under the specified measuring conditions and may vary due to conditions of installation. For deviations from the standard configuration, the parameters have to be checked on the installed unit.

Measured values

	U	f	n	P _e	I	q _v	q _v	P _{fs}
	V	Hz	min ⁻¹	W	A	m ³ /h	cfm	inH ₂ O
1	230	50	1370	95	0.42	1760	1035	0.00

U = Power supply · f = Frequency · n = Speed (rpm) · P_e = Power consumption · I = Current draw · q_v = Air flow



Curves: Air performance 60 Hz

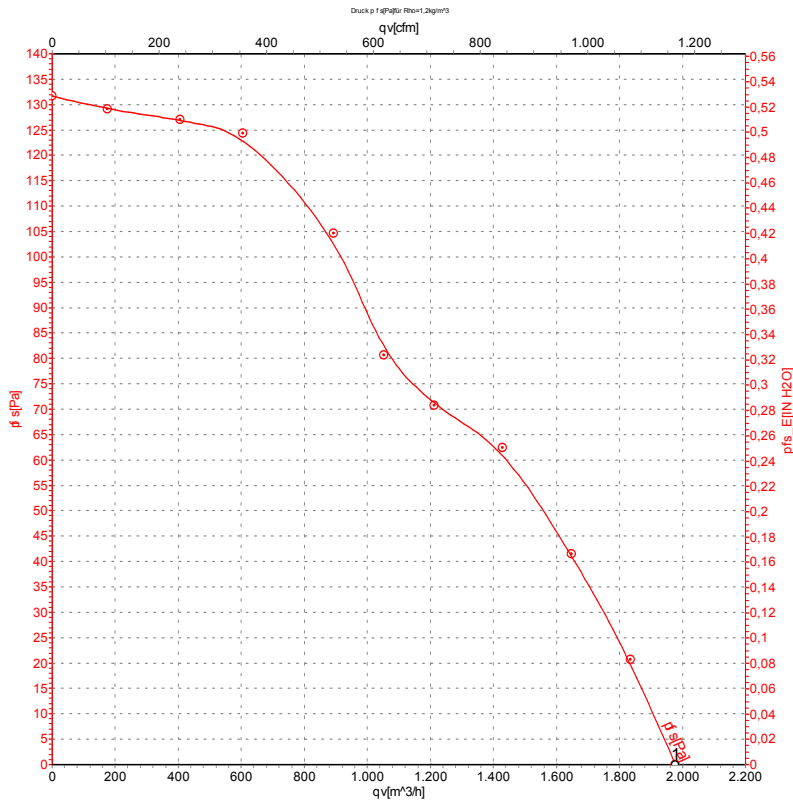

Measurement: LU-37062-1

Air performance measured according to ISO 5801 installation category A. For detailed information on the measurement setup, contact ebm-papst. Intake sound level: Sound power level according to ISO 13347 / sound pressure level measured at 1 m distance from fan axis. The values given are valid under the specified measuring conditions and may vary due to conditions of installation. For deviations from the standard configuration, the parameters have to be checked on the installed unit.

Measured values

	U	f	n	P _e	I	q _v	q _v	P _{fs}
	V	Hz	min ⁻¹	W	A	m ³ /h	cfm	inH2O
1	230	60	1530	135	0.60	1970	1160	0.00

U = Power supply · f = Frequency · n = Speed (rpm) · P_e = Power consumption · I = Current draw · q_v = Air flow

