

A4E300-AU20-08 ebmpapst Datasheet

sales@fansco.com

www.fansco.com

Limited partnership · Headquarters Mulfingen

Amtsgericht (court of registration) Stuttgart · HRA 590344

General partner Elektrobau Mulfingen GmbH · Headquarters Mulfingen

Amtsgericht (court of registration) Stuttgart · HRB 590142

## Nominal data

|                             |                    |         |         |
|-----------------------------|--------------------|---------|---------|
| Type                        | A4E300-AU20-08     |         |         |
| Motor                       | M4E068-BF          |         |         |
| Phase                       |                    | 1~      | 1~      |
| Nominal voltage             | VAC                | 230     | 230     |
| Frequency                   | Hz                 | 50      | 60      |
| Method of obtaining data    |                    | ml      | ml      |
| Valid for approval/standard |                    | CE      | CE      |
| Speed (rpm)                 | min <sup>-1</sup>  | 1070    | 1140    |
| Power consumption           | W                  | 52      | 58      |
| Current draw                | A                  | 0.24    | 0.27    |
| Capacitor                   | µF                 | 1.5     | 1.5     |
| Capacitor voltage           | VDB                | 400     | 400     |
| Capacitor standard          |                    | S0 (CE) | S0 (CE) |
| Max. back pressure          | Pa                 | 35      | 35      |
| Max. back pressure          | inH <sub>2</sub> O | 0.14    | 0.14    |
| Min. ambient temperature    | °C                 | -25     | -25     |
| Max. ambient temperature    | °C                 | 45      | 50      |

ml = Max. load · me = Max. efficiency · fa = Free air · cs = Customer specification · ce = Customer equipment  
Subject to change



### Technical description

|  |  |
|--|--|
| Fan size   | 300 mm   |
| Rotor surface  | Painted black  |
| Blade material   | PP-GF40 plastic  |
| Number of blades   | 5  |
| Airflow direction  | "A"  |
| Direction of rotation  | Clockwise, viewed toward rotor                               |
| Degree of protection   | IP44; installation- and position-dependent as per EN 60034-5 |
| Insulation class   | "B"  |
| Moisture (F) / Environmental (H) protection class                          | H0+  |
| Max. permitted ambient temp. for motor (transport/storage)                 | + 80 °C  |
| Min. permitted ambient temp. for motor (transport/storage)                 | - 40 °C  |
| Installation position  | Shaft horizontal or rotor on bottom; rotor on top on request |
| Condensation drainage holes  | On rotor side  |
| Mode   | S1   |
| Motor bearing  | Ball bearing   |
| Touch current according to IEC 60990 (measuring circuit Fig. 4, TN system) | < 0.75 mA  |
| Motor protection   | Thermal overload protector (TOP) internally connected        |
| With cable   | Variable   |
| Protection class   | I (with customer connection of protective earth)             |
| Conformity with standards  | EN 60335-1; CE   |
| Approval   | CCC  |

## Product drawing

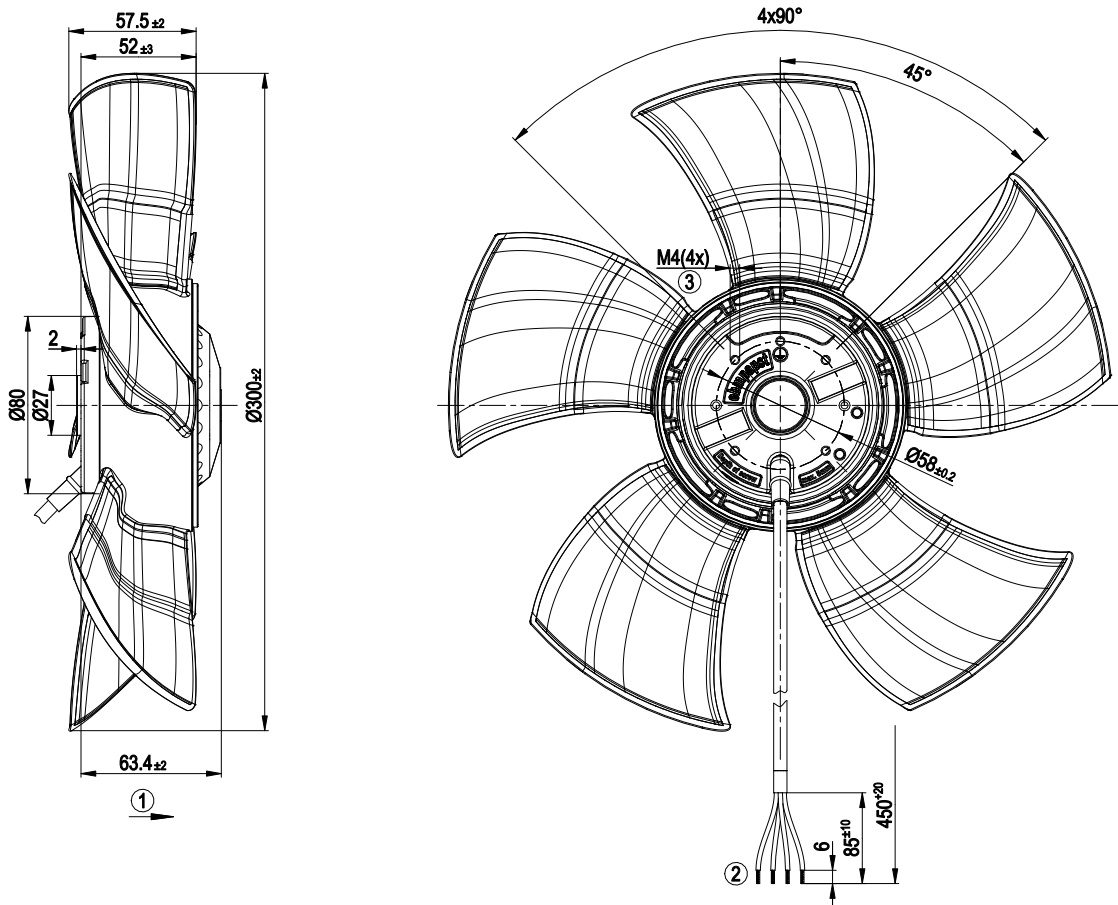

|   |   |
|---|---|
| 1 | Direction of air flow "A"                             |
| 2 | Cable PVC 4G 0.5 mm <sup>2</sup> , 4x crimped splices |
| 3 | Max. clearance for screw 5 mm                         |

## Connection diagram

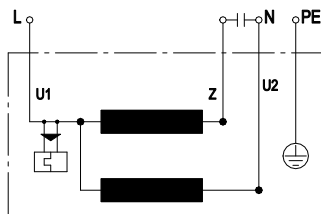

|    |              |   |       |    |       |
|----|--------------|---|-------|----|-------|
| U1 | blue         | Z | brown | U2 | black |
| PE | green/yellow |   |       |    |       |

## Curves: Air performance 50 Hz

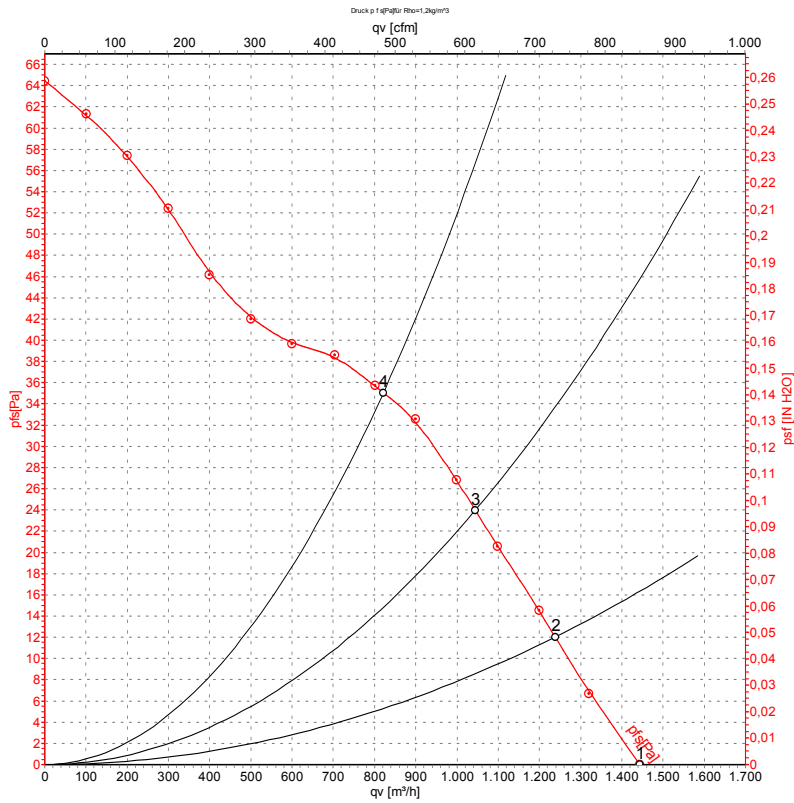

Measurement: LU-122750-1

Air performance measured according to ISO 5801 installation category A. For detailed information on the measurement setup, contact ebmpapst. Intake sound level: Sound power level according to ISO 13347 / sound pressure level measured at 1 m distance from fan axis. The values given are valid under the specified measuring conditions and may vary due to conditions of installation. For deviations from the standard configuration, the parameters have to be checked on the installed unit.

## Measured values

|   | U   | f  | n                 | P <sub>e</sub> | I    | q <sub>v</sub>    | p <sub>fs</sub> | q <sub>v</sub> | p <sub>fs</sub>    |
|---|-----|----|-------------------|----------------|------|-------------------|-----------------|----------------|--------------------|
|   | V   | Hz | min <sup>-1</sup> | W              | A    | m <sup>3</sup> /h | Pa              | cfm            | inH <sub>2</sub> O |
| 1 | 230 | 50 | 1150              | 48             | 0.22 | 1445              | 0               | 850            | 0.00               |
| 2 | 230 | 50 | 1145              | 49             | 0.22 | 1240              | 12              | 730            | 0.05               |
| 3 | 230 | 50 | 1120              | 50             | 0.22 | 1045              | 24              | 615            | 0.10               |
| 4 | 230 | 50 | 1085              | 51             | 0.23 | 820               | 35              | 485            | 0.14               |

U = Power supply · f = Frequency · n = Speed (rpm) · P<sub>e</sub> = Power consumption · I = Current draw · q<sub>v</sub> = Air flow · p<sub>fs</sub> = Pressure increase



## Curves: Air performance 60 Hz

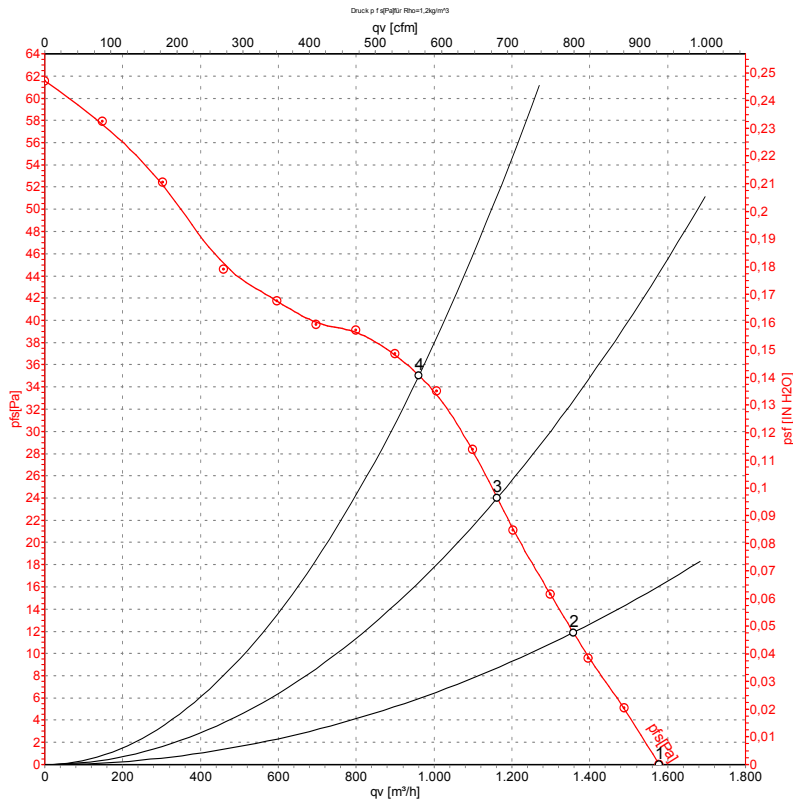

Measurement: LU-122751-1

Air performance measured according to ISO 5801 installation category A. For detailed information on the measurement setup, contact ebm-papst. Intake sound level: Sound power level according to ISO 13347 / sound pressure level measured at 1 m distance from fan axis. The values given are valid under the specified measuring conditions and may vary due to conditions of installation. For deviations from the standard configuration, the parameters have to be checked on the installed unit.

## Measured values

|   | U   | f  | n                 | P <sub>e</sub> | I    | q <sub>v</sub>    | p <sub>fs</sub> | q <sub>v</sub> | p <sub>fs</sub>    |
|---|-----|----|-------------------|----------------|------|-------------------|-----------------|----------------|--------------------|
|   | V   | Hz | min <sup>-1</sup> | W              | A    | m <sup>3</sup> /h | Pa              | cfm            | inH <sub>2</sub> O |
| 1 | 230 | 60 | 1250              | 55             | 0.25 | 1580              | 0               | 930            | 0.00               |
| 2 | 230 | 60 | 1225              | 56             | 0.25 | 1360              | 12              | 800            | 0.05               |
| 3 | 230 | 60 | 1195              | 57             | 0.25 | 1160              | 24              | 685            | 0.10               |
| 4 | 230 | 60 | 1155              | 58             | 0.25 | 960               | 35              | 565            | 0.14               |

U = Power supply · f = Frequency · n = Speed (rpm) · P<sub>e</sub> = Power consumption · I = Current draw · q<sub>v</sub> = Air flow · p<sub>fs</sub> = Pressure increase

