

AC axial fan

sickled blades (S series)

A4D710-AR03-03 ebmpapst Datasheet
 sales@fansco.com
 www.fansco.com

Limited partnership · Headquarters Mulfingen
 County court Stuttgart · HRA 590344

General partner Elektrobau Mulfingen GmbH · Headquarters Mulfingen
 County court Stuttgart · HRB 590142



Nominal data

| | | | |
|-------------------------------|-----------------------|------|------|
| Type | A4D710-AR03-03 | | |
| Motor | M4D138-NA | | |
| Phase | | 3~ | 3~ |
| Nominal voltage | VAC | 230 | 400 |
| Connection | | Δ | Y |
| Frequency | Hz | 50 | 50 |
| Type of data definition | | ml | ml |
| Valid for approval / standard | | CE | CE |
| Speed | min ⁻¹ | 1350 | 1350 |
| Power input | W | 2350 | 2350 |
| Current draw | A | 8.39 | 4.85 |
| Max. back pressure | Pa | 270 | 270 |
| Min. ambient temperature | °C | -40 | -40 |
| Max. ambient temperature | °C | 85 | 85 |
| Starting current | A | | 22 |

ml = max. load · me = max. efficiency · fa = running at free air · cs = customer specs · cu = customer unit
 Subject to alterations

Data according to ErP directive

| | | | | | |
|-----------------------|--------|--------------------------------|-------------------|--------------|--------------|
| Installation category | A | Overall efficiency η_{es} | Actual | Request 2013 | Request 2015 |
| Efficiency category | Static | Efficiency grade N | 39.3 | 31.9 | 35.9 |
| Variable speed drive | No | Power input P_e | 43.4 | 36 | 40 |
| Specific ratio* | 1.00 | kW | 2.22 | | |
| | | Air flow q_v | m ³ /h | 13515 | |
| | | Pressure increase p_{fs} | Pa | 234 | |
| | | Speed n | min ⁻¹ | 1360 | |

Data established at point of optimum efficiency



AC axial fan

sickled blades (S series)

Technical features

| | |
|--|--|
| Mass | 29.3 kg |
| Size | 710 mm |
| Surface of rotor | Cast in aluminium |
| Material of terminal box | PC / ABS plastic |
| Material of blades | Die-cast aluminium |
| Number of blades | 5 |
| Blade angle | -10° |
| Direction of air flow | "V" |
| Direction of rotation | Clockwise, seen on rotor |
| Type of protection | IP 54 |
| Insulation class | "F" |
| Humidity class | F3-1 |
| Max. permissible ambient motor temp. (transp./ storage) | +80 °C |
| Min. permissible ambient motor temp. (transp./storage) | -40 °C |
| Mounting position | Any |
| Condensate discharge holes | On rotor and stator sides |
| Operation mode | S1 |
| Motor bearing | Ball bearing |
| Touch current acc. IEC 60990 (measuring network Fig. 4, TN system) | <= 3.5 mA |
| Electrical leads | Via terminal box |
| Motor protection | Thermal overload protector (TOP) brought out |
| Cable exit | Axial |
| Protection class | I (if protective earth is connected by customer) |
| Product conforming to standard | EN 61800-5-1; EN 60034; CE |
| Approval | UL 1004-1; CSA C22.2 Nr.100 |



Product drawing

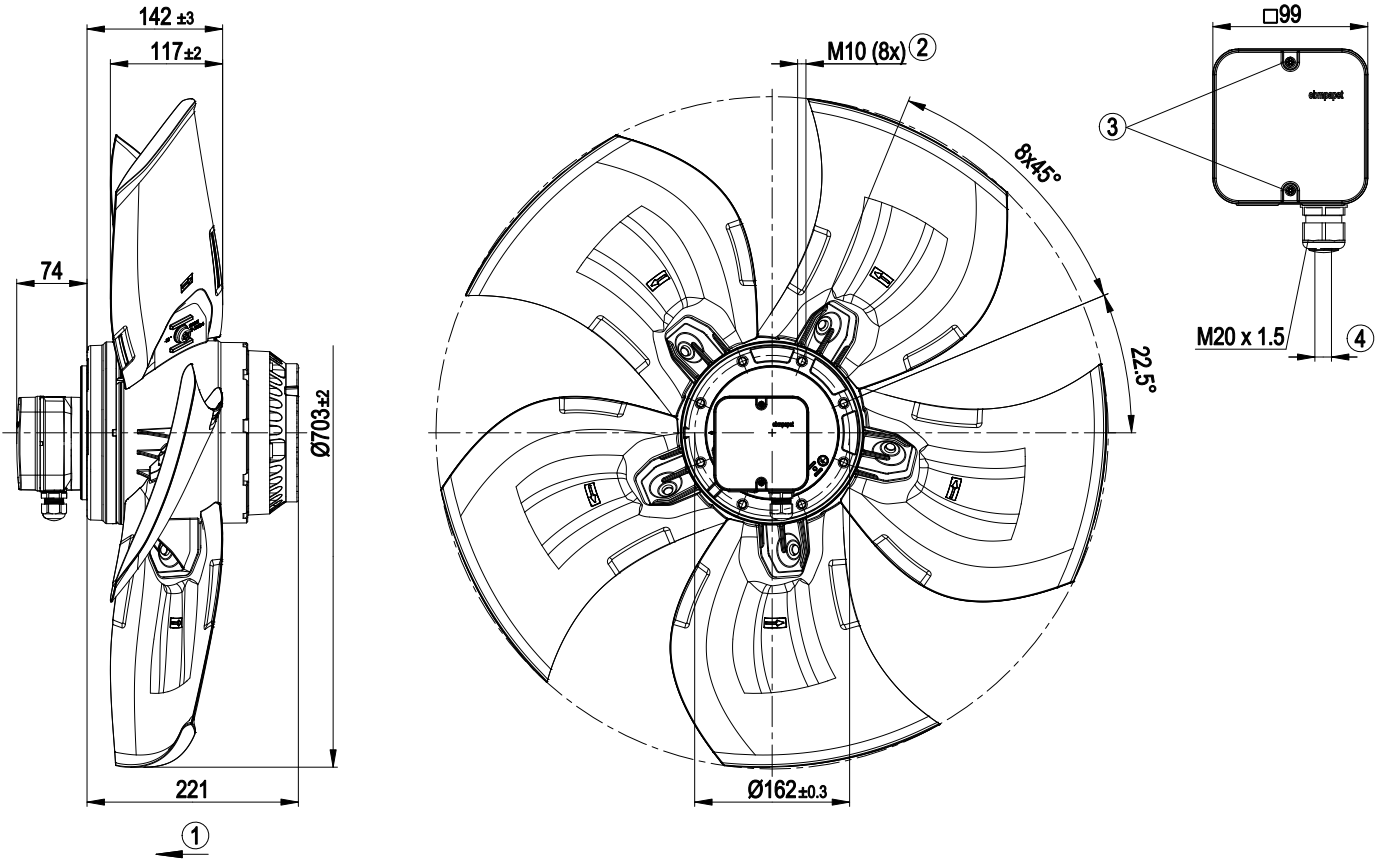

| | |
|---|--|
| 1 | Direction of air flow "V" |
| 2 | Depth of screw max. 18 mm |
| 3 | Tightening torque 1.5±0.2 Nm |
| 4 | Cable diameter: min. 7 mm, max. 14 mm; tightening torque: 2±0.3 Nm |



Connection screen

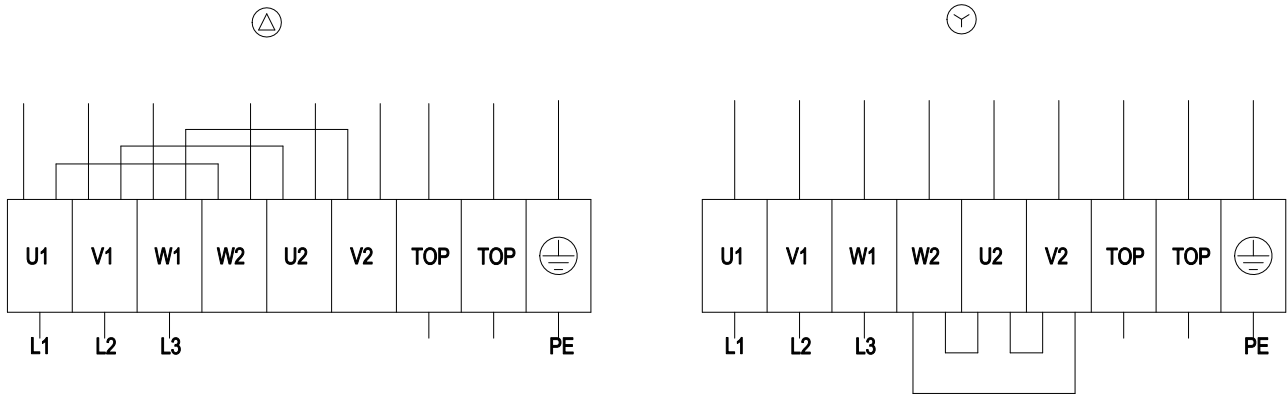

| | | | | | |
|----|------------------|----|-----------------|-----|--------------|
| Δ | Delta connection | Y | Star connection | L1 | = U1 = black |
| L2 | = V1 = blue | L3 | = W1 = brown | W2 | yellow |
| U2 | green | V2 | white | TOP | 2 x grey |
| PE | green/yellow | | | | |

Charts: Air flow 50 Hz

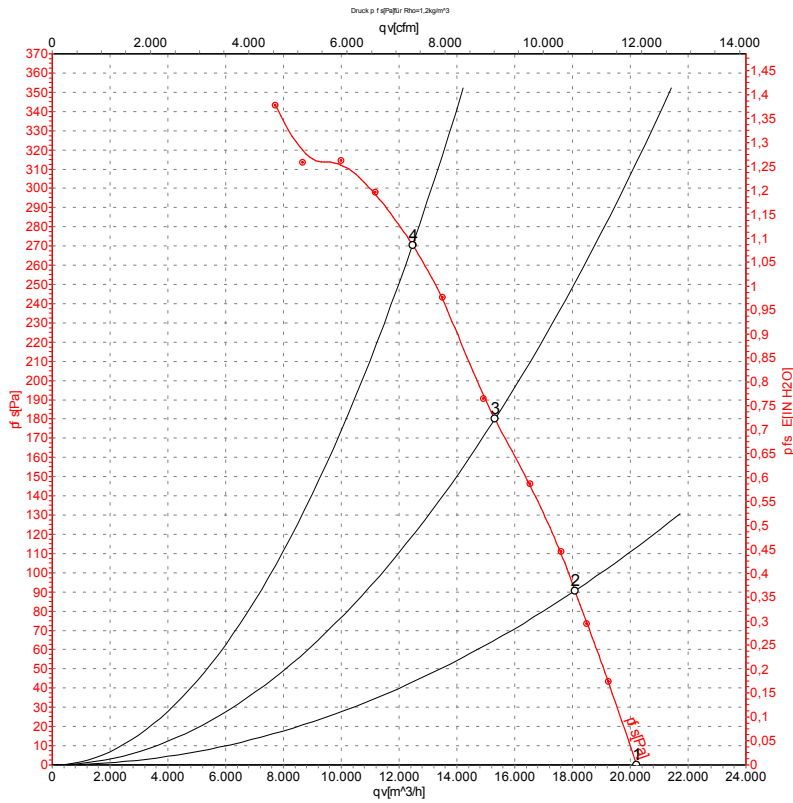

Measurement: LU-110400

Air performance measured as per ISO 5801 Installation category A. For detailed information on the measuring set-up, please contact ebmpapst. Suction-side noise levels: LwA measured as per ISO 13347 / LpA measured with 1m distance to fan axis. The values given are valid under the measuring conditions mentioned above and may vary according to the actual installation situation. With any deviation from the standard set-up, the specific values have to be checked and reviewed with the unit installed.

Measured values

| | Conn. | U | f | n | P _e | I | LpA _{in} | LwA _{in} | LwA _{out} | qv | p _{fs} |
|---|-------|-----|----|-------------------|----------------|------|-------------------|-------------------|--------------------|-------------------|-----------------|
| | | V | Hz | min ⁻¹ | W | A | dB(A) | dB(A) | dB(A) | m ³ /h | Pa |
| 1 | Y | 400 | 50 | 1420 | 1478 | 3.69 | 76 | 82 | 81 | 20220 | 0 |
| 2 | Y | 400 | 50 | 1395 | 1772 | 4.07 | 73 | 79 | 78 | 18090 | 90 |
| 3 | Y | 400 | 50 | 1370 | 2062 | 4.43 | 77 | 83 | 81 | 15320 | 180 |
| 4 | Y | 400 | 50 | 1350 | 2350 | 4.85 | 79 | 85 | 84 | 12460 | 270 |

Conn. = Connection · U = Supply voltage · f = Frequency · n = Speed · P_e = Power input · I = Current draw · LpA_{in} = Sound pressure level inlet side · LwA_{in} = Sound power level inlet side
 LwA_{out} = Sound power level outlet side · qv = Air flow · p_{fs} = Pressure increase

