

# AC axial fan

sickled blades (S series)

A4D710-AL01-01 ebmpapst Datasheet  
 sales@fansco.com  
 www.fansco.com

Limited partnership · Headquarters Muldingen  
 County court Stuttgart · HRA 590344

General partner Elektrobau Muldingen GmbH · Headquarters Muldingen  
 County court Stuttgart · HRB 590142



## Nominal data

Type	A4D710-AL01-01		
Motor	M4D138-LA		
Phase		3~	3~
Nominal voltage	VAC	400	400
Connection		$\Delta$	Y
Frequency	Hz	50	50
Type of data definition		ml	ml
Valid for approval / standard		CE	CE
Speed	min <sup>-1</sup>	1350	1090
Power input	W	2320	1590
Current draw	A	4.65	2.78
Max. back pressure	Pa	280	180
Max. ambient temperature	°C	70	70
Starting current	A	19	6.6

ml = max. load · me = max. efficiency · fa = running at free air · cs = customer specs · cu = customer unit  
 Subject to alterations

## Data according to ErP directive

		Actual	Request 2013	Request 2015
Installation category	A			
Efficiency category	Static			
Variable speed drive	No			
Specific ratio <sup>*</sup>	1.00			
Overall efficiency $\eta_{es}$		39.8	31.9	35.9
Efficiency grade N		43.9	36	40
Power input $P_e$	kW	2.25		
Air flow $q_v$	m <sup>3</sup> /h	13010		
Pressure increase $p_{fs}$	Pa	249		
Speed n	min <sup>-1</sup>	1360		

Data established at point of optimum efficiency

<sup>\*</sup> Specific ratio =  $1 + p_b / 100\,000\text{ Pa}$



# AC axial fan

sickled blades (S series)

## Technical features

Mass	26.3 kg
Size	710 mm
Surface of rotor	Cast in aluminium
Material of terminal box	PP plastic
Material of blades	Die-cast aluminium
Number of blades	5
Blade angle	-10°
Direction of air flow	"V"
Direction of rotation	Clockwise, seen on rotor
Type of protection	IP 54
Insulation class	"F"
Humidity class	F3-1
Max. permissible ambient motor temp. (transp./ storage)	+ 80 °C
Min. permissible ambient motor temp. (transp./storage)	- 40 °C
Mounting position	Any
Condensate discharge holes	On rotor and stator sides
Operation mode	S1
Motor bearing	Ball bearing
Touch current acc. IEC 60990 (measuring network Fig. 4, TN system)	<= 3.5 mA
Electrical leads	Via terminal box
Motor protection	Thermal overload protector (TOP) brought out
Cable exit	Axial
Protection class	I (if protective earth is connected by customer)
Product conforming to standard	EN 61800-5-1; EN 60034; CE
Approval	VDE



Product drawing

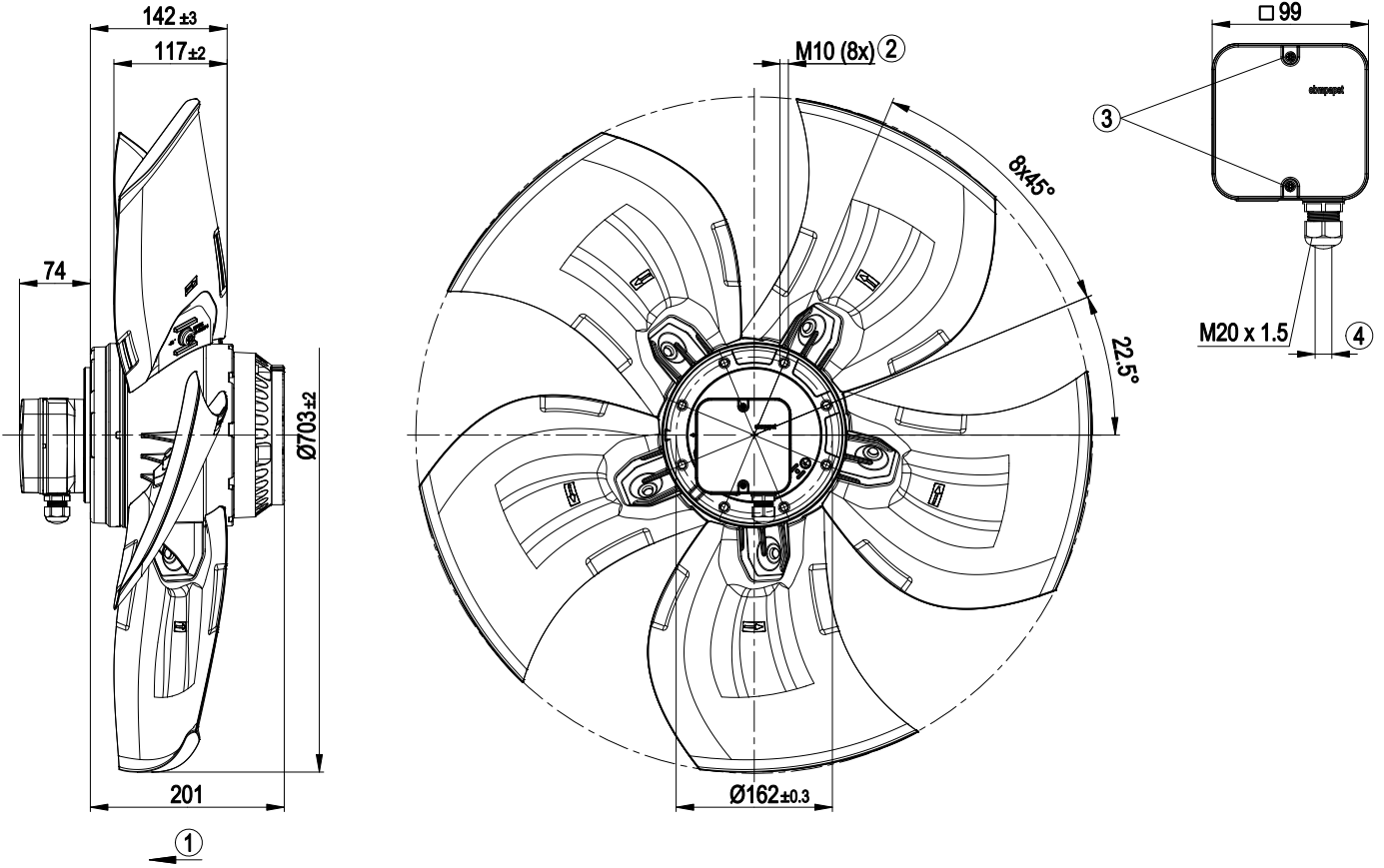

1	Direction of air flow "V"
2	Screw depth max. 18 mm
3	Tightening torque 1.5±0.2 Nm
4	Cable diameter: min. 7 mm, max. 14 mm, tightening torque: 2±0.3 Nm

## Connection screen

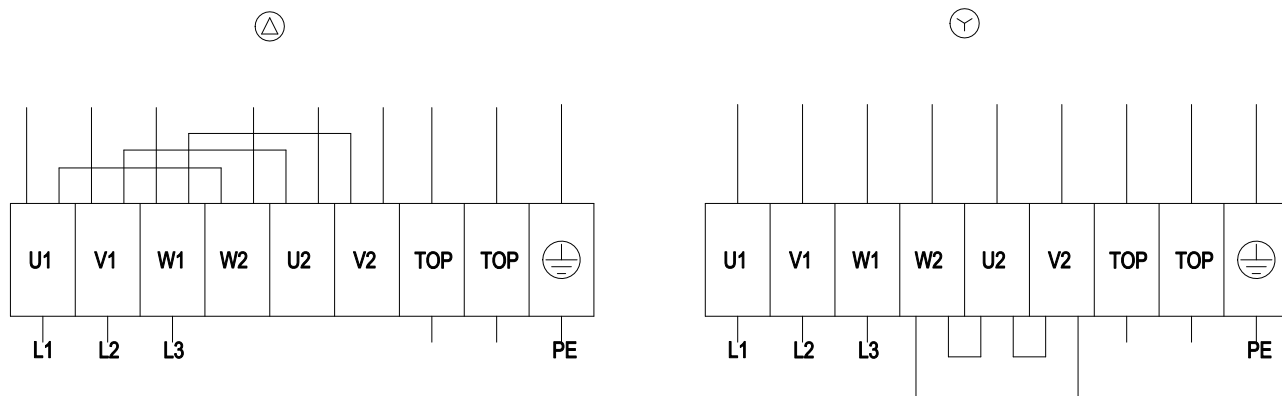

Δ	Delta connection	Y	Star connection	L1	= U1 = black
L2	= V1 = blue	L3	= W1 = brown	W2	yellow
U2	green	V2	white	TOP	2 x grey
PE	green/yellow				

## Charts: Air flow 50 Hz

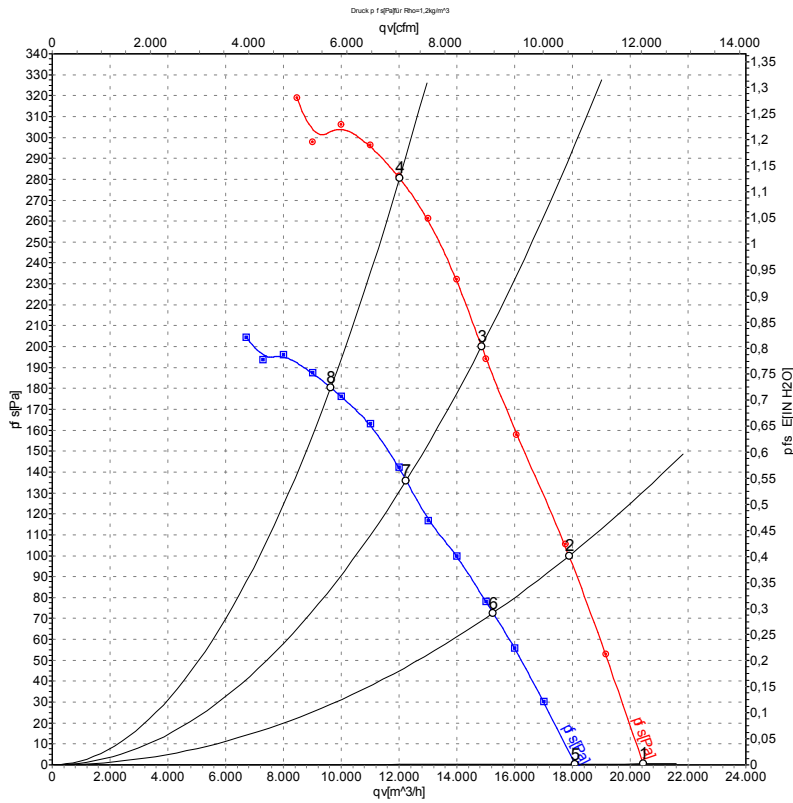

Measurement: LU-101218  
Measurement: LU-101219

Air performance measured as per ISO 5801 Installation category A. For detailed information on the measuring set-up, please contact ebmpapst. Suction-side noise levels: LwA measured as per ISO 13347 / LpA measured with 1m distance to fan axis. The values given are valid under the measuring conditions mentioned above and may vary according to the actual installation situation. With any deviation from the standard set-up, the specific values have to be checked and reviewed with the unit installed.

## Measured values

	Conn.	U	f	n	P <sub>e</sub>	I	LpA <sub>in</sub>	LwA <sub>in</sub>	qv	p <sub>fs</sub>
		V	Hz	min <sup>-1</sup>	W	A	dB(A)	dB(A)	m <sup>3</sup> /h	Pa
1	Δ	400	50	1415	1445	3.39	77	83	20460	0
2	Δ	400	50	1395	1800	3.79	74	81	17880	101
3	Δ	400	50	1370	2106	4.17	78	84	14850	200
4	Δ	400	50	1350	2320	4.65	80	87	12020	280
5	Y	400	50	1265	1142	2.00	74	81	18100	0
6	Y	400	50	1195	1347	2.35	71	77	15250	73
7	Y	400	50	1135	1501	2.61	73	79	12250	136
8	Y	400	50	1090	1590	2.78	74	81	9635	180

Conn. = Connection · U = Supply voltage · f = Frequency · n = Speed · P<sub>e</sub> = Power input · I = Current draw · LpA<sub>in</sub> = Sound pressure level inlet side · LwA<sub>in</sub> = Sound power level inlet side  
qv = Air flow · p<sub>fs</sub> = Pressure increase

