

A4D710-AF01-02 ebmpapst Datasheet

sales@fansco.com

www.fansco.com

Limited partnership · Headquarters Muldingen

Amtsgericht (court of registration) Stuttgart · HRA 590344

General partner Elektrobau Muldingen GmbH · Headquarters Muldingen

Amtsgericht (court of registration) Stuttgart · HRB 590142



## Nominal data

Type	A4D710-AF01-02		
Motor	M4D138-LA		
Phase		3~	3~
Nominal voltage	VAC	400	400
Wiring		$\Delta$	Y
Frequency	Hz	50	50
Method of obtaining data		ml	ml
Valid for approval/standard		CE	CE
Speed	min <sup>-1</sup>	1350	1095
Power consumption	W	2380	1660
Current draw	A	4.5	2.76
Max. back pressure	Pa	250	160
Min. ambient temperature	°C	-40	-40
Max. ambient temperature	°C	60	60
Starting current	A	19	6.5

ml = Max. load · me = Max. efficiency · fa = Free air · cs = Customer specification · ce = Customer equipment  
Subject to change

## Data according to ErP Directive

		Actual	Req. 2015		
01 Overall efficiency $\eta_{es}$	%	36.7	36	09 Power consumption $P_e$	kW 2.34
02 Measurement category		A		09 Air flow $q_v$	m <sup>3</sup> /h 13480
03 Efficiency category		Static		09 Pressure increase $p_{fs}$	Pa 231
04 Efficiency grade N		40.7	40	10 Speed n	min <sup>-1</sup> 1355
05 Variable speed drive		No		11 Specific ratio*	1.00

Data obtained at optimum efficiency level.

The ErP data is determined using a motor-impeller combination in a standardized measurement setup.

\* Specific ratio =  $1 + p_g / 100\,000\text{ Pa}$ 

LU-122073



## Technical description

Weight	24.1 kg
Fan size	710 mm
Rotor surface	Cast in aluminum
Terminal box material	PP plastic
Blade material	Sheet aluminum insert, sprayed with PP plastic
Number of blades	5
Blade pitch	-10°
Airflow direction	"A"
Direction of rotation	Counterclockwise, viewed toward rotor
Degree of protection	IP54
Insulation class	"F"
Moisture (F) / Environmental (H) protection class	F3-1
Max. permitted ambient temp. for motor (transport/storage)	+ 80 °C
Min. permitted ambient temp. for motor (transport/storage)	- 40 °C
Installation position	Any
Condensation drainage holes	On rotor and stator sides
Mode	S1
Motor bearing	Ball bearing
Touch current according to IEC 60990 (measuring circuit Fig. 4, TN system)	<= 3.5 mA
Electrical hookup	Via terminal box
Motor protection	Thermal overload protector (TOP) with basic insulation
With cable	Axial
Protection class	I (with customer connection of protective earth)
Conformity with standards	EN 60034; EN 61800-5-1; CE
Approval	EAC; VDE

# AC axial fan - HyBlade

sickle-shaped blades (S series), single-intake

## Product drawing

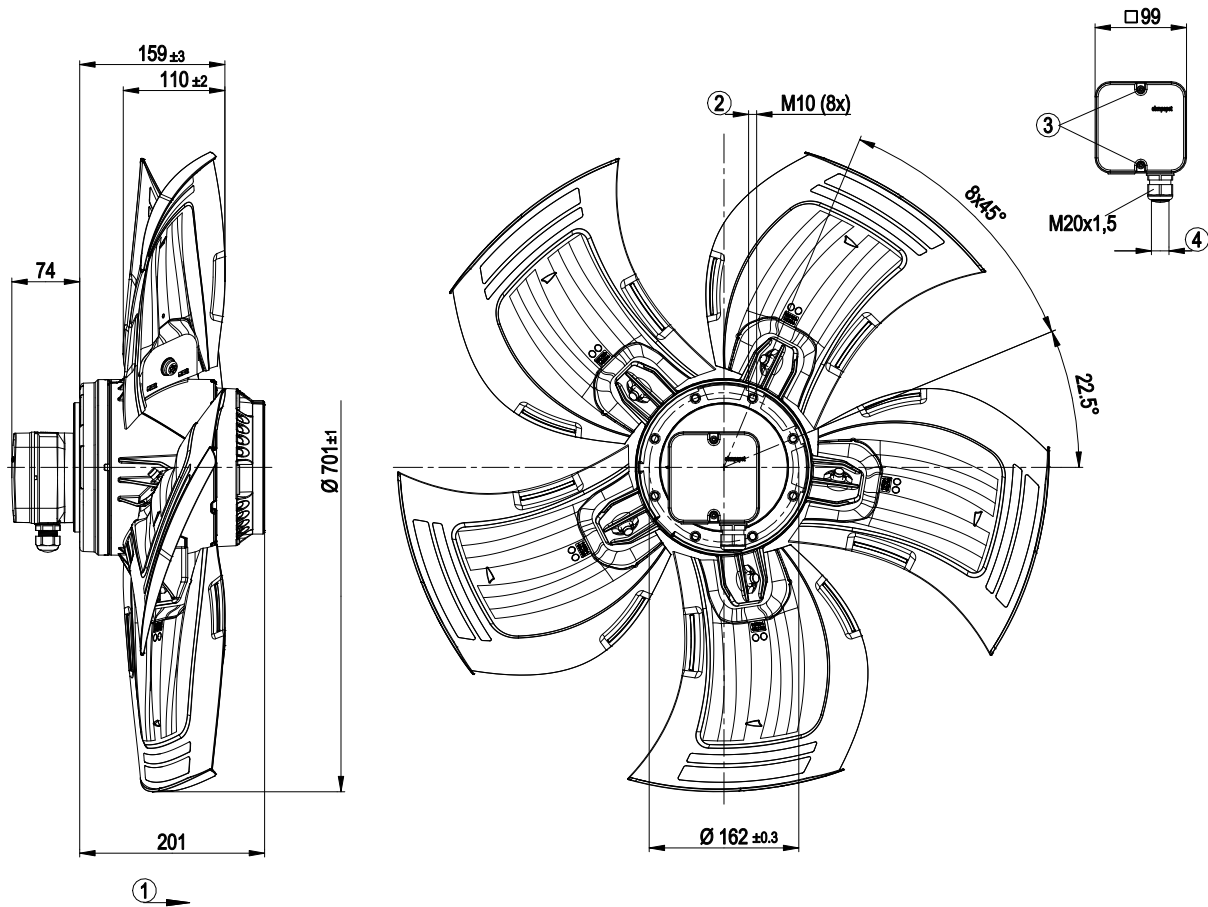

1	Direction of air flow "A"
2	Max. clearance for screw 18 mm
3	Tightening torque $1.5 \pm 0.2$ Nm
4	Cable diameter: min. 7 mm, max. 14 mm, tightening torque $2 \pm 0.3$ Nm



# AC axial fan - HyBlade

sickle-shaped blades (S series), single-intake

## Connection diagram

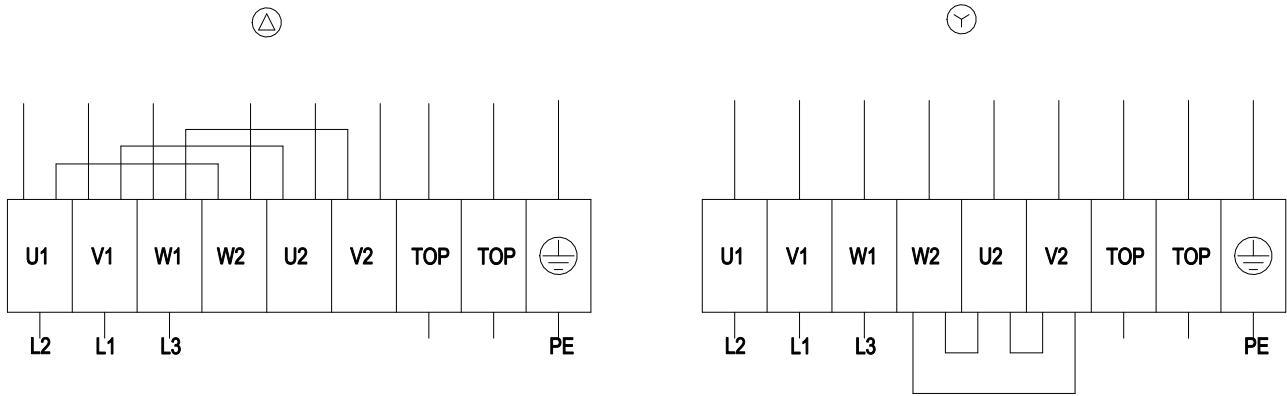

Δ	Delta connection	Y	Star connection	L1	= V1 = blue
L2	= U1 = black	L3	= W1 = brown	W2	yellow
U2	green	V2	white	TOP	2x gray
PE	green/yellow				



## Curves: Air performance 50 Hz

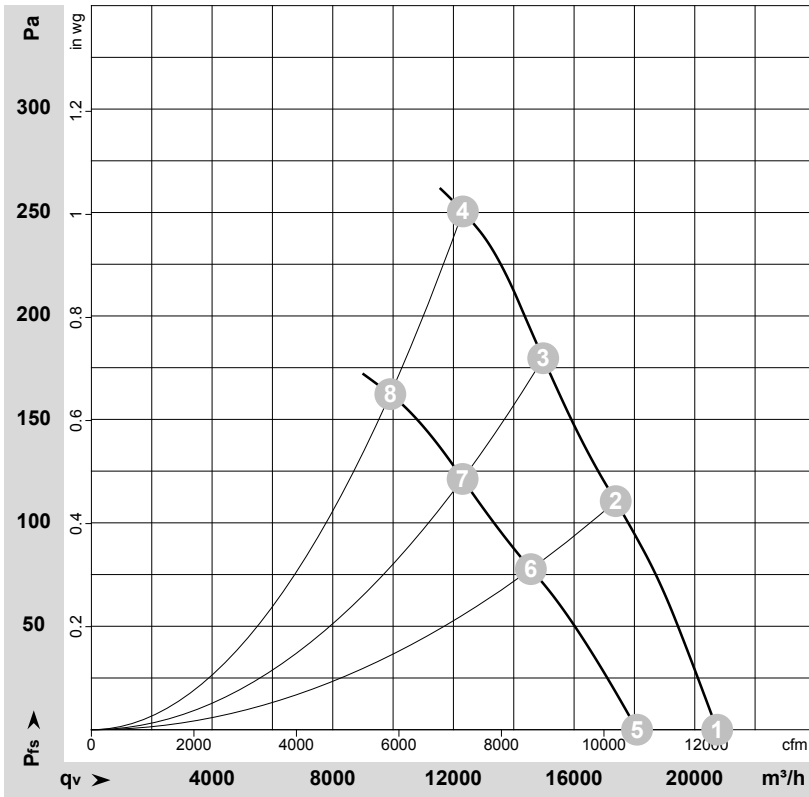

$\rho = 1.15 \text{ kg/m}^3 \pm 2 \%$

Measurement: LU-122073-1  
Measurement: LU-122081-1

Air performance measured according to ISO 5801 installation category A. For detailed information on the measurement setup, contact ebm-papst. Intake sound level: Sound power level according to ISO 13347 / sound pressure level measured at 1 m distance from fan axis. The values given are valid under the specified measuring conditions and may vary due to conditions of installation. For deviations from the standard configuration, the parameters have to be checked on the installed unit.

## Measured values

	Wired	U	f	n	P <sub>e</sub>	I	LpA <sub>in</sub>	LwA <sub>in</sub>	LwA <sub>out</sub>	qv	p <sub>fs</sub>
		V	Hz	min <sup>-1</sup>	W	A	dB(A)	dB(A)	dB(A)	m <sup>3</sup> /h	Pa
1	Δ	400	50	1415	1570	3.45	73	80	80	20745	0
2	Δ	400	50	1380	2009	3.94	75	81	81	17380	110
3	Δ	400	50	1365	2238	4.26	77	83	83	14975	180
4	Δ	400	50	1350	2380	4.50	80	87	87	12315	250
5	Y	400	50	1240	1230	2.09	70	77	77	18085	0
6	Y	400	50	1165	1481	2.52	69	76	76	14570	78
7	Y	400	50	1125	1595	2.72	71	78	77	12305	121
8	Y	400	50	1095	1660	2.76	75	82	82	9910	162

Wired = Wiring · U = Power supply · f = Frequency · n = Speed · P<sub>e</sub> = Power consumption · I = Current draw · LpA<sub>in</sub> = Sound pressure level intake side · LwA<sub>in</sub> = Sound power level intake side  
LwA<sub>out</sub> = Sound power level outlet side · qv = Air flow · p<sub>fs</sub> = Pressure increase

