



A4D710-AF01-01 ebmpapst Datasheet

sales@fansco.com

www.fansco.com

Limited partnership · Headquarters Muldingen
County court Stuttgart · HRA 590344

General partner Elektrobau Muldingen GmbH · Headquarters Muldingen
County court Stuttgart · HRB 590142

Nominal data

Type	A4D710-AF01-01		
Motor	M4D138-LA		
Phase		3~	3~
Nominal voltage	VAC	400	400
Connection		Δ	Y
Frequency	Hz	50	50
Type of data definition		ml	ml
Valid for approval / standard		CE	CE
Speed (rpm)	min ⁻¹	1350	1095
Power input	W	2380	1660
Current draw	A	4.5	2.76
Max. back pressure	Pa	250	160
Min. ambient temperature	°C	-40	-40
Max. ambient temperature	°C	60	60
Starting current	A	19	6.5

ml = Max. load · me = Max. efficiency · fa = Running at free air · cs = Customer specs · cu = Customer unit
Subject to alterations

Data according to ErP directive

		Actual	Request 2015			
01 Overall efficiency η_{es}	%	36.7	36	09 Power input P_e	kW	2.34
02 Measurement category		A		09 Air flow q_v	m ³ /h	13480
03 Efficiency category		Static		09 Pressure increase p_{fs}	Pa	231
04 Efficiency grade N		40.7	40	10 Speed (rpm) n	min ⁻¹	1355
05 Variable speed drive		No		11 Specific ratio*		1.00

Data definition with optimum efficiency.
The ErP data is determined using a motor-impeller combination in a standardised measurement configuration.

* Specific ratio = $1 + p_g / 100\,000\text{ Pa}$

LU-122073



Technical features

Mass	24.1 kg
Size	710 mm
Surface of rotor	Cast in aluminium
Material of terminal box	PP plastic
Material of blades	Aluminium sheet insert, sprayed with PP plastic
Number of blades	5
Blade angle	-10°
Direction of air flow	"V"
Direction of rotation	Clockwise, seen on rotor
Type of protection	IP 54
Insulation class	"F"
Humidity (F)/environmental protection class (H)	F3-1
Max. permissible ambient motor temp. (transp./ storage)	+ 80 °C
Min. permissible ambient motor temp. (transp./storage)	- 40 °C
Mounting position	Any
Condensate discharge holes	On rotor and stator sides
Operation mode	S1
Motor bearing	Ball bearing
Touch current acc. IEC 60990 (measuring network Fig. 4, TN system)	<= 3.5 mA
Electrical leads	Via terminal box
Motor protection	Thermal overload protector (TOP) brought out, basic insulation
Cable exit	Axial
Protection class	I (if protective earth is connected by customer)
Product conforming to standard	EN 60034; EN 61800-5-1; CE
Approval	VDE; EAC



AC axial fan - HyBlade

sickled blades (S series), single inlet

Product drawing

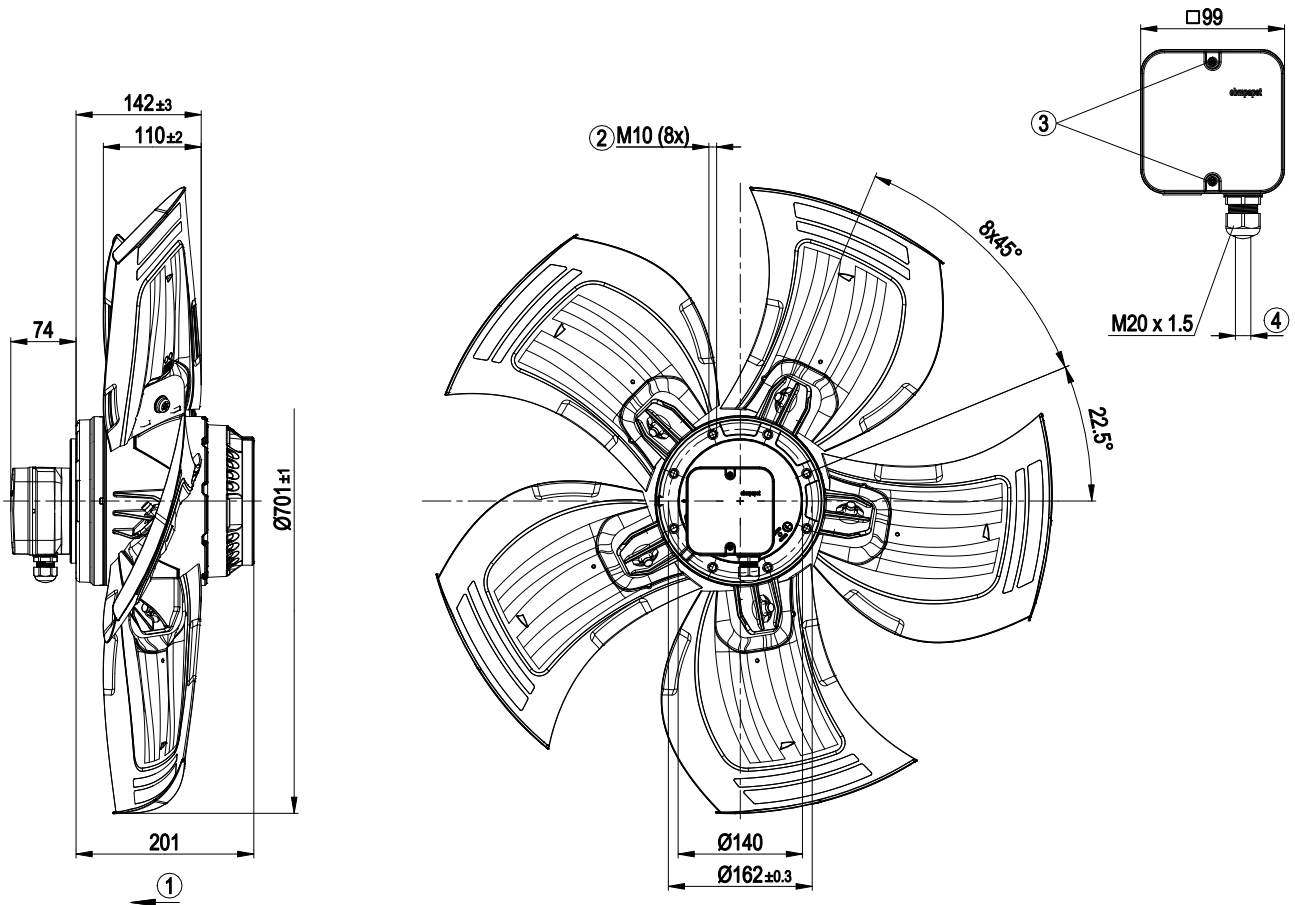

1	Direction of air flow "V"
2	Depth of screw max. 18 mm
3	Tightening torque 1.5 ± 0.2 Nm
4	Cable diameter: min. 7 mm, max. 14 mm, tightening torque: 2 ± 0.3 Nm



AC axial fan - HyBlade

sickled blades (S series), single inlet

Connection screen

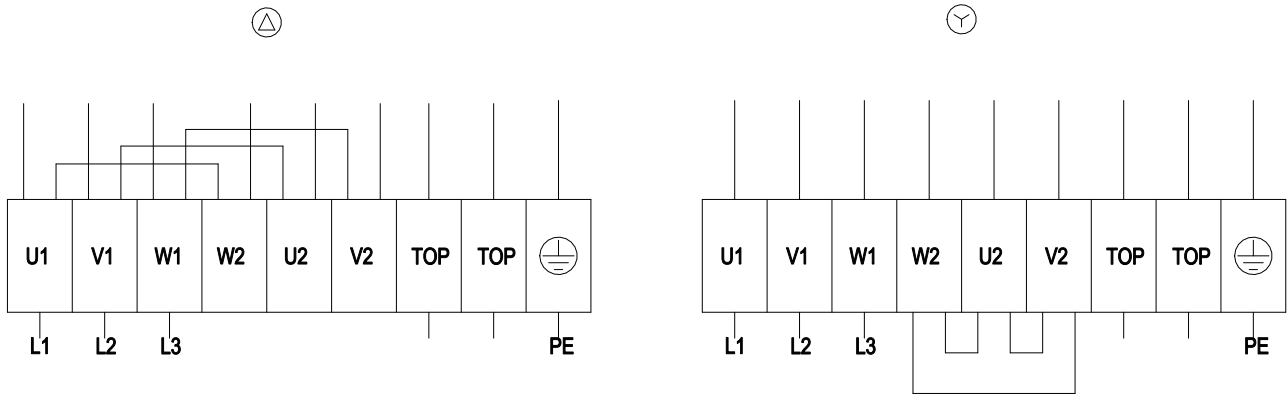

Δ	Delta connection	Y	Star connection	L1	= U1 = black
L2	= V1 = blue	L3	= W1 = brown	W2	yellow
U2	green	V2	white	TOP	2 x grey
PE	green/yellow				



Charts: Air flow 50 Hz

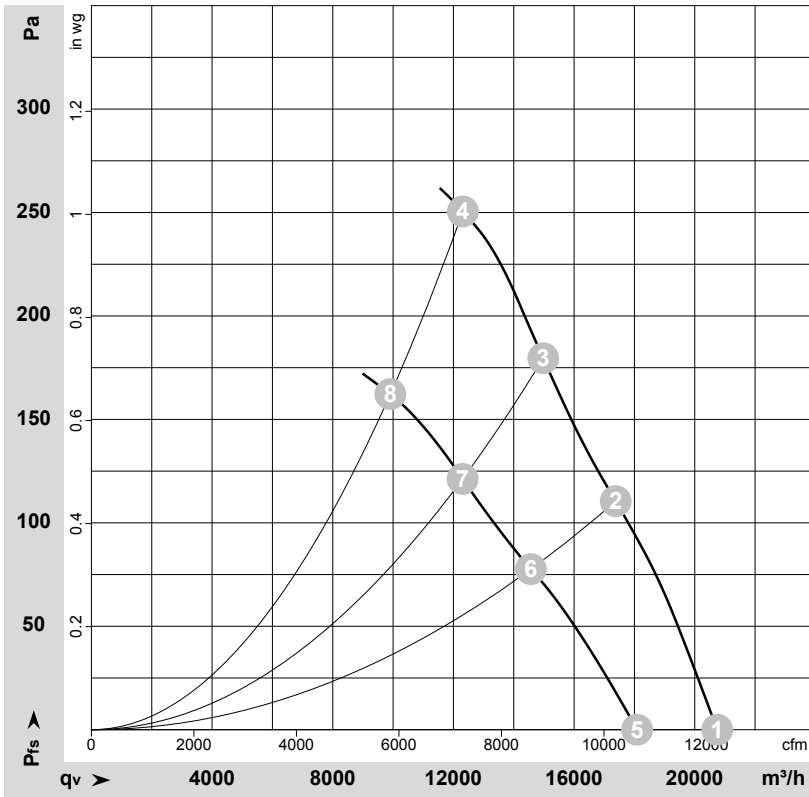

$\rho = 1.15 \text{ kg/m}^3 \pm 2 \%$

Measurement: LU-122073-1
Measurement: LU-122081-1

Air performance measured as per ISO 5801 Installation category A. For detailed information on the measuring set-up, please contact ebm-papst. Suction-side noise levels: LwA measured as per ISO 13347 / LpA measured with 1m distance to fan axis. The values given are valid under the measuring conditions mentioned above and may vary according to the actual installation situation. With any deviation from the standard set-up, the specific values have to be checked and reviewed with the unit installed.

Measured values

	Conn.	U	f	n	P _e	I	LpA _{in}	LwA _{in}	LwA _{out}	q _v	p _{fs}	q _v	p _{fs}
		V	Hz	min ⁻¹	W	A	dB(A)	dB(A)	dB(A)	m ³ /h	Pa	cfm	inH ₂ O
1	Δ	400	50	1415	1570	3.45	73	80	80	20745	0	12210	0.00
2	Δ	400	50	1380	2009	3.94	75	81	81	17380	110	10230	0.44
3	Δ	400	50	1365	2238	4.26	77	83	83	14975	180	8815	0.72
4	Δ	400	50	1350	2380	4.50	80	87	87	12315	250	7250	1.00
5	Y	400	50	1240	1230	2.09	70	77	77	18085	0	10645	0.00
6	Y	400	50	1165	1481	2.52	69	76	76	14570	78	8575	0.31
7	Y	400	50	1125	1595	2.72	71	78	77	12305	121	7240	0.49
8	Y	400	50	1095	1660	2.76	75	82	82	9910	162	5830	0.65

Conn. = Connection · U = Supply voltage · f = Frequency · n = Speed (rpm) · P_e = Power input · I = Current draw · LpA_{in} = Sound pressure level inlet side · LwA_{in} = Sound power level inlet side
LwA_{out} = Sound power level outlet side · q_v = Air flow · p_{fs} = Pressure increase

