

A4D630-AR01-01

# AC axial fan - HyBlade

sickled blades (S series)



A4D630-AR01-01 ebmpapst Datasheet

sales@fansco.com

www.fansco.com

Limited partnership · Headquarters Mulfingen  
County court Stuttgart · HRA 590344

General partner Elektrobau Mulfingen GmbH · Headquarters Mulfingen  
County court Stuttgart · HRB 590142

## Nominal data

Type	A4D630-AR01-01		
Motor	M4D110-IA		
Phase		3~	3~
Nominal voltage	VAC	400	400
Connection		Δ	Y
Frequency	Hz	50	50
Type of data definition		ml	ml
Valid for approval / standard		CE	CE
Speed (rpm)	min <sup>-1</sup>	1330	1070
Power input	W	1250	840
Current draw	A	2.48	1.42
Max. back pressure	Pa	150	100
Min. ambient temperature	°C	-40	-40
Max. ambient temperature	°C	55	55
Starting current	A	10	

ml = Max. load · me = Max. efficiency · fa = Running at free air · cs = Customer specs · cu = Customer unit  
Subject to alterations

## Data according to ErP directive

		Actual	Request 2015			
01 Overall efficiency $\eta_{es}$	%	37.9	34.5	09 Power input $P_e$	kW	1.35
02 Measurement category		A		09 Air flow $q_v$	m <sup>3</sup> /h	8830
03 Efficiency category		Static		09 Pressure increase $p_{fs}$	Pa	210
04 Efficiency grade N		43.4	40	10 Speed (rpm) n	min <sup>-1</sup>	1310
05 Variable speed drive		No		11 Specific ratio*		1.00

Data definition with optimum efficiency.  
The ErP data is determined using a motor-impeller combination in a standardised measurement configuration.

\* Specific ratio =  $1 + p_g / 100\,000\text{ Pa}$

LU-107579



### Technical features

Mass	12.2 kg
Size	630 mm
Surface of rotor	Cast in aluminium
Material of terminal box	PP plastic
Material of blades	Aluminium sheet insert, sprayed with PP plastic
Number of blades	5
Blade angle	-10°
Direction of air flow	"V"
Direction of rotation	Counter-clockwise, seen on rotor
Type of protection	IP 54
Insulation class	"F"
Humidity (F)/environmental protection class (H)	F3-1
Max. permissible ambient motor temp. (transp./ storage)	+ 80 °C
Min. permissible ambient motor temp. (transp./storage)	- 40 °C
Mounting position	Shaft horizontal or rotor on bottom; rotor on top on request
Condensate discharge holes	Rotor-side
Operation mode	S1
Motor bearing	Ball bearing
Touch current acc. IEC 60990 (measuring network Fig. 4, TN system)	<= 3.5 mA
Electrical leads	Via terminal box
Motor protection	Thermal overload protector (TOP) brought out, basic insulation
Cable exit	Axial
Protection class	I (if protective earth is connected by customer)
Product conforming to standard	EN 61800-5-1; CE
Approval	VDE; EAC; CCC



# AC axial fan - HyBlade

sickled blades (S series)

## Product drawing

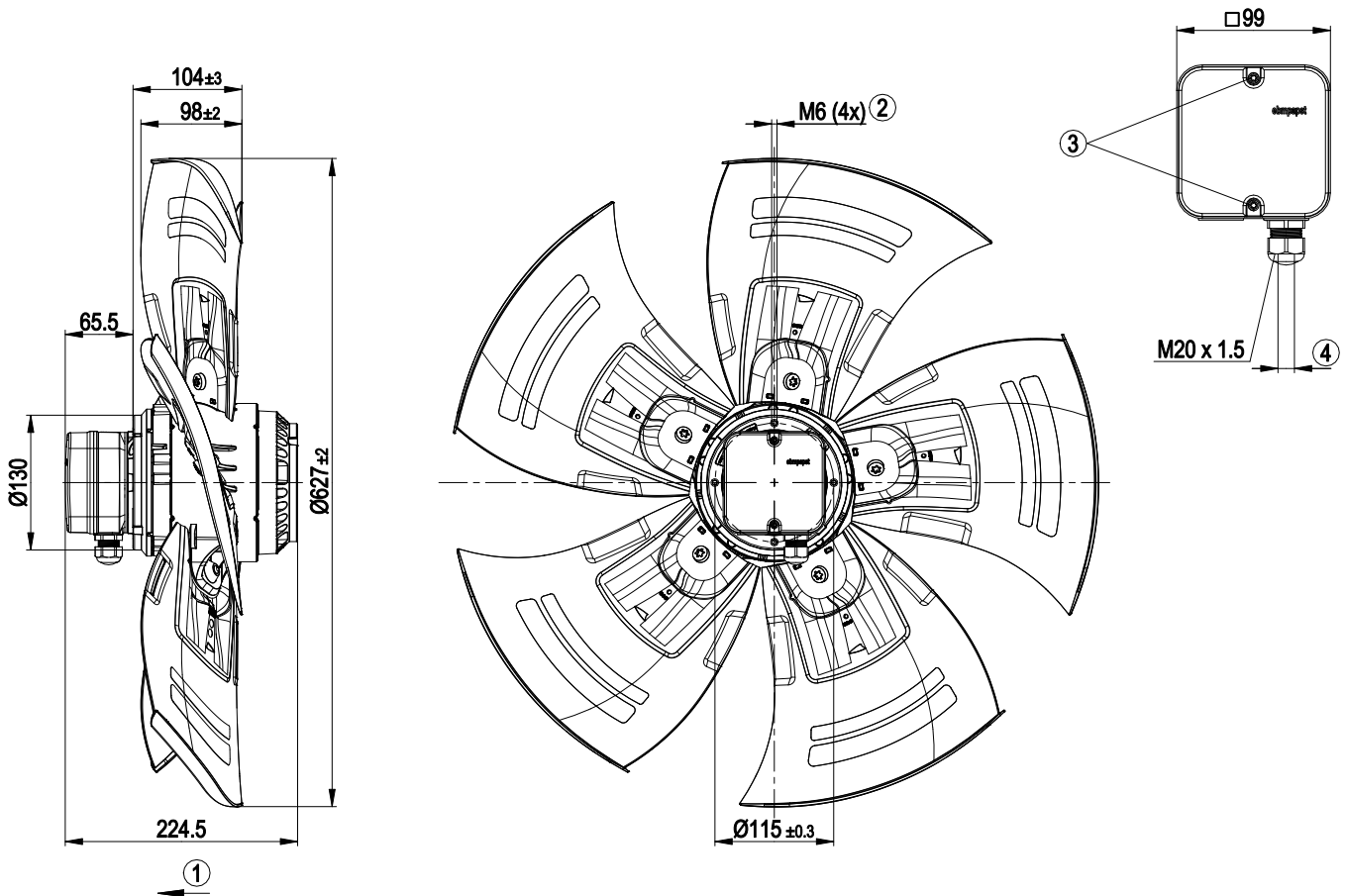

1	Direction of air flow "V"
2	Screw depth max. 12 mm
3	Tightening torque 1.5±0.2 Nm
4	Cable diameter: min. 6 mm, max. 12 mm; tightening torque: 2±0.3 Nm



## Connection screen



Δ	Delta connection	Y	Star connection	L1	= V1 = blue
L2	= U1 = black	L3	= W1 = brown	W2	yellow
U2	green	V2	white	TOP	2 x grey
PE	green/yellow				

## Charts: Air flow 50 Hz

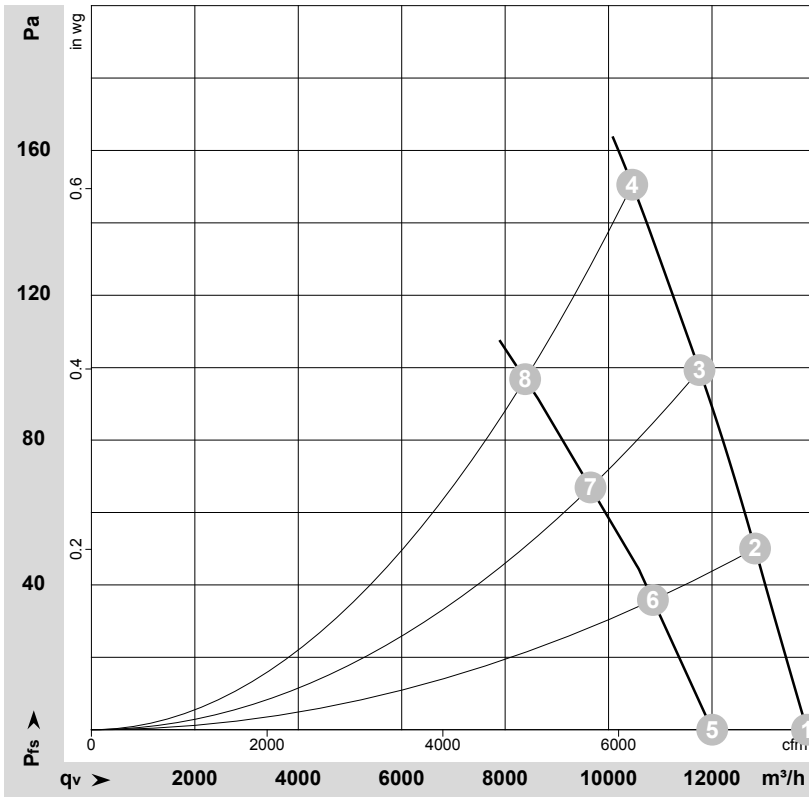

$\rho = 1.177 \text{ kg/m}^3 \pm 2 \%$

Measurement: LU-107579-1  
Measurement: LU-107929-1

Air performance measured as per ISO 5801 Installation category A. For detailed information on the measuring set-up, please contact ebm-papst. Suction-side noise levels: LwA measured as per ISO 13347 / LpA measured with 1m distance to fan axis. The values given are valid under the measuring conditions mentioned above and may vary according to the actual installation situation. With any deviation from the standard set-up, the specific values have to be checked and reviewed with the unit installed.

## Measured values

	Conn.	U	f	n	P <sub>e</sub>	I	LpA <sub>in</sub>	LwA <sub>in</sub>	LwA <sub>out</sub>	q <sub>v</sub>	p <sub>fs</sub>	q <sub>v</sub>	p <sub>fs</sub>
		V	Hz	min <sup>-1</sup>	W	A	dB(A)	dB(A)	dB(A)	m <sup>3</sup> /h	Pa	cfm	inH2O
1	Δ	400	50	1395	882	2.06	73	79	79	13835	0	8145	0.00
2	Δ	400	50	1375	1006	2.18	70	77	77	12835	50	7555	0.20
3	Δ	400	50	1355	1127	2.31	68	75	75	11760	100	6920	0.40
4	Δ	400	50	1330	1250	2.48	69	75	75	10460	150	6155	0.60
5	Y	400	50	1205	659	1.12	69	76	75	12005	0	7065	0.00
6	Y	400	50	1150	722	1.21	66	73	72	10860	36	6390	0.14
7	Y	400	50	1105	776	1.30	64	71	70	9650	67	5680	0.27
8	Y	400	50	1070	840	1.42	63	70	69	8385	97	4935	0.39

Conn. = Connection · U = Supply voltage · f = Frequency · n = Speed (rpm) · P<sub>e</sub> = Power input · I = Current draw · LpA<sub>in</sub> = Sound pressure level inlet side · LwA<sub>in</sub> = Sound power level inlet side  
LwA<sub>out</sub> = Sound power level outlet side · q<sub>v</sub> = Air flow · p<sub>fs</sub> = Pressure increase

