

A4D560-AO03-02 ebmpapst Datasheet

sales@fansco.com

www.fansco.com

Limited partnership · Headquarters Muldingen

Amtsgericht (court of registration) Stuttgart · HRA 590344

General partner Elektrobau Muldingen GmbH · Headquarters Muldingen

Amtsgericht (court of registration) Stuttgart · HRB 590142



Nominal data

Type	A4D560-AO03-02				
Motor	M4D110-GF				
Phase		3~	3~	3~	3~
Nominal voltage	VAC	400	400	480	480
Wiring		Δ	Y	Δ	Y
Frequency	Hz	50	50	60	60
Method of obtaining data		ml	ml	ml	ml
Valid for approval/standard		CE	CE	CE	CE
Speed (rpm)	min ⁻¹	1320	1050	1540	1160
Power consumption	W	810	540	1300	810
Current draw	A	1.54	0.92	1.94	1.16
Max. back pressure	Pa	160	100	220	125
Max. back pressure	inH ₂ O	0.64	0.4	0.88	0.5
Min. ambient temperature	°C	-40	-40	-40	-40
Max. ambient temperature	°C	65	65	45	45
Starting current	A	6.5	6.5	7.5	7.5

ml = Max. load · me = Max. efficiency · fa = Free air · cs = Customer specification · ce = Customer equipment
Subject to change

Data according to ErP Directive

		Actual	Req. 2015			
01 Overall efficiency η_{es}	%	34.9	33.1	09 Power consumption P_e	kW	0.8
02 Measurement category		A		09 Air flow q_v	m ³ /h	6370
03 Efficiency category		Static		09 Pressure increase p_{fs}	Pa	160
04 Efficiency grade N		41.8	40	10 Speed (rpm) n	min ⁻¹	1325
05 Variable speed drive		No		11 Specific ratio*		1.00

Data obtained at optimum efficiency level.
The ErP data is determined using a motor-impeller combination in a standardized measurement setup.

* Specific ratio = $1 + p_{fs} / 100\,000\text{ Pa}$

LU-111257



Technical description

Weight	10.7 kg
Fan size	560 mm
Rotor surface	Cast in aluminum
Terminal box material	PP plastic
Blade material	Sheet aluminum insert, sprayed with PP plastic
Number of blades	5
Blade pitch	-10°
Airflow direction	"A"
Direction of rotation	Clockwise, viewed toward rotor
Degree of protection	IP54
Insulation class	"F"
Moisture (F) / Environmental (H) protection class	F3-1
Max. permitted ambient temp. for motor (transport/storage)	+80 °C
Min. permitted ambient temp. for motor (transport/storage)	-40 °C
Installation position	Shaft horizontal or rotor on bottom; rotor on top on request
Condensation drainage holes	On rotor side
Mode	S1
Motor bearing	Ball bearing
Touch current according to IEC 60990 (measuring circuit Fig. 4, TN system)	<= 3.5 mA
Electrical hookup	Via terminal box
Motor protection	Thermal overload protector (TOP) with basic insulation
With cable	Axial
Protection class	I (with customer connection of protective earth)
Conformity with standards	EN 61800-5-1; CE
Approval	VDE; EAC

AC axial fan - HyBlade

sickle-shaped blades (S series)

Product drawing

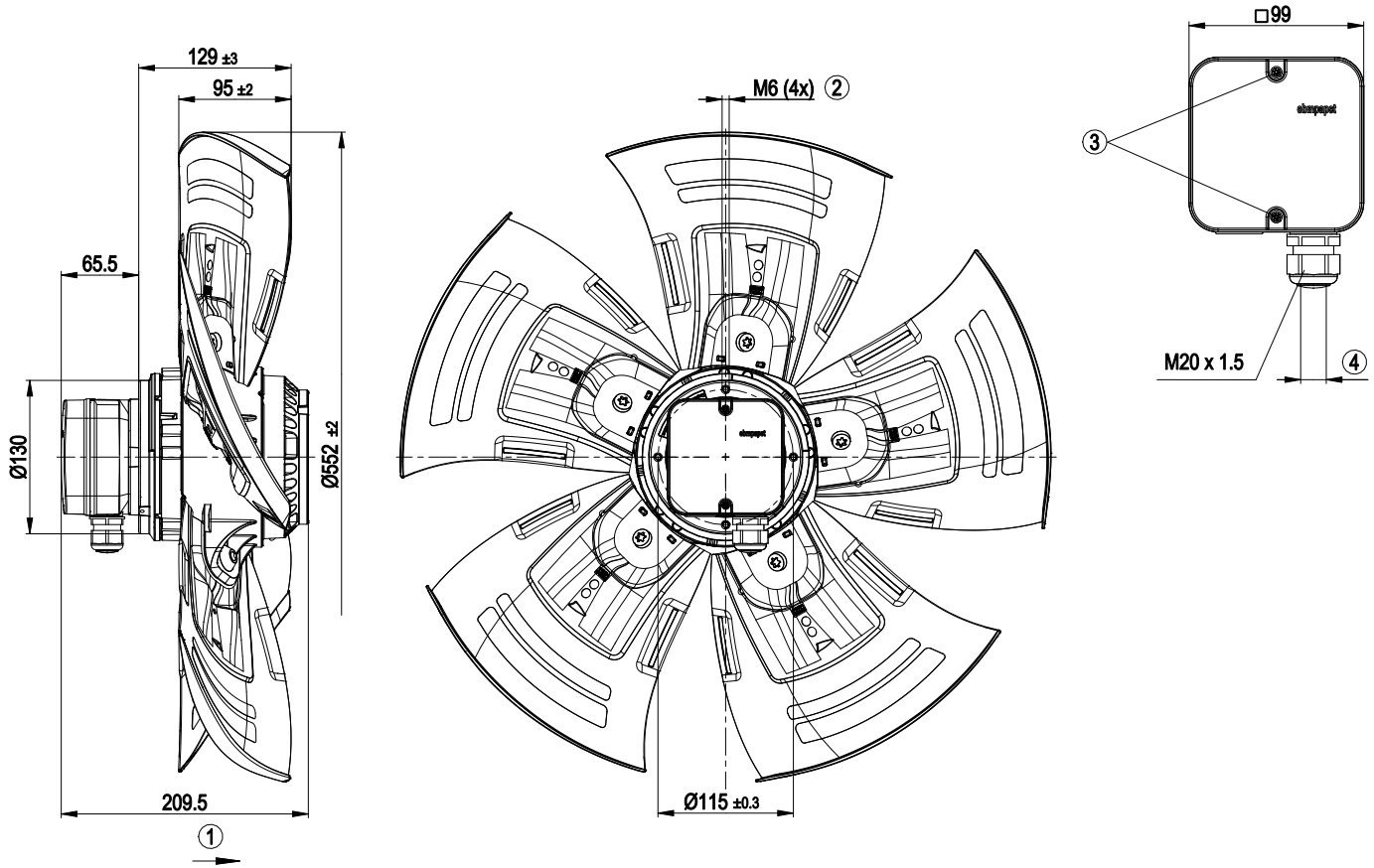

1	Direction of air flow "A"
2	Max. clearance for screw 12 mm
3	Tightening torque 1.5 ± 0.2 Nm
4	Cable diameter min. 6 mm, max. 12 mm; tightening torque 2 ± 0.3 Nm



Connection diagram



Δ	Delta connection	Y	Star connection	L1	= U1 = black
L2	= V1 = blue	L3	= W1 = brown	W2	yellow
U2	green	V2	white	TOP	2x gray
PE	green/yellow				

Curves: Air performance 50 Hz

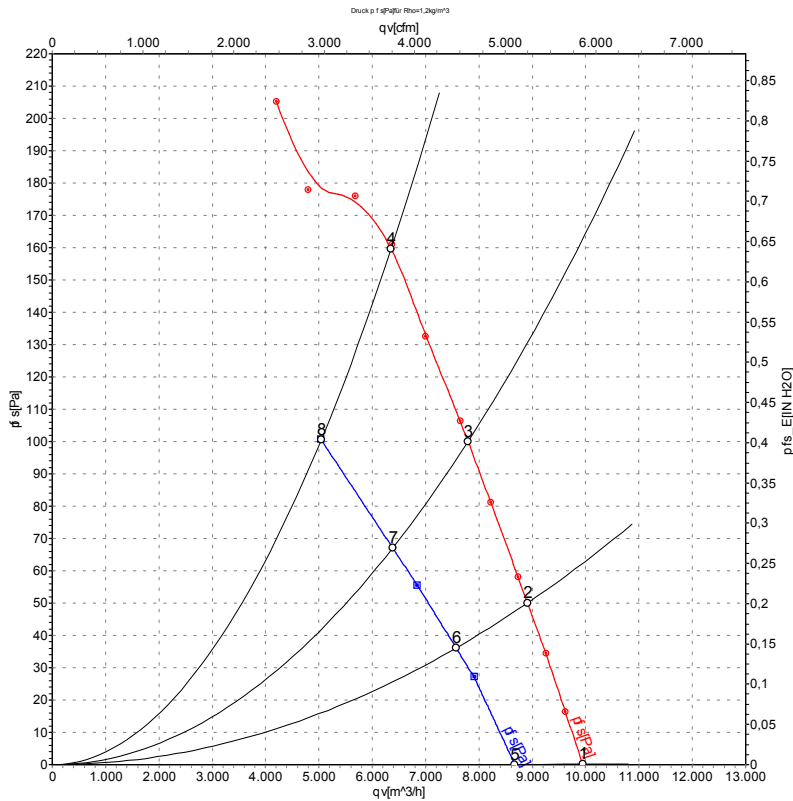

Measurement: LU-111257-1
Measurement: LU-113260-1

Air performance measured according to ISO 5801 installation category A. For detailed information on the measurement setup, contact ebm-papst. Intake sound level: Sound power level according to ISO 13347 / sound pressure level measured at 1 m distance from fan axis. The values given are valid under the specified measuring conditions and may vary due to conditions of installation. For deviations from the standard configuration, the parameters have to be checked on the installed unit.

Measured values

	Wired	U	f	n	P _e	I	LpA _{in}	LwA _{in}	LwA _{out}	qv	p _{fs}	qv	p _{fs}
		V	Hz	min ⁻¹	W	A	dB(A)	dB(A)	dB(A)	m ³ /h	Pa	CFM	inH2O
1	Δ	400	50	1385	558	1.23	71	77	76	9945	0	5855	0.00
2	Δ	400	50	1365	644	1.32	67	73	73	8910	50	5245	0.20
3	Δ	400	50	1345	732	1.42	68	74	73	7795	100	4590	0.40
4	Δ	400	50	1320	810	1.54	69	75	75	6355	160	3740	0.64
5	Y	400	50	1200	418	0.70	67	73	72	8570	0	5045	0.00
6	Y	400	50	1145	467	0.78	63	70	69	7570	36	4455	0.14
7	Y	400	50	1095	507	0.85	63	70	69	6385	67	3755	0.27
8	Y	400	50	1050	540	0.92	64	70	70	5040	100	2970	0.40

Wired = Wiring · U = Power supply · f = Frequency · n = Speed (rpm) · P_e = Power consumption · I = Current draw · LpA_{in} = Sound pressure level intake side · LwA_{in} = Sound power level intake side
LwA_{out} = Sound power level outlet side · qv = Air flow · p_{fs} = Pressure increase



Curves: Air performance 60 Hz

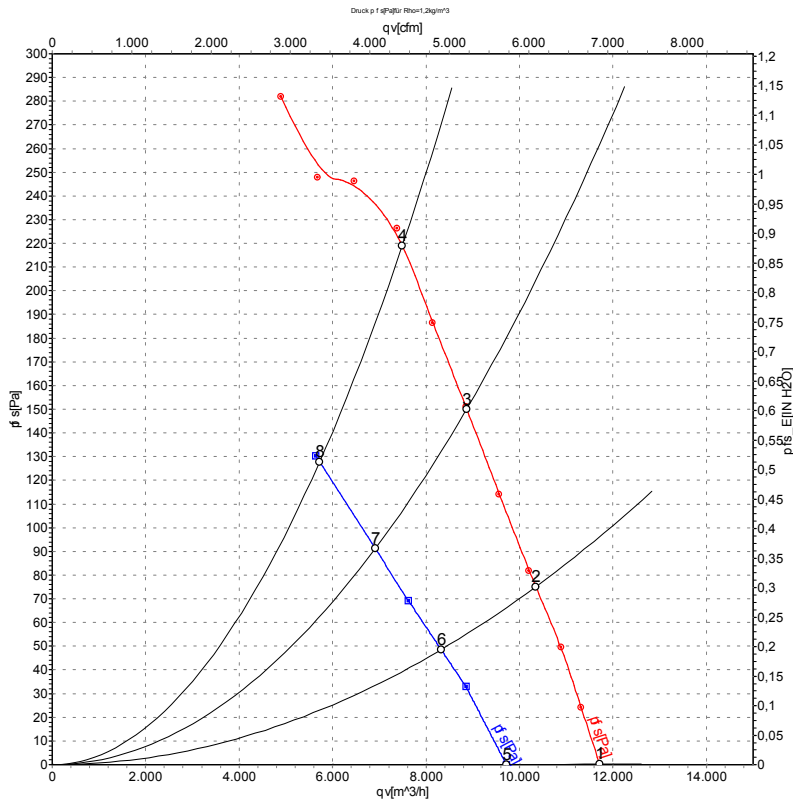

Measurement: LU-111253-1
Measurement: LU-113262-1

Air performance measured according to ISO 5801 installation category A. For detailed information on the measurement setup, contact ebm-papst. Intake sound level: Sound power level according to ISO 13347 / sound pressure level measured at 1 m distance from fan axis. The values given are valid under the specified measuring conditions and may vary due to conditions of installation. For deviations from the standard configuration, the parameters have to be checked on the installed unit.

Measured values

	Wired	U	f	n	P _e	I	LpA _{in}	LwA _{in}	LwA _{out}	qv	p _{fs}	qv	p _{fs}
		V	Hz	min ⁻¹	W	A	dB(A)	dB(A)	dB(A)	m ³ /h	Pa	CFM	inH2O
1	Δ	480	60	1640	888	1.44	75	81	81	11720	0	6900	0.00
2	Δ	480	60	1605	1050	1.60	71	77	77	10350	75	6090	0.30
3	Δ	480	60	1570	1196	1.77	72	78	77	8870	150	5220	0.60
4	Δ	480	60	1540	1300	1.94	73	79	79	7490	220	4410	0.88
5	Y	480	60	1360	652	0.91	70	76	76	9715	0	5720	0.00
6	Y	480	60	1270	713	1.00	65	72	71	8325	48	4900	0.19
7	Y	480	60	1205	768	1.09	65	71	71	6910	91	4070	0.37
8	Y	480	60	1160	810	1.16	67	73	72	5725	125	3370	0.50

Wired = Wiring · U = Power supply · f = Frequency · n = Speed (rpm) · P_e = Power consumption · I = Current draw · LpA_{in} = Sound pressure level intake side · LwA_{in} = Sound power level intake side
LwA_{out} = Sound power level outlet side · qv = Air flow · p_{fs} = Pressure increase

