

A4D500-AM03-35 ebmpapst Datasheet

sales@fansco.com

www.fansco.com

Limited partnership · Headquarters Mulfingen

Amtsgericht (court of registration) Stuttgart · HRA 590344

General partner Elektrobau Mulfingen GmbH · Headquarters Mulfingen

Amtsgericht (court of registration) Stuttgart · HRB 590142

Nominal data

Type	A4D500-AM03-35			
Motor	M4D110-GF			
Phase		3~	3~	3~
Nominal voltage	VAC	400	400	460
Wiring		Δ	Y	Δ
Frequency	Hz	50	50	60
Method of obtaining data		ml	ml	ml
Valid for approval/standard		CE	CE	CE
Speed (rpm)	min ⁻¹	1390	1180	1640
Power consumption	W	720	550	1060
Current draw	A	1.41	0.9	1.64
Max. back pressure	Pa	140	100	138
Max. back pressure	in. wg	0.56	0.4	0.55
Min. ambient temperature	°C	-25	-25	-25
Max. ambient temperature	°C	65	65	60
Starting current	A	6.5	2.2	6.8

ml = Max. load · me = Max. efficiency · fa = Free air · cs = Customer specification · ce = Customer equipment
Subject to change

Data according to Commission Regulation (EU) 327/2011

		Actual	Req. 2015			
01 Overall efficiency η_{es}	%	33.4	32.8	09 Power consumption P_e	kW	0.73
02 Measurement category		A		09 Air flow q_v	m ³ /h	5860
03 Efficiency category		Static		09 Pressure increase p_{fs}	Pa	151
04 Efficiency grade N		40.6	40	10 Speed (rpm) n	min ⁻¹	1385
05 Variable speed drive		No		11 Specific ratio*		1.00

Data obtained at optimum efficiency level.
The ErP data is determined using a motor-impeller combination in a standardized measurement setup.

* Specific ratio = $1 + p_{fs} / 100\,000\text{ Pa}$

LU-106631



AC axial fan - HyBlade

sickle-shaped blades (S series)

for barn ventilation

Technical description

Weight	9.5 kg
Size	500 mm
Motor size	110
Rotor surface	Painted black
Terminal box material	PP plastic
Blade material	Press-fitted, painted sheet steel blank, sprayed with PP plastic
Number of blades	5
Airflow direction	A
Direction of rotation	Clockwise, viewed toward rotor
Degree of protection	IP54
Insulation class	"F"
Moisture (F) / Environmental (H) protection class	H2+
Ambient temperature note	Occasional start-up at temperatures between -40°C and -25°C is permitted. For continuous operation at ambient temperatures below -25°C (such as refrigeration applications), use must be made of a fan design with special low-temperature bearings.
Max. permitted ambient temp. for motor (transport/storage)	+80 °C
Min. permitted ambient temp. for motor (transport/storage)	-40 °C
Installation position	Shaft horizontal or rotor on top; rotor on bottom on request
Condensation drainage holes	On stator side
Mode	S1
Motor bearing	Ball bearing
Touch current according to IEC 60990 (measuring circuit Fig. 4, TN system)	<= 3.5 mA
Electrical hookup	Terminal box
Motor protection	Thermal overload protector (TOP) with basic insulation
With cable	Axial
Protection class	I (with customer connection of protective earth)
Conformity with standards	EN 60034-1 (2010); CE
Approval	EAC; VDE



AC axial fan - HyBlade

sickle-shaped blades (S series)

for barn ventilation

Product drawing

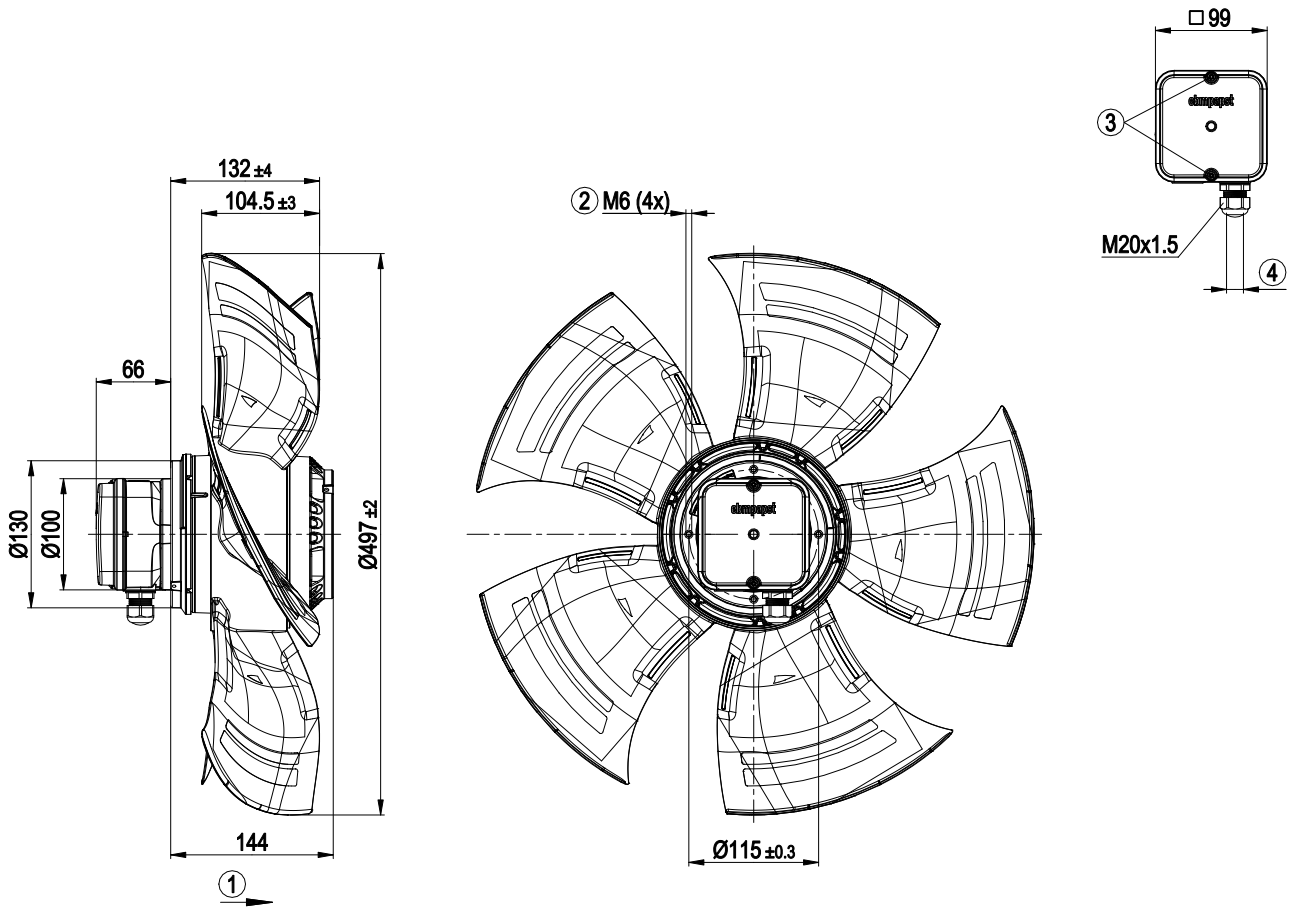

1	Direction of air flow "A"
2	Max. clearance for screw 12 mm
3	Tightening torque 1.5 ± 0.2 Nm
4	Cable diameter min. 6 mm, max. 12 mm, tightening torque 2 ± 0.3 Nm



AC axial fan - HyBlade

sickle-shaped blades (S series)

for barn ventilation

Connection diagram

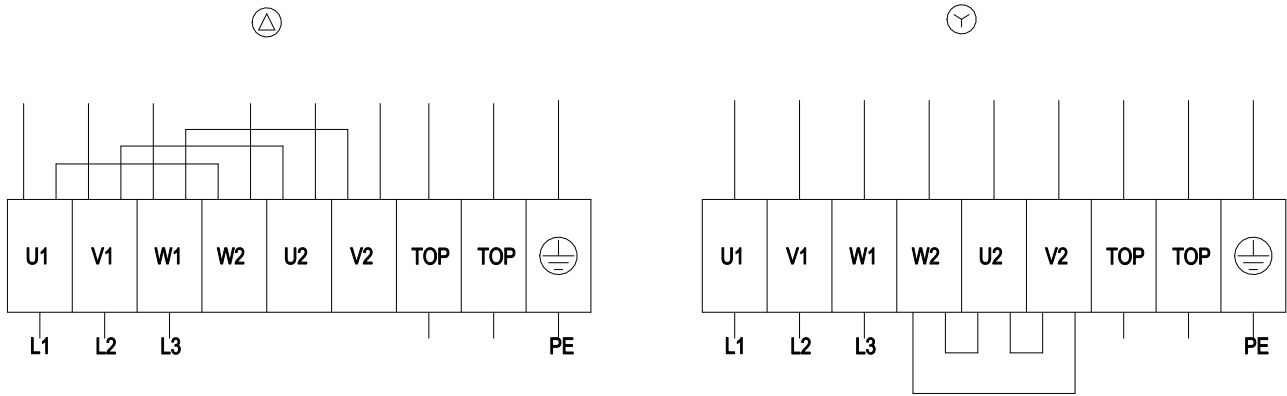

Δ	Delta connection	Y	Star connection	L1	= U1 = black
L2	= V1 = blue	L3	= W1 = brown	W2	yellow
U2	green	V2	white	TOP	2x gray
PE	green/yellow				



AC axial fan - HyBlade

sickle-shaped blades (S series)

for barn ventilation

Curves: Air performance 50 Hz

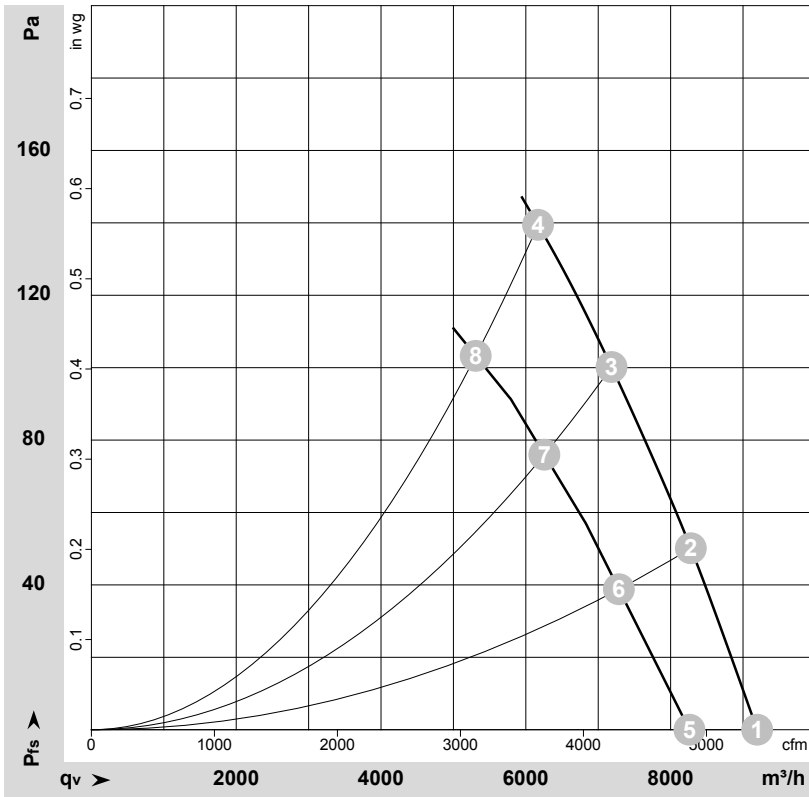

$\rho = 1.15 \text{ kg/m}^3 \pm 2 \%$

Measurement: LU-106631-1
Measurement: LU-106885-1

Air performance measured according to ISO 5801 installation category A. For detailed information on the measurement setup, contact ebm-papst. Intake sound level: Sound power level according to ISO 13347 / sound pressure level measured at 1 m distance from fan axis. The values given are valid under the specified measuring conditions and may vary due to conditions of installation. For deviations from the standard configuration, the parameters have to be checked on the installed unit.

Measured values

	Wired	U	f	n	P _e	I	LpA _{in}	LwA _{in}	LwA _{out}	q _v	p _{fs}	q _v	p _{fs}
		V	Hz	min ⁻¹	W	A	dB(A)	dB(A)	dB(A)	m ³ /h	Pa	cfm	in. wg
1	Δ	400	50	1420	540	1.20	68	75	75	9195	0	5410	0.00
2	Δ	400	50	1410	605	1.28	65	72	72	8280	50	4875	0.20
3	Δ	400	50	1400	663	1.35	64	71	71	7185	100	4230	0.40
4	Δ	400	50	1390	720	1.41	64	72	72	6170	140	3630	0.56
5	Y	400	50	1275	433	0.71		72	73	8260	0	4860	0.00
6	Y	400	50	1240	478	0.78		70	70	7285	39	4290	0.16
7	Y	400	50	1215	518	0.85		68	68	6255	76	3680	0.31
8	Y	400	50	1180	550	0.90		68	68	5310	103	3125	0.41

Wired = Wiring · U = Voltage · f = Frequency · n = Speed (rpm) · P_e = Power consumption · I = Current draw · LpA_{in} = Sound pressure level intake side · LwA_{in} = Sound power level intake side
LwA_{out} = Sound power level outlet side · q_v = Air flow · p_{fs} = Pressure increase



Curves: Air performance 60 Hz

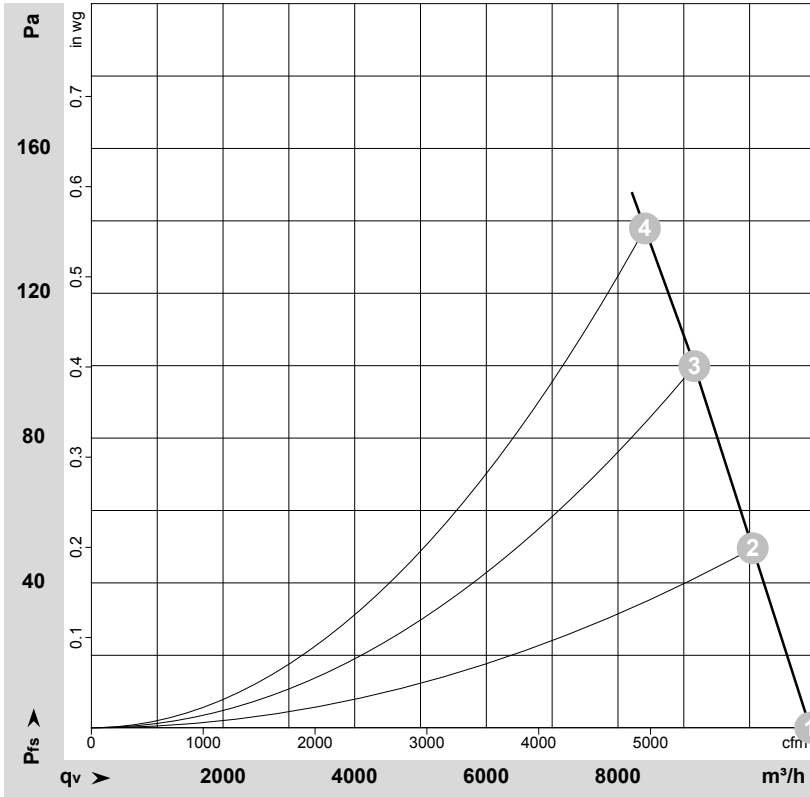

$\rho = 1.15 \text{ kg/m}^3 \pm 2 \%$

Measurement: LU-110160-1

Air performance measured according to ISO 5801 installation category A. For detailed information on the measurement setup, contact ebm-papst. Intake sound level: Sound power level according to ISO 13347 / sound pressure level measured at 1 m distance from fan axis. The values given are valid under the specified measuring conditions and may vary due to conditions of installation. For deviations from the standard configuration, the parameters have to be checked on the installed unit.

Measured values

	Wired	U	f	n	P _e	I	LpA _{in}	LwA _{in}	LwA _{out}	q _v	p _{fs}	q _v	p _{fs}
		V	Hz	min ⁻¹	W	A	dB(A)	dB(A)	dB(A)	m ³ /h	Pa	cfm	in. wg
1	Δ	460	60	1680	854	1.41	71	79	79	10920	0	6430	0.00
2	Δ	460	60	1670	930	1.49	70	77	77	10045	50	5915	0.20
3	Δ	460	60	1655	1008	1.58	68	75	75	9160	100	5390	0.40
4	Δ	460	60	1640	1060	1.64	68	75	75	8410	138	4950	0.55

Wired = Wiring · U = Voltage · f = Frequency · n = Speed (rpm) · P_e = Power consumption · I = Current draw · LpA_{in} = Sound pressure level intake side · LwA_{in} = Sound power level intake side
 LwA_{out} = Sound power level outlet side · q_v = Air flow · p_{fs} = Pressure increase

