

A4D500-AE03-02 ebmpapst Datasheet

sales@fansco.com

www.fansco.com

Limited partnership · Headquarters Muldingen

Amtsgericht (court of registration) Stuttgart · HRA 590344

General partner Elektrobau Muldingen GmbH · Headquarters Muldingen

Amtsgericht (court of registration) Stuttgart · HRB 590142



Nominal data

Type	A4D500-AE03-02				
Motor	M4D110-GF				
Phase		3~	3~	3~	3~
Nominal voltage	VAC	400	400	480	480
Wiring		Δ	Y	Δ	Y
Frequency	Hz	50	50	60	60
Method of obtaining data		ml	ml	ml	ml
Valid for approval/standard		CE	CE	CE	CE
Speed (rpm)	min ⁻¹	1360	1110	1600	1240
Power consumption	W	690	490	1100	740
Current draw	A	1.43	0.86	1.72	1.08
Max. back pressure	Pa	160	105	215	125
Max. back pressure	inH ₂ O	0.64	0.42	0.86	0.5
Min. ambient temperature	°C	-40	-40	-40	-40
Max. ambient temperature	°C	90	90	55	55
Starting current	A	6.5		7.5	

ml = Max. load · me = Max. efficiency · fa = Free air · cs = Customer specification · ce = Customer equipment
Subject to change

Data according to ErP Directive

		Actual	Req. 2015			
01 Overall efficiency η_{es}	%	34.8	32.5	09 Power consumption P_e	kW	0.66
02 Measurement category		A		09 Air flow q_v	m ³ /h	6035
03 Efficiency category		Static		09 Pressure increase p_{fs}	Pa	138
04 Efficiency grade N		42.3	40	10 Speed (rpm) n	min ⁻¹	1365
05 Variable speed drive		No		11 Specific ratio*		1.00

Data obtained at optimum efficiency level.
The ErP data is determined using a motor-impeller combination in a standardized measurement setup.

* Specific ratio = $1 + p_s / 100\,000\text{ Pa}$

LU-70503



Technical description

Weight	10.2 kg
Fan size	500 mm
Rotor surface	Cast in aluminum
Terminal box material	PP plastic
Blade material	Sheet aluminum
Number of blades	5
Blade pitch	-5°
Airflow direction	"A"
Direction of rotation	Clockwise, viewed toward rotor
Degree of protection	IP54
Insulation class	"F"
Moisture (F) / Environmental (H) protection class	H2
Max. permitted ambient temp. for motor (transport/storage)	+ 80 °C
Min. permitted ambient temp. for motor (transport/storage)	- 40 °C
Installation position	Shaft horizontal or rotor on bottom; rotor on top on request
Condensation drainage holes	On rotor side
Mode	S1
Motor bearing	Ball bearing
Touch current according to IEC 60990 (measuring circuit Fig. 4, TN system)	<= 3.5 mA
Electrical hookup	Via terminal box
Motor protection	Thermal overload protector (TOP) with basic insulation
With cable	Axial
Protection class	I (with customer connection of protective earth)
Conformity with standards	EN 61800-5-1; CE
Approval	VDE; GOST; EAC

AC axial fan

sickle-shaped blades (S series)

Product drawing

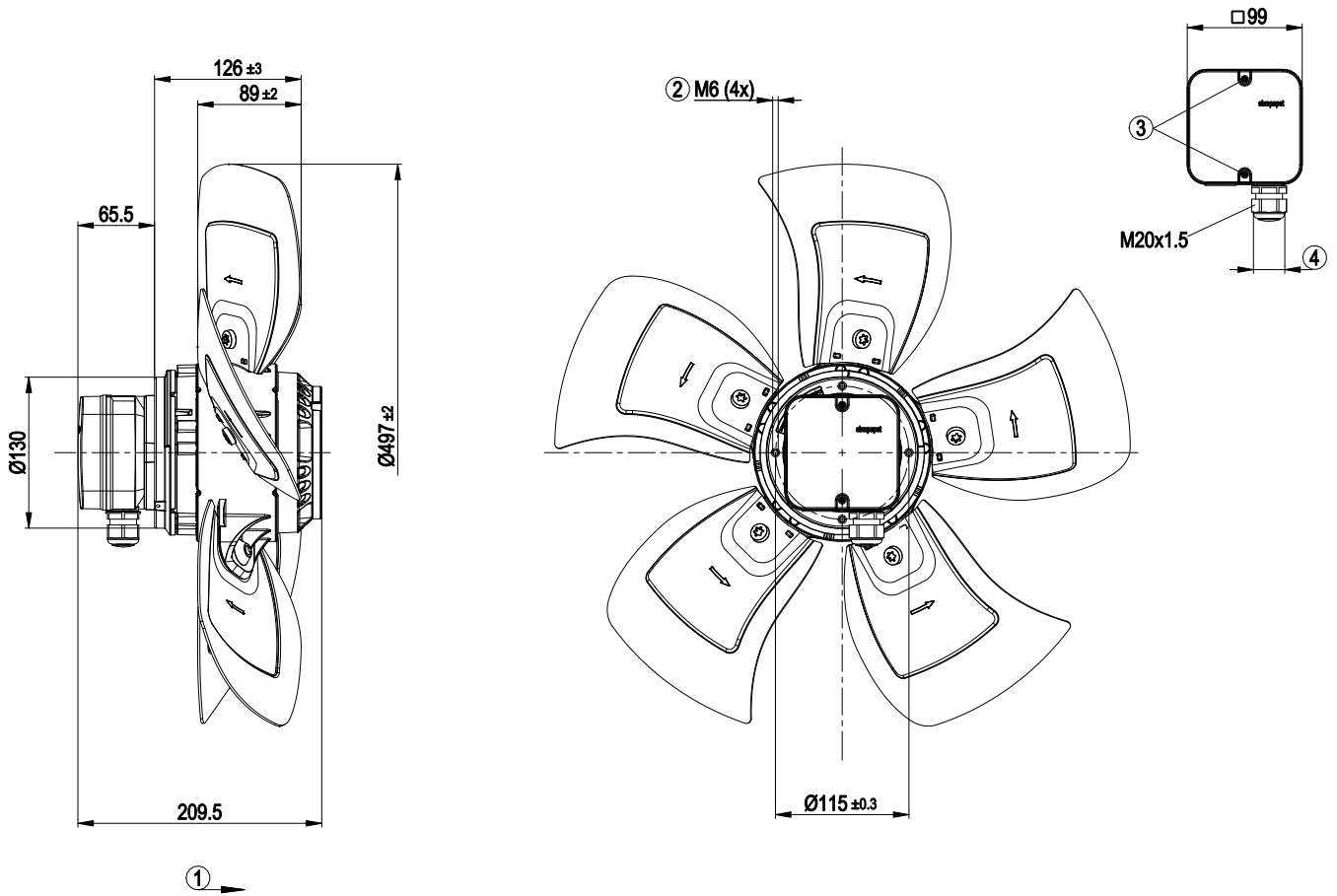

1	Direction of air flow "A"
2	Max. clearance for screw 12 mm
3	Tightening torque 1.5 \pm 0.2 Nm
4	Cable diameter min. 6 mm, max. 12 mm, tightening torque 2.0 \pm 0.3 Nm



AC axial fan

sickle-shaped blades (S series)

Connection diagram



Δ	Delta connection	Y	Star connection	L1	= U1 = black
L2	= V1 = blue	L3	= W1 = brown	W2	yellow
U2	green	V2	white	TOP	2x gray
PE	green/yellow				



Curves: Air performance 50 Hz Y

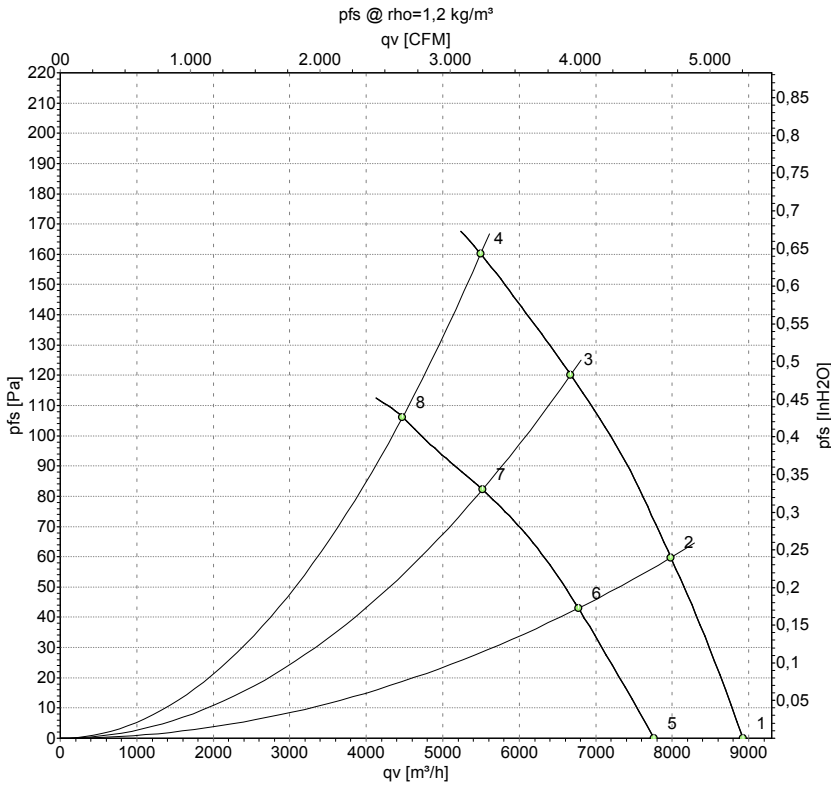

Measurement: LU-70503-1
Measurement: LU-70507-1

Air performance measured according to ISO 5801 installation category A. For detailed information on the measurement setup, contact ebmpapst. Intake sound level: Sound power level according to ISO 13347 / sound pressure level measured at 1 m distance from fan axis. The values given are valid under the specified measuring conditions and may vary due to conditions of installation. For deviations from the standard configuration, the parameters have to be checked on the installed unit.

Measured values

	Wired	U	f	n	P _e	I	qv	p _{fs}	qv	p _{fs}
		V	Hz	min ⁻¹	W	A	m ³ /h	Pa	CFM	inH2O
1	Δ	400	50	1405	512	1.21	8930	0	5255	0.00
2	Δ	400	50	1385	587	1.29	7980	60	4700	0.24
3	Δ	400	50	1370	644	1.34	6670	120	3925	0.48
4	Δ	400	50	1360	690	1.43	5495	160	3235	0.64
5	Y	400	50	1215	395	0.67	7765	0	4570	0.00
6	Y	400	50	1175	433	0.73	6775	43	3985	0.17
7	Y	400	50	1135	464	0.79	5520	83	3250	0.33
8	Y	400	50	1110	490	0.86	4475	105	2635	0.42

Wired = Wiring · U = Power supply · f = Frequency · n = Speed (rpm) · P_e = Power consumption · I = Current draw · qv = Air flow · p_{fs} = Pressure increase



Curves: Air performance 60 Hz

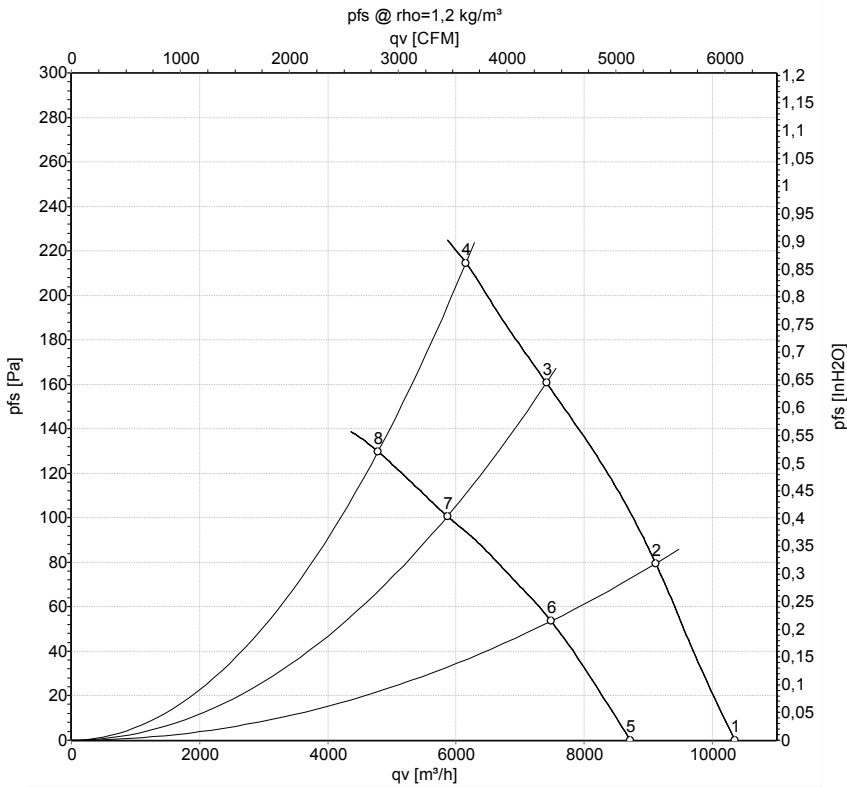

Measurement: LU-100859-1
Measurement: LU-100861-1

Air performance measured according to ISO 5801 installation category A. For detailed information on the measurement setup, contact ebm-papst. Intake sound level: Sound power level according to ISO 13347 / sound pressure level measured at 1 m distance from fan axis. The values given are valid under the specified measuring conditions and may vary due to conditions of installation. For deviations from the standard configuration, the parameters have to be checked on the installed unit.

Measured values

	Wired	U	f	n	P _e	I	qv	p _{fs}	qv	p _{fs}
		V	Hz	min ⁻¹	W	A	m ³ /h	Pa	CFM	inH2O
1	Δ	480	60	1665	788	1.32	10350	0	6090	0.00
2	Δ	480	60	1645	905	1.43	9115	80	5365	0.32
3	Δ	480	60	1620	1012	1.55	7410	160	4360	0.64
4	Δ	480	60	1600	1100	1.72	6155	215	3620	0.86
5	Y	480	60	1405	601	0.84	8720	0	5130	0.00
6	Y	480	60	1340	661	0.92	7485	55	4405	0.22
7	Y	480	60	1285	705	0.99	5865	100	3455	0.40
8	Y	480	60	1240	740	1.08	4785	130	2815	0.52

Wired = Wiring · U = Power supply · f = Frequency · n = Speed (rpm) · P_e = Power consumption · I = Current draw · qv = Air flow · p_{fs} = Pressure increase

