

# AC axial fan

sickled blades (S series)

A4D500-AD03-07 ebmpapst Datasheet  
 sales@fansco.com  
 www.fansco.com

Limited partnership · Headquarters Mulfingen  
 County court Stuttgart · HRA 590344

General partner Elektrobau Mulfingen GmbH · Headquarters Mulfingen  
 County court Stuttgart · HRB 590142



## Nominal data

Type	A4D500-AD03-07				
Motor	M4D110-GF				
Phase		3~	3~	3~	3~
Nominal voltage	VAC	400	400	480	480
Connection		Δ	Y	Δ	Y
Frequency	Hz	50	50	60	60
Type of data definition		ml	ml	ml	ml
Valid for approval / standard		CE	CE	CE	CE
Speed	min <sup>-1</sup>	1325	1035	1570	1170
Power input	W	820	550	1220	770
Current draw	A	1.59	0.95	1.86	1.13
Max. back pressure	Pa	160	100	150	84
Min. ambient temperature	°C	-40	-40	-40	-40
Max. ambient temperature	°C	80	80	50	50
Starting current	A	6.5	2	7.5	2.2
Maximum safe operating speed	min <sup>-1</sup>	1620	1620	1620	1620

ml = Max. load · me = Max. efficiency · fa = Running at free air · cs = Customer specs · cu = Customer unit  
 Subject to alterations

## Data according to ErP directive

Installation category	A
Efficiency category	Static
Variable speed drive	No
Specific ratio*	1.00

\* Specific ratio =  $1 + p_g / 100\,000\text{ Pa}$

		Actual	Request 2013	Request 2015
Overall efficiency $\eta_{es}$	%	31.3	29	33
Efficiency grade N		38.3	36	40
Power input $P_e$	kW	0.77		
Air flow $q_v$	m <sup>3</sup> /h	6045		
Pressure increase $p_{fs}$	Pa	144		
Speed n	min <sup>-1</sup>	1335		

Data definition with optimum efficiency. LU-100710  
 The ErP data is determined using a motor-impeller combination in a standardised measurement configuration.



# AC axial fan

sickled blades (S series)

## Technical features

Mass	10.2 kg
Size	500 mm
Surface of rotor	Cast in aluminium
Material of terminal box	PP plastic
Material of blades	Aluminium sheet
Number of blades	5
Blade angle	0
Direction of air flow	"V"
Direction of rotation	Counter-clockwise, seen on rotor
Type of protection	IP 54
Insulation class	"F"
Humidity class	F4-2
Max. permissible ambient motor temp. (transp./ storage)	+ 80 °C
Min. permissible ambient motor temp. (transp./storage)	- 40 °C
Mounting position	Shaft horizontal or rotor on bottom; rotor on top on request
Condensate discharge holes	Rotor-side
Operation mode	S1
Motor bearing	Ball bearing with anti-freezing grease
Touch current acc. IEC 60990 (measuring network Fig. 4, TN system)	<= 3.5 mA
Electrical leads	Via terminal box
Motor protection	Thermal overload protector (TOP) brought out
Cable exit	Axial
Protection class	I (if protective earth is connected by customer)
Product conforming to standard	EN 61800-5-1; CE



Product drawing

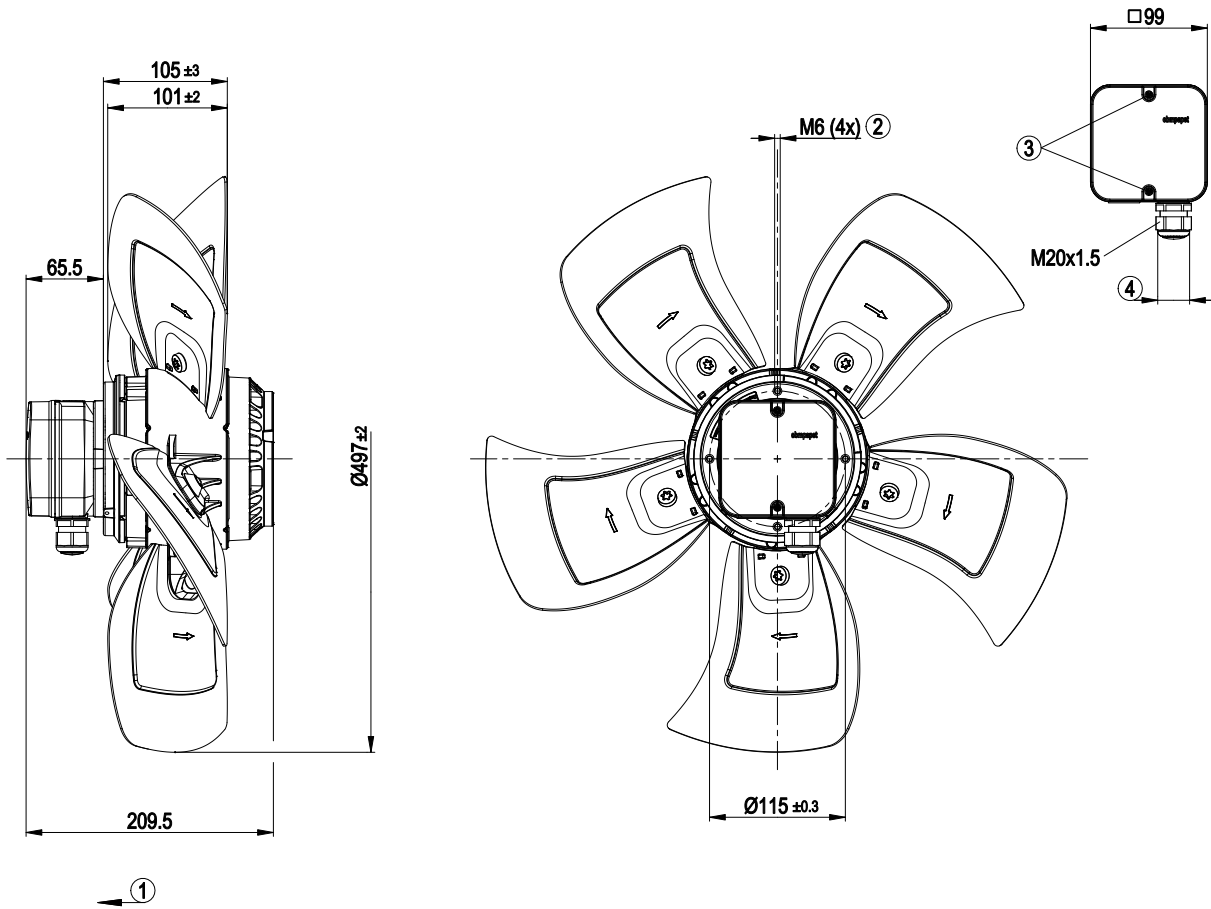

1	Direction of air flow "V"
2	Depth of screw max. 12 mm
3	Tightening torque 1.5±0.2 Nm
4	Cable diameter: min. 6 mm, max. 12 mm, tightening torque 2±0.3 Nm

Connection screen

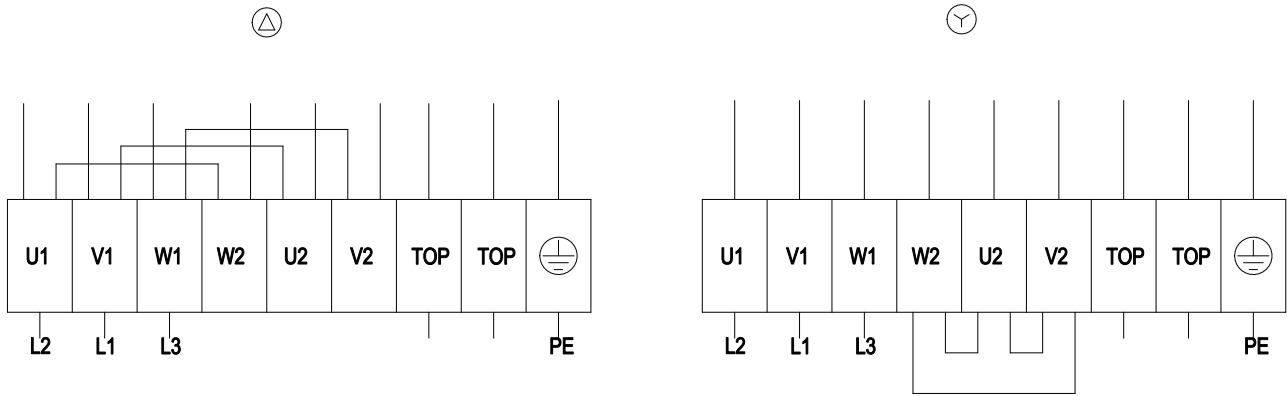

Δ	Delta connection	Y	Star connection	L1	= V1 = blue
L2	= U1 = black	L3	= W1 = brown	W2	yellow
U2	green	V2	white	TOP	2 x grey
PE	green/yellow				

## Charts: Air flow 50 Hz Δ

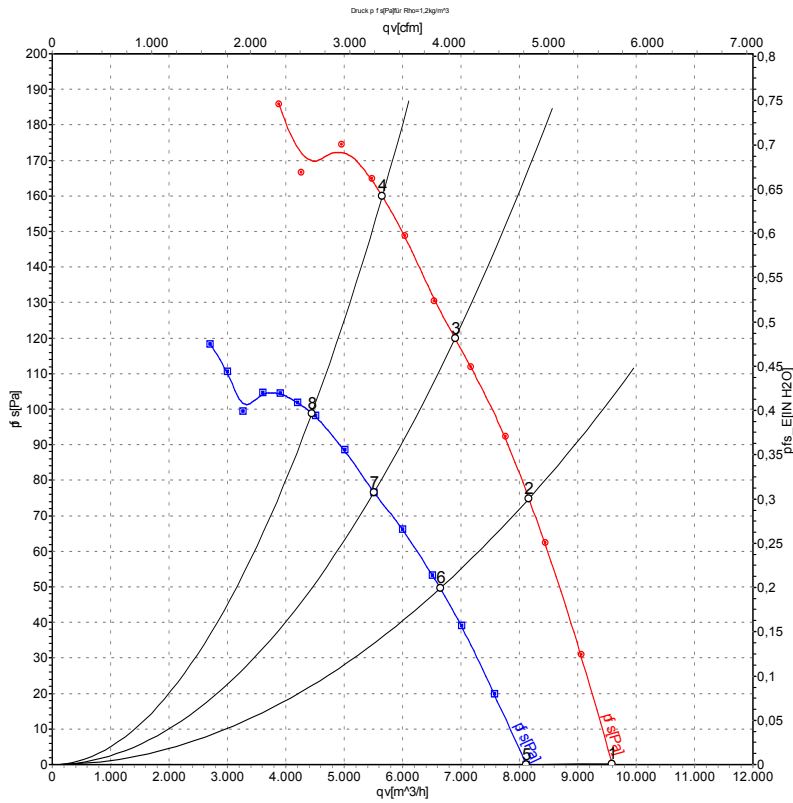

Air performance measured as per ISO 5801 Installation category A. For detailed information on the measuring set-up, please contact ebmpapst. Suction-side noise levels: LwA measured as per ISO 13347 / LpA measured with 1m distance to fan axis. The values given are valid under the measuring conditions mentioned above and may vary according to the actual installation situation. With any deviation from the standard set-up, the specific values have to be checked and reviewed with the unit installed.

## Measured values

	Conn.	U	f	n	P <sub>e</sub>	I	LpA <sub>in</sub>	LwA <sub>in</sub>	qv	p <sub>fs</sub>
		V	Hz	min <sup>-1</sup>	W	A	dB(A)	dB(A)	m <sup>3</sup> /h	Pa
1	Δ	400	50	1380	620	1.30	71	77	9590	0
2	Δ	400	50	1360	700	1.38	71	77	8160	75
3	Δ	400	50	1345	749	1.44	71	78	6900	120
4	Δ	400	50	1325	820	1.59	73	80	5655	160
5	Y	400	50	1160	455	0.77	73	80	8120	0
6	Y	400	50	1105	498	0.84	73	80	6645	50
7	Y	400	50	1075	519	0.87	73	80	5515	76
8	Y	400	50	1035	550	0.95	73	80	4445	100

Conn. = Connection · U = Supply voltage · f = Frequency · n = Speed · P<sub>e</sub> = Power input · I = Current draw · LpA<sub>in</sub> = Sound pressure level inlet side · LwA<sub>in</sub> = Sound power level inlet side  
 qv = Air flow · p<sub>fs</sub> = Pressure increase



## Charts: Air flow 60 Hz Δ

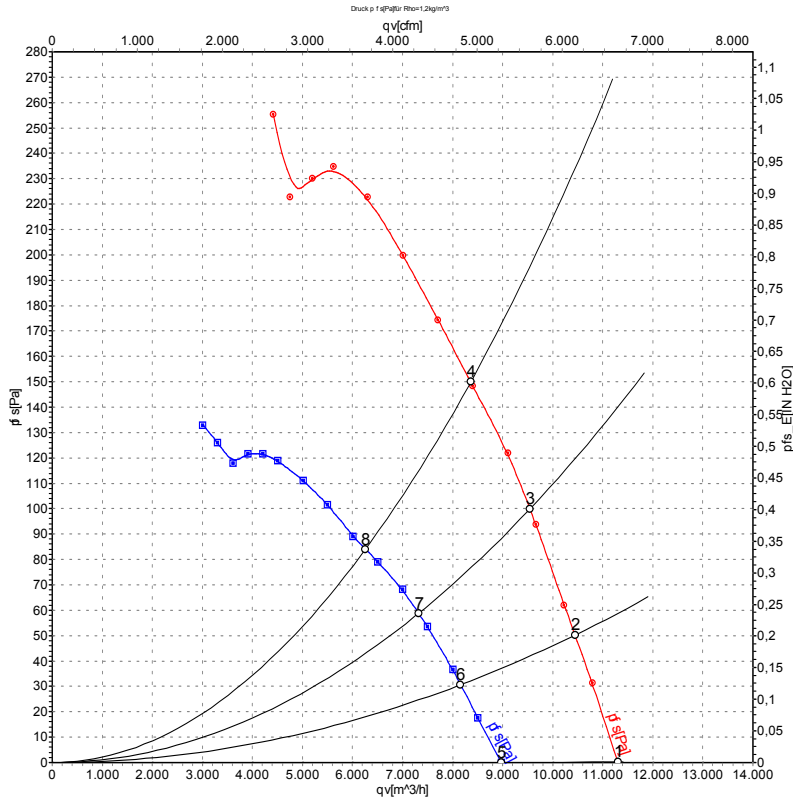

Air performance measured as per ISO 5801 Installation category A. For detailed information on the measuring set-up, please contact ebmpapst. Suction-side noise levels: LwA measured as per ISO 13347 / LpA measured with 1m distance to fan axis. The values given are valid under the measuring conditions mentioned above and may vary according to the actual installation situation. With any deviation from the standard set-up, the specific values have to be checked and reviewed with the unit installed.

## Measured values

	Conn.	U	f	n	P <sub>e</sub>	I	LpA <sub>in</sub>	LwA <sub>in</sub>	qv	p <sub>fs</sub>
		V	Hz	min <sup>-1</sup>	W	A	dB(A)	dB(A)	m <sup>3</sup> /h	Pa
1	Δ	480	60	1620	1000	1.55	74	80	11300	0
2	Δ	480	60	1605	1069	1.63	74	80	10440	50
3	Δ	480	60	1590	1138	1.70	74	80	9545	100
4	Δ	480	60	1570	1220	1.86	75	81	8360	150
5	Y	480	60	1280	695	0.98	75	81	8970	0
6	Y	480	60	1250	723	1.02	75	81	8160	31
7	Y	480	60	1210	748	1.06	75	81	7320	59
8	Y	480	60	1170	770	1.13	75	81	6260	84

Conn. = Connection · U = Supply voltage · f = Frequency · n = Speed · P<sub>e</sub> = Power input · I = Current draw · LpA<sub>in</sub> = Sound pressure level inlet side · LwA<sub>in</sub> = Sound power level inlet side  
 qv = Air flow · p<sub>fs</sub> = Pressure increase

