

A4D450-BG14-51 ebmpapst Datasheet

sales@fansco.com

www.fansco.com

Limited partnership · Headquarters Muldingen

Amtsgericht (court of registration) Stuttgart · HRA 590344

General partner Elektrobau Muldingen GmbH · Headquarters Muldingen

Amtsgericht (court of registration) Stuttgart · HRB 590142



Nominal data

Type	A4D450-BG14-51				
Motor	M4D094-HA				
Phase		3~	3~	3~	3~
Nominal voltage	VAC	400	400	400	400
Wiring		Δ	Y	Δ	Y
Frequency	Hz	50	50	60	60
Method of obtaining data		ml	ml	ml	ml
Valid for approval/standard		CE	CE	CE	CE
Speed (rpm)	min ⁻¹	1330	1000	1540	1060
Power consumption	W	585	390	660	400
Current draw	A	1.1	0.67	1.16	0.7
Max. back pressure	Pa	200	110	110	55
Max. back pressure	inH ₂ O	0.8	0.44	0.44	0.22
Max. ambient temperature	°C	70	70	50	50
Starting current	A	3.9	1.3	3.5	1.2

ml = Max. load · me = Max. efficiency · fa = Free air · cs = Customer specification · ce = Customer equipment

Subject to change

Data according to ErP Directive

		Actual	Req. 2015		
01 Overall efficiency η_{es}	%	32.1	31.7	09 Power consumption P_e	kW 0.49
02 Measurement category	A			09 Air flow q_v	m ³ /h 4750
03 Efficiency category	Static			09 Pressure increase p_{fs}	Pa 120
04 Efficiency grade N	40.4	40		10 Speed (rpm) n	min ⁻¹ 1370
05 Variable speed drive	No			11 Specific ratio*	1.00

Data obtained at optimum efficiency level.

The ErP data is determined using a motor-impeller combination in a standardized measurement setup.

* Specific ratio = $1 + p_g / 100\,000\text{ Pa}$

LU-58721



Technical description

Fan size	450 mm
Rotor surface	Painted black
Terminal box material	ABS plastic, black
Blade material	Sheet aluminum
Number of blades	5
Blade pitch	0°
Airflow direction	"V"
Direction of rotation	Counterclockwise, viewed toward rotor
Degree of protection	IP54
Insulation class	"F"
Moisture (F) / Environmental (H) protection class	F4-1
Max. permitted ambient temp. for motor (transport/storage)	+ 80 °C
Min. permitted ambient temp. for motor (transport/storage)	- 40 °C
Installation position	Shaft horizontal or rotor on bottom; rotor on top on request
Condensation drainage holes	On rotor side
Mode	S1
Motor bearing	Ball bearing
Touch current according to IEC 60990 (measuring circuit Fig. 4, TN system)	<= 3.5 mA
Electrical hookup	Via terminal box
Motor protection	Thermal overload protector (TOP) with basic insulation
Protection class	I (with customer connection of protective earth)
Conformity with standards	EN 60034-1 (2004); CE

Product drawing

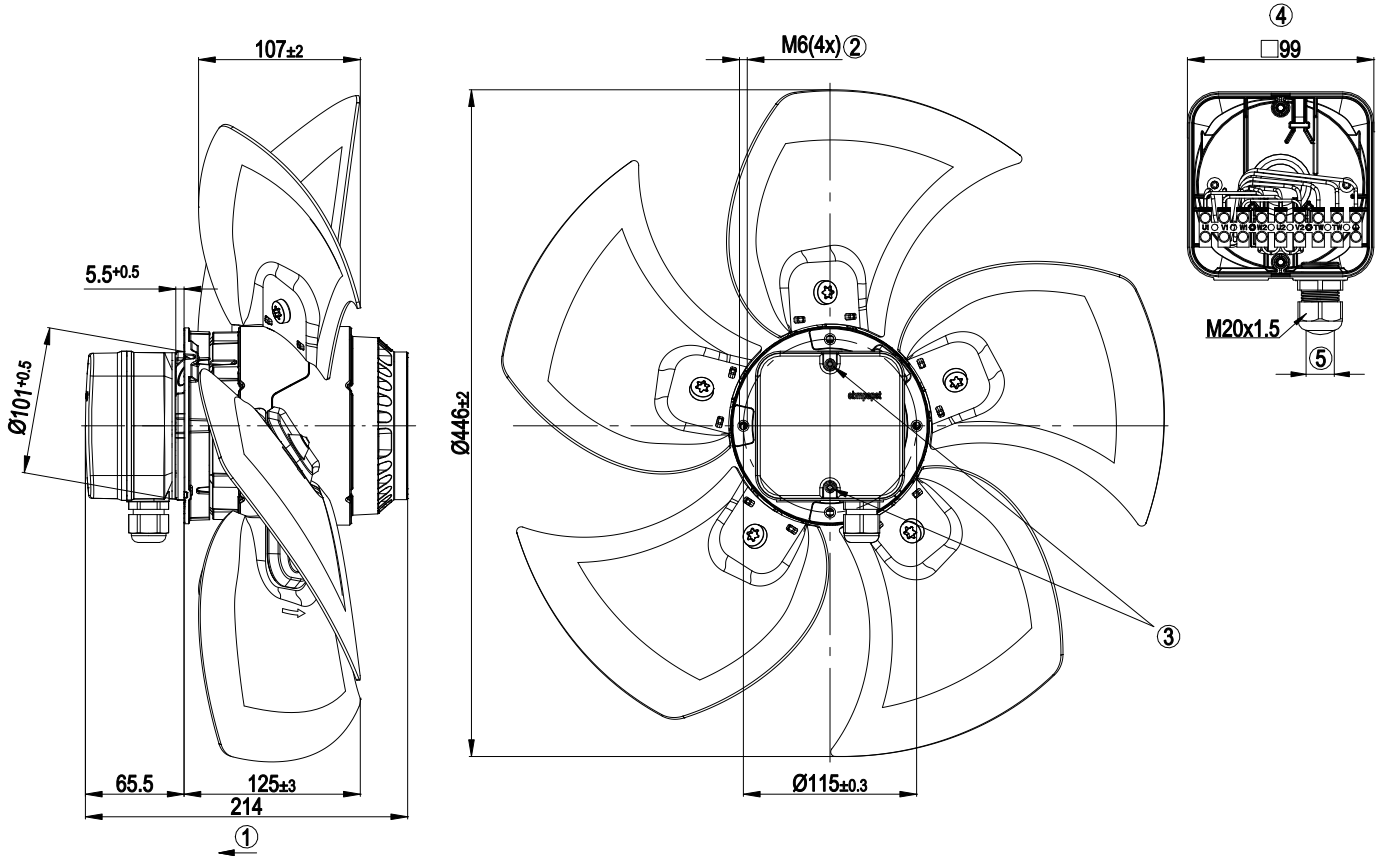

1	Direction of air flow "V"
2	Max. clearance for screw 12 mm
3	Tightening torque 0.8±0.15 Nm
4	Shown without terminal box cover
5	Cable diameter: min. 6 mm, max. 12 mm; tightening torque 2±0.15 Nm

Connection diagram



Δ	Delta connection	Y	Star connection	L1	= U1 = black
L2	= V1 = blue	L3	= W1 = brown	W2	yellow
U2	green	V2	white	TOP	2x gray
PE	green/yellow				

Curves: Air performance 50 Hz Δ

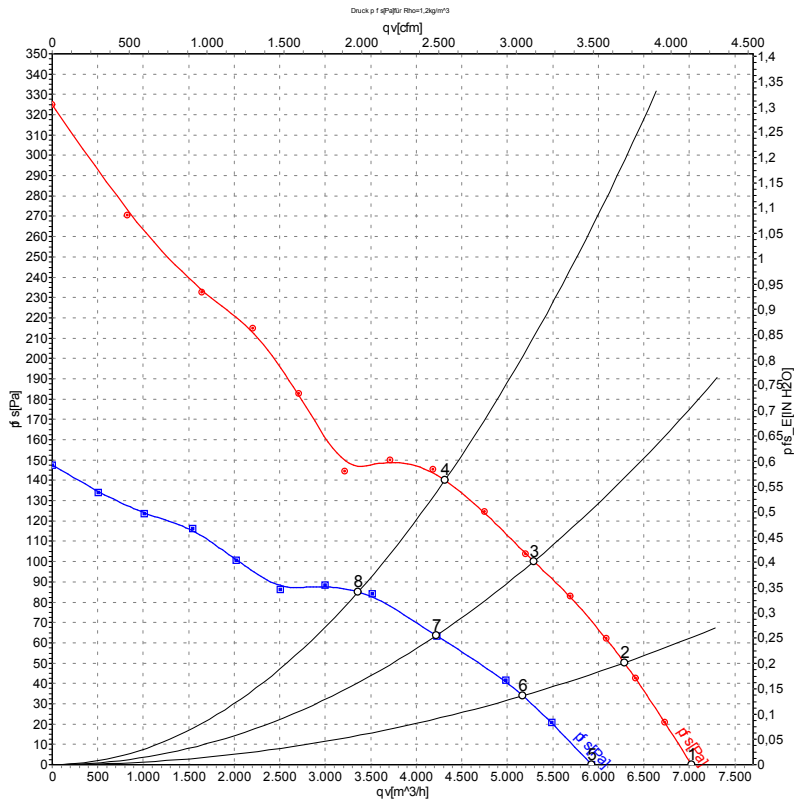

Measurement: LU-58721-1
Measurement: LU-58724-1

Air performance measured according to ISO 5801 installation category A. For detailed information on the measurement setup, contact ebm-papst. Intake sound level: Sound power level according to ISO 13347 / sound pressure level measured at 1 m distance from fan axis. The values given are valid under the specified measuring conditions and may vary due to conditions of installation. For deviations from the standard configuration, the parameters have to be checked on the installed unit.

Measured values

	Wired	U	f	n	P _e	I	qv	p _{fs}	qv	p _{fs}
		V	Hz	min ⁻¹	W	A	m ³ /h	Pa	CFM	inH ₂ O
1	Δ	400	50	1400	399	0.94	7025	0	4135	0.00
2	Δ	400	50	1385	438	0.98	6285	50	3700	0.20
3	Δ	400	50	1375	474	1.02	5290	100	3115	0.40
4	Δ	400	50	1350	520	1.10	4315	140	2540	0.56
5	Y	400	50	1180	304	0.52	5925	0	3485	0.00
6	Y	400	50	1140	329	0.57	5170	34	3040	0.14
7	Y	400	50	1095	350	0.60	4220	64	2485	0.26
8	Y	400	50	1050	370	0.65	3360	85	1980	0.34

Wired = Wiring · U = Power supply · f = Frequency · n = Speed (rpm) · P_e = Power consumption · I = Current draw · qv = Air flow · p_{fs} = Pressure increase



Curves: Air performance 60 Hz Δ

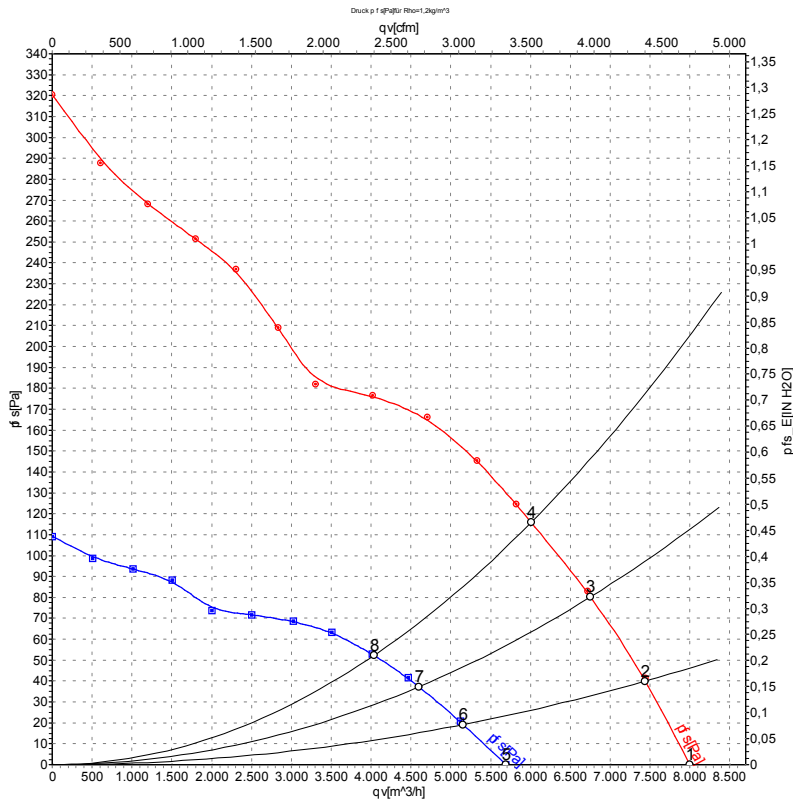

Measurement: LU-58722-1
Measurement: LU-58725-1

Air performance measured according to ISO 5801 installation category A. For detailed information on the measurement setup, contact ebm-papst. Intake sound level: Sound power level according to ISO 13347 / sound pressure level measured at 1 m distance from fan axis. The values given are valid under the specified measuring conditions and may vary due to conditions of installation. For deviations from the standard configuration, the parameters have to be checked on the installed unit.

Measured values

	Wired	U	f	n	P _e	I	qv	p _{fs}	qv	p _{fs}
		V	Hz	min ⁻¹	W	A	m ³ /h	Pa	CFM	inH ₂ O
1	Δ	400	60	1600	610	1.12	7995	0	4705	0.00
2	Δ	400	60	1560	648	1.19	7435	40	4375	0.16
3	Δ	400	60	1540	683	1.24	6750	80	3975	0.32
4	Δ	400	60	1525	715	1.30	6010	115	3535	0.46
5		400	60	1130	390	0.70	5690	0	3350	0.00
6		400	60	1085	398	0.71	5155	20	3035	0.08
7		400	60	1050	405	0.73	4600	37	2705	0.15
8		400	60	1020	411	0.74	4035	52	2375	0.21

Wired = Wiring · U = Power supply · f = Frequency · n = Speed (rpm) · P_e = Power consumption · I = Current draw · qv = Air flow · p_{fs} = Pressure increase

