



A4D450-BA14-02 ebmpapst Datasheet

sales@fansco.com

www.fansco.com

Nominal data

Type	A4D450-BA14-02				
Motor	M4D094-HA				
Phase		3~	3~	3~	3~
Nominal voltage	VAC	400	400	400	400
Wiring		Δ	Y	Δ	Y
Frequency	Hz	50	50	60	60
Method of obtaining data		ml	ml	ml	ml
Valid for approval/standard		CE	CE	CE	CE
Speed (rpm)	min ⁻¹	1330	1000	1540	1060
Power consumption	W	585	390	660	400
Current draw	A	1.1	0.67	1.16	0.7
Max. back pressure	Pa	200	110	110	55
Max. back pressure	in. wg	0.8	0.44	0.44	0.22
Min. ambient temperature	°C	-40	-40	-40	-40
Max. ambient temperature	°C	70	70	50	50
Starting current	A	3.9	1.3	3.5	1.2

ml = Max. load · me = Max. efficiency · fa = Free air · cs = Customer specification · ce = Customer equipment
Subject to change

Data according to Commission Regulation (EU) 327/2011 (EN 17166)

		Actual	Req. 2015		
01 Overall efficiency η_{es}	%	39.4	31.3	09 Power consumption P_e	kW 0.42
02 Measurement category		A		09 Air flow q_v	m ³ /h 4500
03 Efficiency category		Static		09 Pressure increase p_{fs}	Pa 135
04 Efficiency grade N		48.1	40	10 Speed (rpm) n	min ⁻¹ 1385
05 Variable speed drive		No		11 Specific ratio*	1.00

Data obtained at optimum efficiency level.
The ErP data is determined using a motor-impeller combination in a standardized measurement setup.

* Specific ratio = $1 + p_{fs} / 100\,000\text{ Pa}$

LU-106884



Technical description

Weight	7.8 kg
Size	450 mm
Motor size	94
Rotor surface	Painted black
Terminal box material	PP plastic
Blade material	Sheet steel, painted black
Number of blades	5
Airflow direction	A
Direction of rotation	Clockwise, viewed toward rotor
Degree of protection	IP54
Insulation class	"F"
Moisture (F) / Environmental (H) protection class	H2
Ambient temperature note	Occasional start-up at temperatures between -40°C and -25°C is permitted. For continuous operation at ambient temperatures below -25°C (such as refrigeration applications), use must be made of a fan design with special low-temperature bearings.
Max. permitted ambient temp. for motor (transport/storage)	+80 °C
Min. permitted ambient temp. for motor (transport/storage)	-40 °C
Installation position	Shaft horizontal or rotor on bottom; rotor on top on request
Condensation drainage holes	On rotor side
Mode	S1
Motor bearing	Ball bearing
Touch current according to IEC 60990 (measuring circuit Fig. 4, TN system)	<= 3.5 mA
Electrical hookup	Terminal box
Motor protection	Thermal overload protector (TOP) with basic insulation
Protection class	I (with customer connection of protective earth)
Conformity with standards	EN 60034-1 (2010); CE
Approval	CCC; EAC

AC axial fan

sickle-shaped blades (S series)

Product drawing

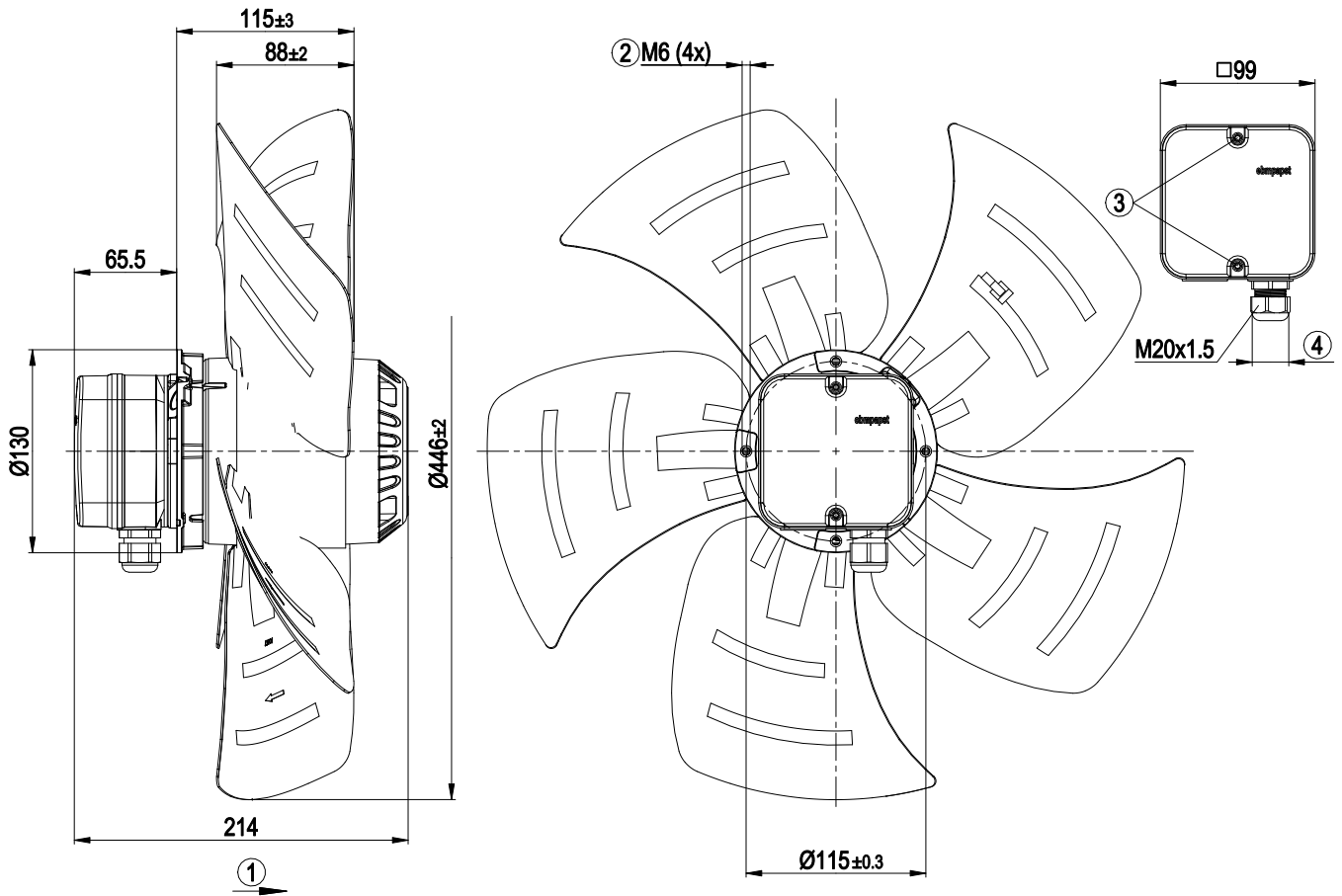

1	Direction of air flow "A"
2	Max. clearance for screw 12 mm
3	Tightening torque 1.5 ± 0.2 Nm
4	Cable diameter min. 6 mm, max. 12 mm, tightening torque 2 ± 0.3 Nm



AC axial fan

sickle-shaped blades (S series)

Connection diagram

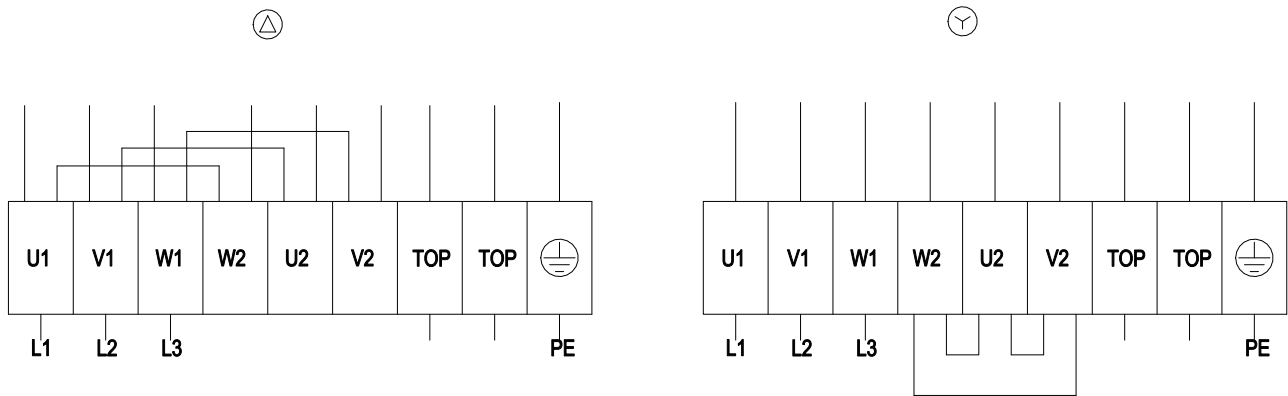

Δ	Delta connection	Y	Star connection	L1	= U1 = black
L2	= V1 = blue	L3	= W1 = brown	W2	yellow
U2	green	V2	white	TOP	2x gray
PE	green/yellow				



Curves: Air performance 50 Hz

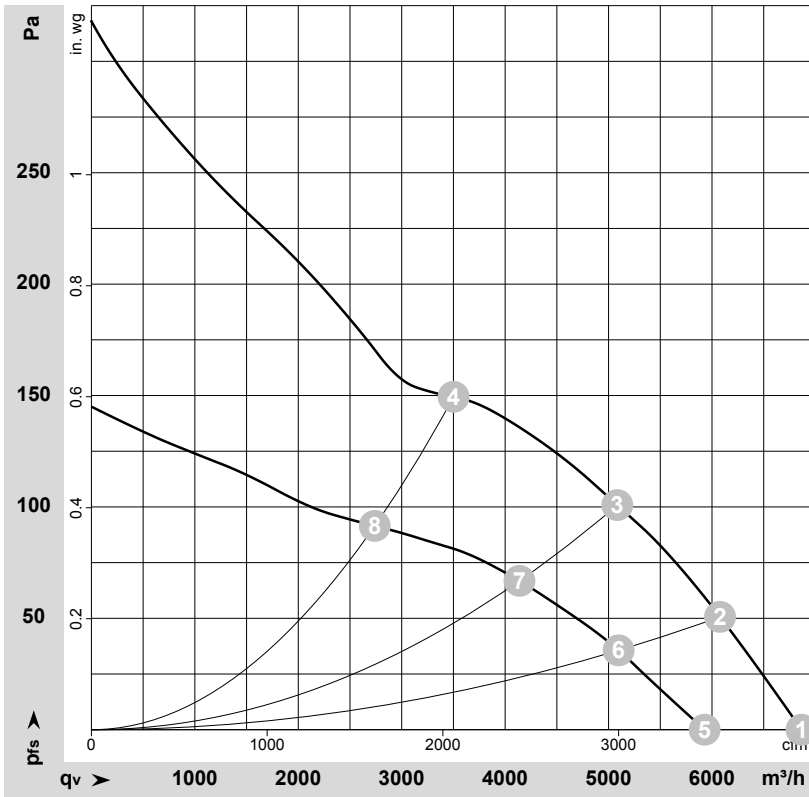

$\rho = 1.15 \text{ kg/m}^3 \pm 2 \%$

Measurement: LU-54525-1
Measurement: LU-54528-1

Air performance measured according to ISO 5801 installation category A. For detailed information on the measurement setup, contact ebm-papst. Intake sound level: Sound power level according to ISO 13347 / sound pressure level measured at 1 m distance from fan axis. The values given are valid under the specified measuring conditions and may vary due to conditions of installation. For deviations from the standard configuration, the parameters have to be checked on the installed unit.

Measured values

	Wired	U	f	n	P _e	I	q _v	P _{fs}	q _v	P _{fs}
		V	Hz	min ⁻¹	W	A	m ³ /h	Pa	cfm	in. wg
1	Δ	400	50	1410	355	0.85	6865	0	4040	0.00
2	Δ	400	50	1400	399	0.90	6080	50	3575	0.20
3	Δ	400	50	1385	441	0.95	5085	100	2990	0.40
4	Δ	400	50	1365	498	1.01	3500	150	2060	0.60
5	Y	400	50	1220	270	0.47	5930	0	3490	0.00
6	Y	400	50	1180	301	0.51	5095	36	3000	0.14
7	Y	400	50	1130	326	0.55	4140	67	2435	0.27
8	Y	400	50	1070	359	0.61	2740	91	1610	0.37

Wired = Wiring · U = Voltage · f = Frequency · n = Speed (rpm) · P_e = Power consumption · I = Current draw · q_v = Air flow · P_{fs} = Pressure increase



Curves: Air performance 60 Hz

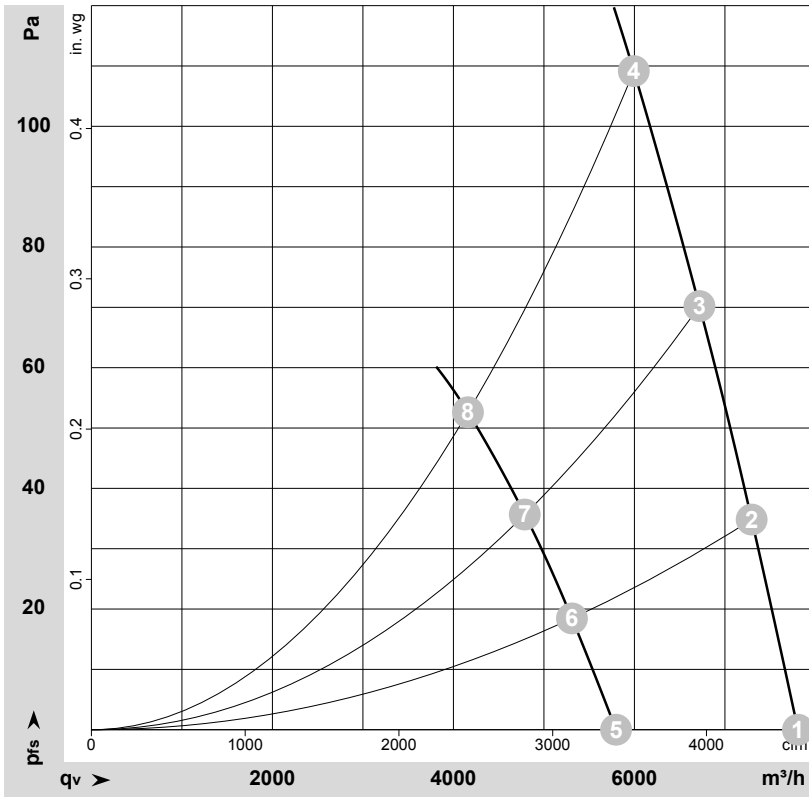

$\rho = 1.15 \text{ kg/m}^3 \pm 2 \%$

Measurement: LU-54526-1
Measurement: LU-54529-1

Air performance measured according to ISO 5801 installation category A. For detailed information on the measurement setup, contact ebmpapst. Intake sound level: Sound power level according to ISO 13347 / sound pressure level measured at 1 m distance from fan axis. The values given are valid under the specified measuring conditions and may vary due to conditions of installation. For deviations from the standard configuration, the parameters have to be checked on the installed unit.

Measured values

	Wired	U	f	n	P _e	I	q _v	P _{fs}	q _v	P _{fs}
		V	Hz	min ⁻¹	W	A	m ³ /h	Pa	cfm	in. wg
1	Δ	400	60	1610	535	0.98	7805	0	4595	0.00
2	Δ	400	60	1590	572	1.03	7295	35	4295	0.14
3	Δ	400	60	1570	609	1.09	6720	70	3955	0.28
4	Δ	400	60	1540	660	1.16	5995	110	3525	0.44
5	Y	400	60	1205	360	0.62	5795	0	3410	0.00
6	Y	400	60	1155	375	0.65	5310	19	3125	0.08
7	Y	400	60	1110	385	0.67	4790	36	2820	0.14
8	Y	400	60	1060	400	0.70	4160	55	2450	0.22

Wired = Wiring · U = Voltage · f = Frequency · n = Speed (rpm) · P_e = Power consumption · I = Current draw · q_v = Air flow · P_{fs} = Pressure increase

