

A4D450-AU01-02 ebmpapst Datasheet

sales@fansco.com

www.fansco.com

Limited partnership · Headquarters Muldingen

Amtsgericht (court of registration) Stuttgart · HRA 590344

General partner Elektrobau Muldingen GmbH · Headquarters Muldingen

Amtsgericht (court of registration) Stuttgart · HRB 590142



Nominal data

Type	A4D450-AU01-02				
Motor	M4D094-EA				
Phase		3~	3~	3~	3~
Nominal voltage	VAC	400	400	400	400
Wiring		Δ	Y	Δ	Y
Frequency	Hz	50	50	60	60
Method of obtaining data		ml	ml	ml	ml
Valid for approval/standard		CE	CE	CE	CE
Speed (rpm)	min ⁻¹	1250	875	1360	860
Power consumption	W	340	200	415	205
Current draw	A	0.61	0.33	0.70	0.35
Max. back pressure	Pa	120	60	85	35
Max. back pressure	inH ₂ O	0.48	0.24	0.34	0.14
Min. ambient temperature	°C	-40	-40	-40	-40
Max. ambient temperature	°C	60	60	50	50
Starting current	A	1.7	0.55	1.57	0.51

ml = Max. load · me = Max. efficiency · fa = Free air · cs = Customer specification · ce = Customer equipment
Subject to change

Data according to ErP Directive

		Actual	Req. 2015			
01 Overall efficiency η_{es}	%	32	30.4	09 Power consumption P_e	kW	0.3
02 Measurement category		A		09 Air flow q_v	m ³ /h	3610
03 Efficiency category		Static		09 Pressure increase p_{fs}	Pa	96
04 Efficiency grade N		41.6	40	10 Speed (rpm) n	min ⁻¹	1285
05 Variable speed drive		No		11 Specific ratio*		1.00

Data obtained at optimum efficiency level.
The ErP data is determined using a motor-impeller combination in a standardized measurement setup.

* Specific ratio = $1 + p_{fs} / 100\,000\text{ Pa}$

LU-72632



Technical description

Weight	4.7 kg
Fan size	450 mm
Rotor surface	Painted black
Terminal box material	ABS plastic
Blade material	Press-fitted sheet steel blank, sprayed with PP plastic
Number of blades	5
Airflow direction	"A"
Direction of rotation	Clockwise, viewed toward rotor
Degree of protection	IP54
Insulation class	"F"
Moisture (F) / Environmental (H) protection class	F4-1
Max. permitted ambient temp. for motor (transport/storage)	+80 °C
Min. permitted ambient temp. for motor (transport/storage)	-40 °C
Installation position	Shaft horizontal or rotor on bottom; rotor on top on request
Condensation drainage holes	On rotor side
Mode	S1
Motor bearing	Ball bearing
Touch current according to IEC 60990 (measuring circuit Fig. 4, TN system)	≤ 3.5 mA
Electrical hookup	Via terminal box
Motor protection	Thermal overload protector (TOP) with basic insulation
Protection class	I (with customer connection of protective earth)
Conformity with standards	EN 60034-1 (2010); CE
Approval	EAC; CCC

AC axial fan

sickle-shaped blades (S series)

Product drawing

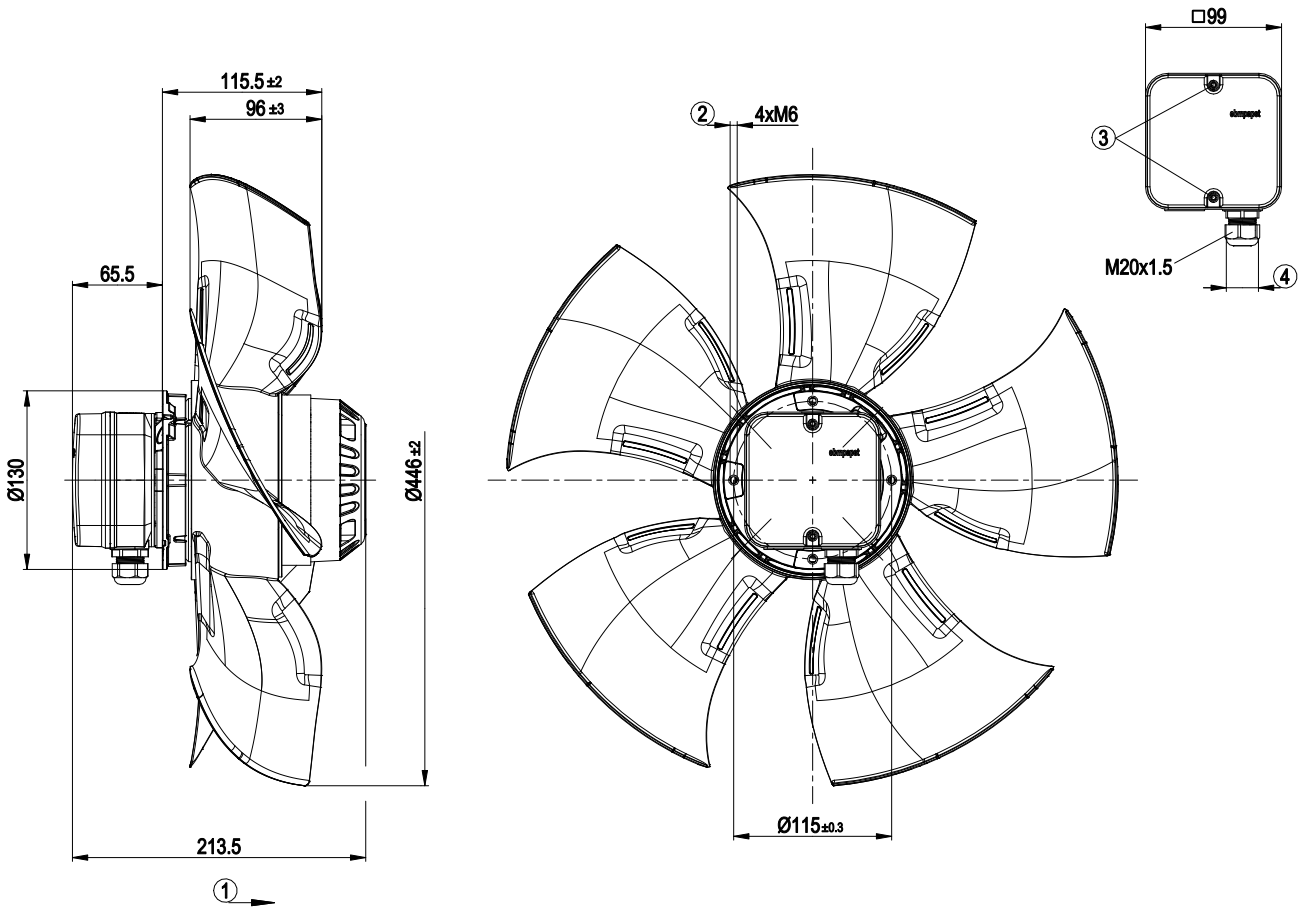

1	Direction of air flow "A"
2	Max. clearance for screw 10 mm
3	Tightening torque 0.8 ± 0.15 Nm
4	Cable diameter: min. 6 mm, max. 12 mm; tightening torque 2 ± 0.15 Nm



AC axial fan

sickle-shaped blades (S series)

Connection diagram

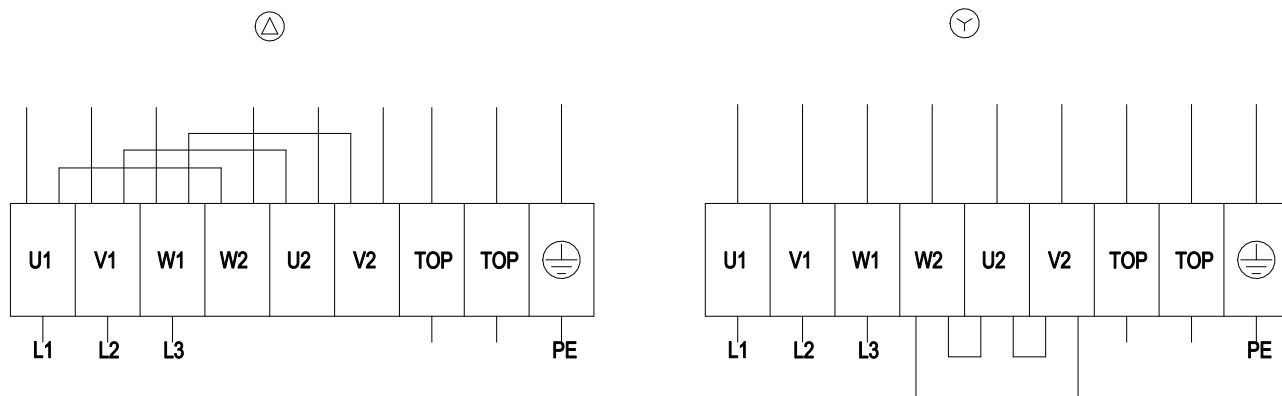

Δ	Delta connection	Y	Star connection	L1	= U1 = black
L2	= V1 = blue	L3	= W1 = brown	W2	yellow
U2	green	V2	white	TOP	2x gray
PE	green/yellow				



Curves: Air performance 50 Hz

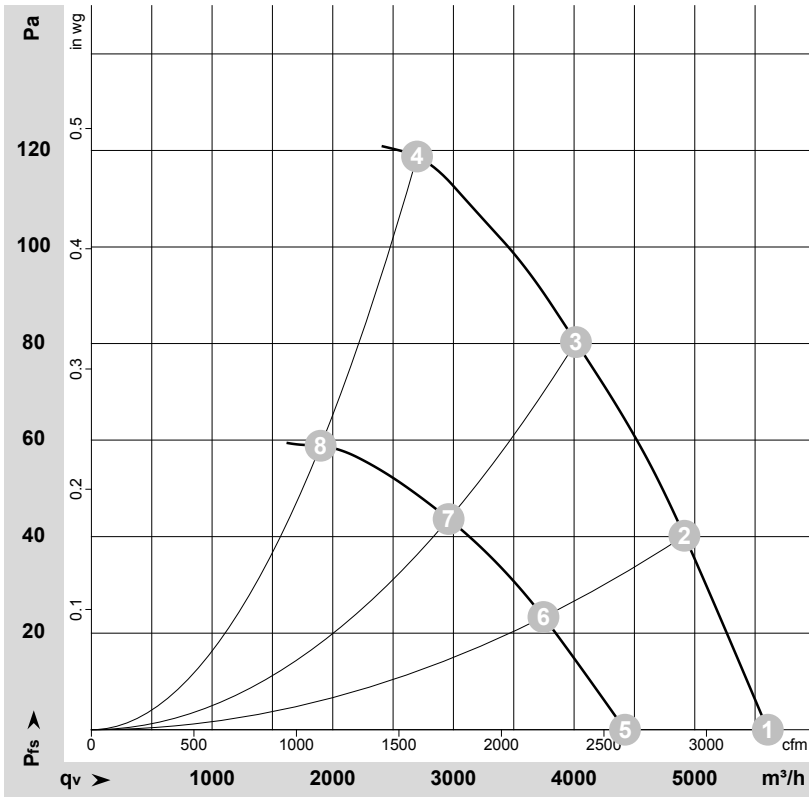

$\rho = 1.15 \text{ kg/m}^3 \pm 2 \%$

Measurement: LU-72632-1
Measurement: LU-72634-1

Air performance measured according to ISO 5801 installation category A. For detailed information on the measurement setup, contact ebm-papst. Intake sound level: Sound power level according to ISO 13347 / sound pressure level measured at 1 m distance from fan axis. The values given are valid under the specified measuring conditions and may vary due to conditions of installation. For deviations from the standard configuration, the parameters have to be checked on the installed unit.

Measured values

	Wired	U	f	n	P _e	I	qv	p _{fs}	qv	p _{fs}
		V	Hz	min ⁻¹	W	A	m ³ /h	Pa	CFM	inH2O
1	Δ	400	50	1350	231	0.49	5605	0	3300	0.00
2	Δ	400	50	1320	264	0.53	4915	40	2890	0.16
3	Δ	400	50	1295	293	0.56	4015	80	2365	0.32
4	Δ	400	50	1250	340	0.61	2700	120	1590	0.48
5	Y	400	50	1070	160	0.27	4420	0	2605	0.00
6	Y	400	50	1015	173	0.29	3745	23	2205	0.09
7	Y	400	50	960	183	0.31	2960	44	1740	0.18
8	Y	400	50	875	200	0.33	1900	59	1120	0.24

Wired = Wiring · U = Power supply · f = Frequency · n = Speed (rpm) · P_e = Power consumption · I = Current draw · qv = Air flow · p_{fs} = Pressure increase



Curves: Air performance 60 Hz

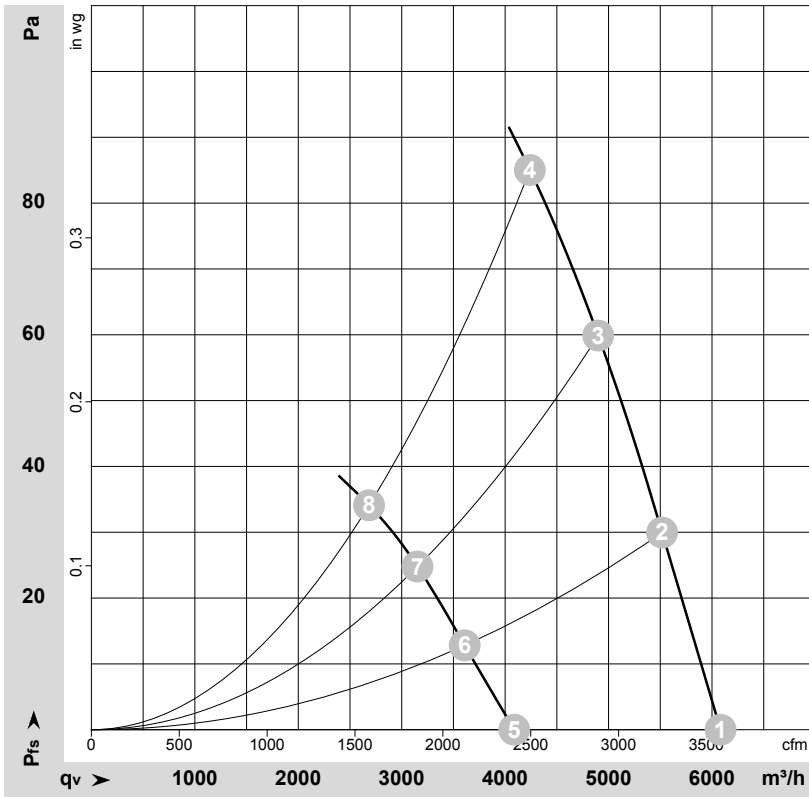

$\rho = 1.15 \text{ kg/m}^3 \pm 2 \%$

Measurement: LU-72642-1
Measurement: LU-72646-1

Air performance measured according to ISO 5801 installation category A. For detailed information on the measurement setup, contact ebm-papst. Intake sound level: Sound power level according to ISO 13347 / sound pressure level measured at 1 m distance from fan axis. The values given are valid under the specified measuring conditions and may vary due to conditions of installation. For deviations from the standard configuration, the parameters have to be checked on the installed unit.

Measured values

	Wired	U	f	n	P _e	I	qv	p _{fs}	qv	p _{fs}
		V	Hz	min ⁻¹	W	A	m ³ /h	Pa	CFM	inH2O
1	Δ	400	60	1455	334	0.57	6085	0	3580	0.00
2	Δ	400	60	1415	360	0.61	5520	30	3250	0.12
3	Δ	400	60	1380	384	0.64	4900	60	2885	0.24
4	Δ	400	60	1360	415	0.70	4240	85	2495	0.34
5	Y	400	60	990	187	0.31	4090	0	2405	0.00
6	Y	400	60	935	192	0.32	3610	13	2125	0.05
7	Y	400	60	895	197	0.33	3150	25	1855	0.10
8	Y	400	60	860	205	0.35	2685	34	1580	0.14

Wired = Wiring · U = Power supply · f = Frequency · n = Speed (rpm) · P_e = Power consumption · I = Current draw · qv = Air flow · p_{fs} = Pressure increase

