

A4D450-AO18-09 ebmpapst Datasheet

sales@fansco.com

www.fansco.com

Limited partnership · Headquarters Muldingen

Amtsgericht (court of registration) Stuttgart · HRA 590344

General partner Elektrobau Muldingen GmbH · Headquarters Muldingen

Amtsgericht (court of registration) Stuttgart · HRB 590142



Nominal data

Type	A4D450-AO18-09					
Motor	M4D094-HA					
Phase		3~	3~	3~	3~	3~
Nominal voltage	VAC	230	230	400	400	480
Wiring		Δ	Δ	Y	Y	Y
Frequency	Hz	50	60	50	60	60
Method of obtaining data		ml	ml	ml	ml	ml
Valid for approval/standard		CE	CE	CE	CE	CE
Speed (rpm)	min ⁻¹	1315	1420	1315	1420	1530
Power consumption	W	430	580	430	580	650
Current draw	A	1.40	1.73	0.81	1.0	0.95
Max. back pressure	Pa	115	85	115	85	100
Max. back pressure	inH ₂ O	0.46	0.34	0.46	0.34	0.4
Min. ambient temperature	°C	-40	-40	-40	-40	-40
Max. ambient temperature	°C	70	50	70	50	50

ml = Max. load · me = Max. efficiency · fa = Free air · cs = Customer specification · ce = Customer equipment

Subject to change

Data according to ErP Directive

		Actual	Req. 2015			
01 Overall efficiency η_{es}	%	31.2	31.2	09 Power consumption P_e	kW	0.41
02 Measurement category		A		09 Air flow q_v	m ³ /h	4510
03 Efficiency category		Static		09 Pressure increase p_{fs}	Pa	102
04 Efficiency grade N		40	40	10 Speed (rpm) n	min ⁻¹	1320
05 Variable speed drive		No		11 Specific ratio*		1.00

Data obtained at optimum efficiency level.

The ErP data is determined using a motor-impeller combination in a standardized measurement setup.

* Specific ratio = $1 + p_g / 100\,000\text{ Pa}$

LU-119179



Technical description

Weight	7.3 kg
Fan size	450 mm
Rotor surface	Painted black
Blade material	PP plastic
Number of blades	5
Airflow direction	"V"
Direction of rotation	Counterclockwise, viewed toward rotor
Degree of protection	IP54
Insulation class	"F"
Moisture (F) / Environmental (H) protection class	F5
Max. permitted ambient temp. for motor (transport/storage)	+ 80 °C
Min. permitted ambient temp. for motor (transport/storage)	- 40 °C
Installation position	Shaft horizontal or rotor on bottom; rotor on top on request
Condensation drainage holes	On rotor side
Mode	S1
Motor bearing	Ball bearing
Touch current according to IEC 60990 (measuring circuit Fig. 4, TN system)	<= 3.5 mA
Electrical hookup	Via terminal box
Motor protection	Thermal overload protector (TOP) with basic insulation
Protection class	I (with customer connection of protective earth)
Conformity with standards	EN 60034-1 (2010); CE

Product drawing

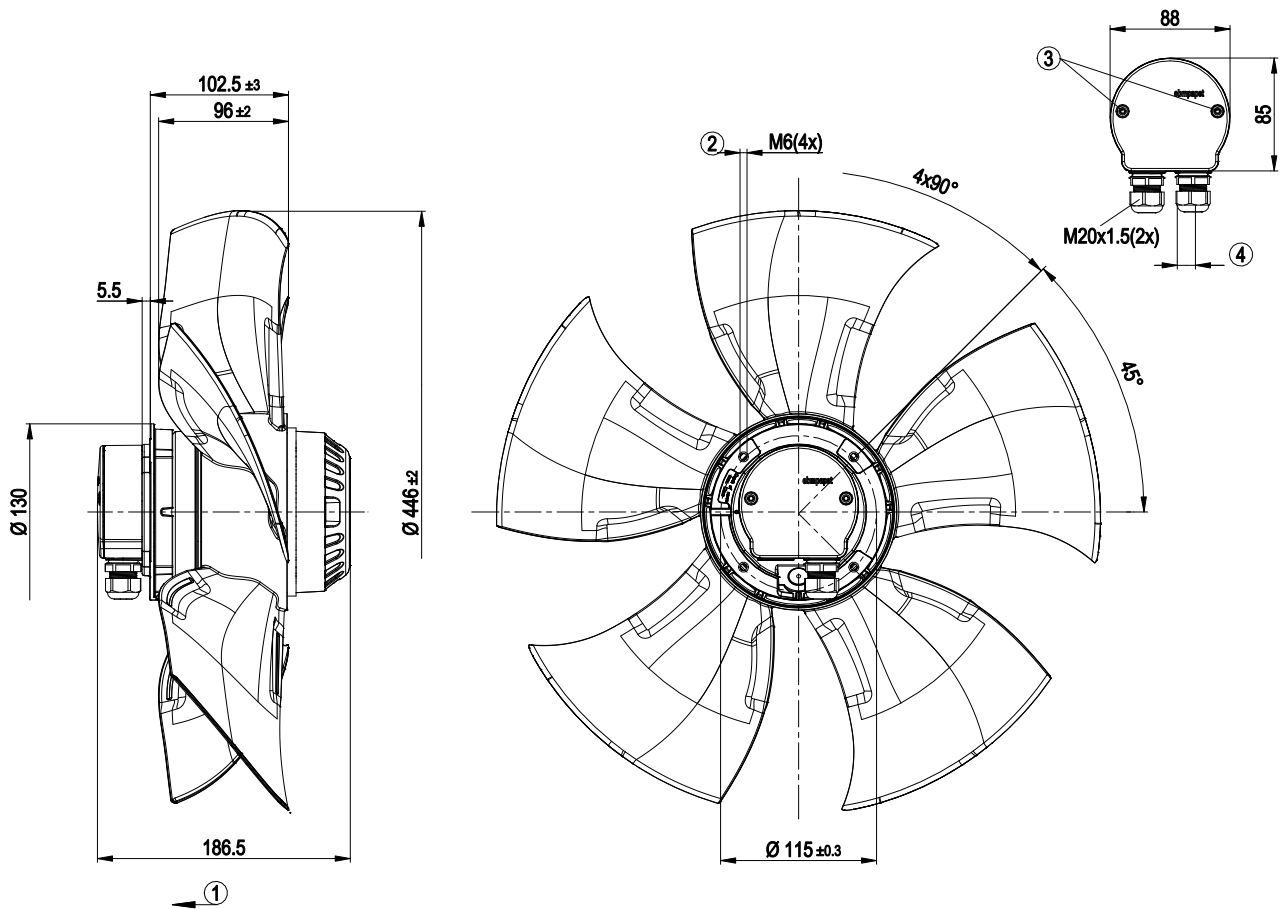

1	Direction of air flow "V"
2	Max. clearance for screw 12 mm
3	Tightening torque 1.0±0.15 Nm
4	Cable diameter: min. 6 mm, max. 12 mm; tightening torque 2±0.15 Nm

AC axial fan

sickle-shaped blades (S series)

Connection diagram



Δ	Delta connection	Y	Star connection	L1	= U1 = black
L2	= V1 = blue	L3	= W1 = brown	W2	yellow
U2	green	V2	white	TOP	2x gray
PE	green/yellow				



Curves: Air performance 50 Hz

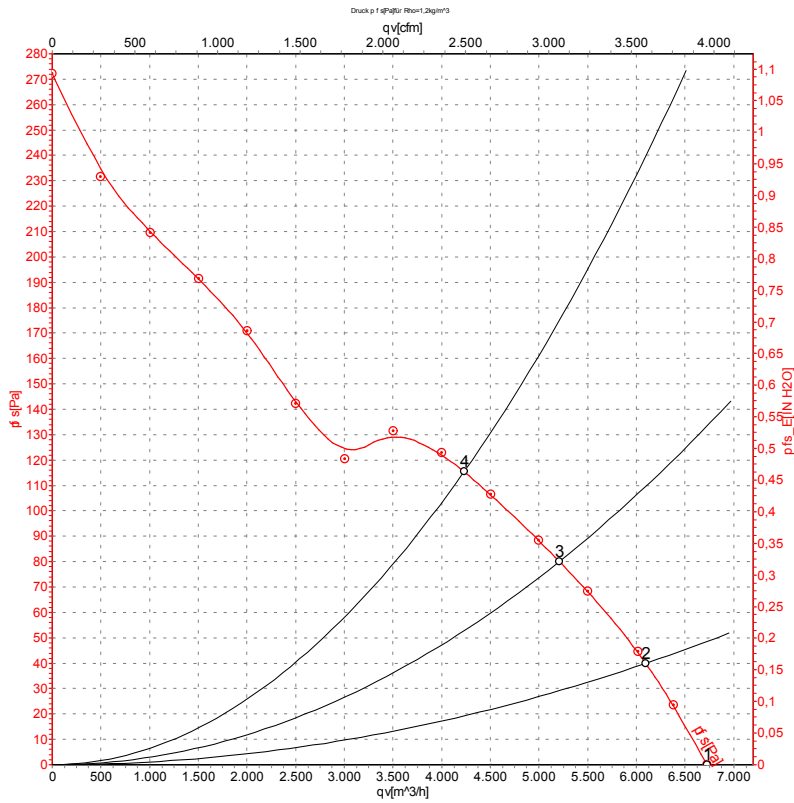

Measurement: LU-119179-1

Air performance measured according to ISO 5801 installation category A. For detailed information on the measurement setup, contact ebm-papst. Intake sound level: Sound power level according to ISO 13347 / sound pressure level measured at 1 m distance from fan axis. The values given are valid under the specified measuring conditions and may vary due to conditions of installation. For deviations from the standard configuration, the parameters have to be checked on the installed unit.

Measured values

	Wired	U	f	n	P _e	I	qv	p _{fs}	qv	p _{fs}
		V	Hz	min ⁻¹	W	A	m ³ /h	Pa	CFM	inH2O
1	Y	400	50	1360	346	0.69	6725	0	3960	0.00
2	Y	400	50	1345	374	0.73	6095	40	3590	0.16
3	Y	400	50	1330	399	0.76	5210	80	3065	0.32
4	Y	400	50	1315	430	0.81	4230	115	2490	0.46

Wired = Wiring · U = Power supply · f = Frequency · n = Speed (rpm) · P_e = Power consumption · I = Current draw · qv = Air flow · p_{fs} = Pressure increase



Curves: Air performance 60 Hz

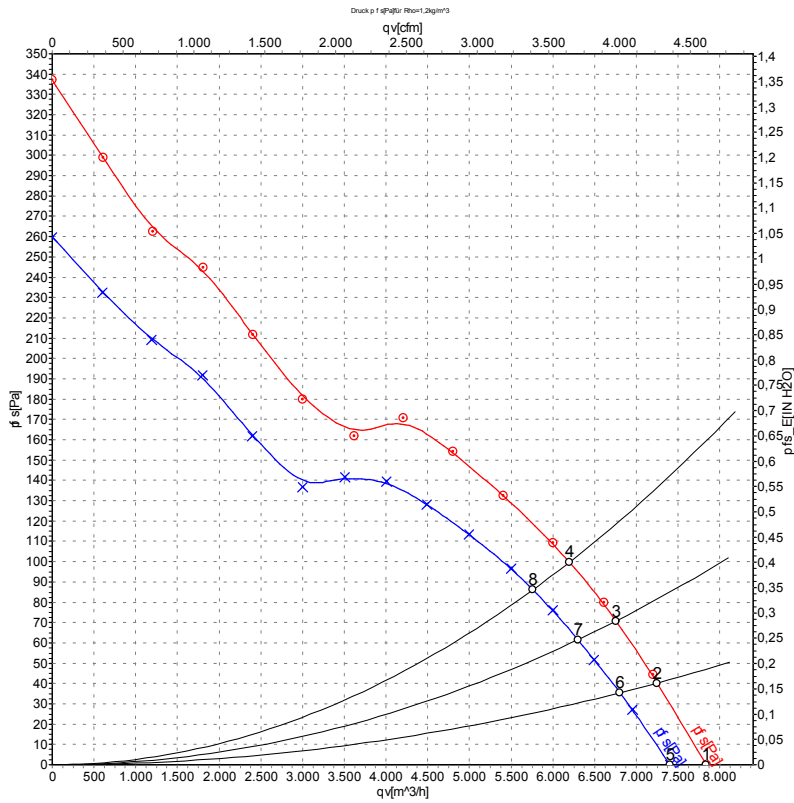

Measurement: LU-119186-1
Measurement: LU-119185-1

Air performance measured according to ISO 5801 installation category A. For detailed information on the measurement setup, contact ebmpapst. Intake sound level: Sound power level according to ISO 13347 / sound pressure level measured at 1 m distance from fan axis. The values given are valid under the specified measuring conditions and may vary due to conditions of installation. For deviations from the standard configuration, the parameters have to be checked on the installed unit.

Measured values

	Wired	U	f	n	P _e	I	qv	p _{fs}	qv	p _{fs}
		V	Hz	min ⁻¹	W	A	m ³ /h	Pa	CFM	inH2O
1	Y	480	60	1575	560	0.84	7835	0	4615	0.00
2	Y	480	60	1555	597	0.89	7245	40	4265	0.16
3	Y	480	60	1540	621	0.92	6755	70	3975	0.28
4	Y	480	60	1530	650	0.95	6200	100	3650	0.40
5	Y	400	60	1485	514	0.89	7405	0	4355	0.00
6	Y	400	60	1460	542	0.94	6805	36	4005	0.14
7	Y	400	60	1440	559	0.96	6300	62	3705	0.25
8	Y	400	60	1420	580	1.00	5760	85	3390	0.34

Wired = Wiring · U = Power supply · f = Frequency · n = Speed (rpm) · P_e = Power consumption · I = Current draw · qv = Air flow · p_{fs} = Pressure increase

